

# 60 GHz On-Chip Antenna Array with Efficiency Improvement Using 3D Microfabrication Technology

M. Zamith, J. Magalhães, P. Anacleto, P. M. Mendes  
Dept. of Industrial Electronics, University of Minho, Guimarães, Portugal

**Abstract**— The 55-65 GHz band has very interesting characteristics, such as allowing high-bandwidth communications and improved security (due to high absorption). From the antenna point of view, it also has the interesting feature of allowing the fabrication of very small antennas. Because they're so small, these antennas can be placed directly on-chip. However, silicon is a high loss material at such high frequencies. This paper proposes a solution to obtain one antenna array with improved efficiency. Instead of designing the antennas on top of silicon, 3D antennas are designed to lie above the silicon substrate.

**Keywords**—integrated antenna, on-chip antenna, antenna array, 60 GHz, MMID.

## I. INTRODUCTION

It's expected that systems at 55-65 GHz millimetre-wave band will change the way we experience our wireless communications at home [1]. The 60 GHz band promises new solutions from wireless sensors to short-range high-speed mobile data rate. However, they are still too expensive to become widely deployed. One possible solution aiming price reduction is system integration using CMOS technology, where the antenna may be considered for on-chip placement due to its small size. The solutions proposed in this band range from simpler designs [2] to more complex solutions [3], but the obtained efficiency still has room for improvement. From [4], and references mentioned in [4], on chip-antennas show efficiencies in the range of 50%, even when using artificial substrates for efficiency improvement, requiring extra area and complexity.

The solution for a significant improvement in the antenna efficiency is to find new integration methodologies, preferably suitable for CMOS integration, due to pricing reasons. Because of the great attenuation in this frequency band, it is desirable to have antennas with high gain, which may be achieved using an antenna array. In this paper we propose a new antenna integration methodology suitable for on-chip antenna-array integration with RFCMOS circuitry. The proposed solution was developed for antenna integration with the CMOS circuitry shown in [5]. Due to the availability of four on-chip oscillators, allowing four antenna inputs, this paper analyses the expected performance for such four-antenna array.

## II. SYSTEM DESIGN

The main concept is based on the use of 3D elements [6], allowing an antenna to float on top of the substrate.

### A. Integration Methodology

In this paper we propose an array with four antennas since the chip that will be used for future integration [5] has four on-chip oscillators and four RF inputs in the desired central frequency. This chip will allow the testing of the proposed integration methodology. Fig. 1 shows the proposed antenna integration solution.

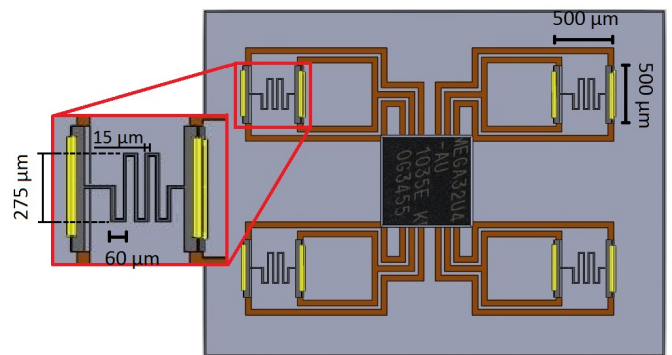

Fig. 1. Artistic view of the proposed integration methodology.

The microfabrication process of the three-dimensional structures starts with a clean silicon wafer. A 10 nm Tantalum layer that acts as the adhesion layer between the silicon wafer and the copper layer is then deposited by sputtering. A 200 nm of copper is now deposited, to act as a seed layer for the electroplating techniques. This is followed by a copper oxide layer (2 μm thick) deposition and patterning, through a lithography process (1). In the first electroplating process, a 2 μm layer of copper will form the support that attaches the three-dimensional structure to the wafer (2). This support is protected with the copper oxide layer previously deposited. The common self-folding process can now be started.

In the self-folding process another seed and adhesion layer are required for the following electroplating steps. These layers were deposited by sputtering (with the same thickness). A lithography process is performed at this stage to pattern the areas where the antenna faces will be deposited. A nickel electroplating process is then done. These nickel faces have a thickness of 5 μm (3). After the antenna faces deposition, another lithography step is done, and the last electroplating is performed to deposit (Tin) the hinges of the structures (4), with a thickness of 10 μm. The deposition process is done and the last step is the elimination of the seed, adhesion and the

copper oxide layers (5). Now the self-folding can occur. The structure is emerged in water, and heated up till the folding starts (6). After a few minutes the structures are completely folded (7) and the communication chip is integrated (8). Fig. 2 shows the artistic view of the integration methodology.

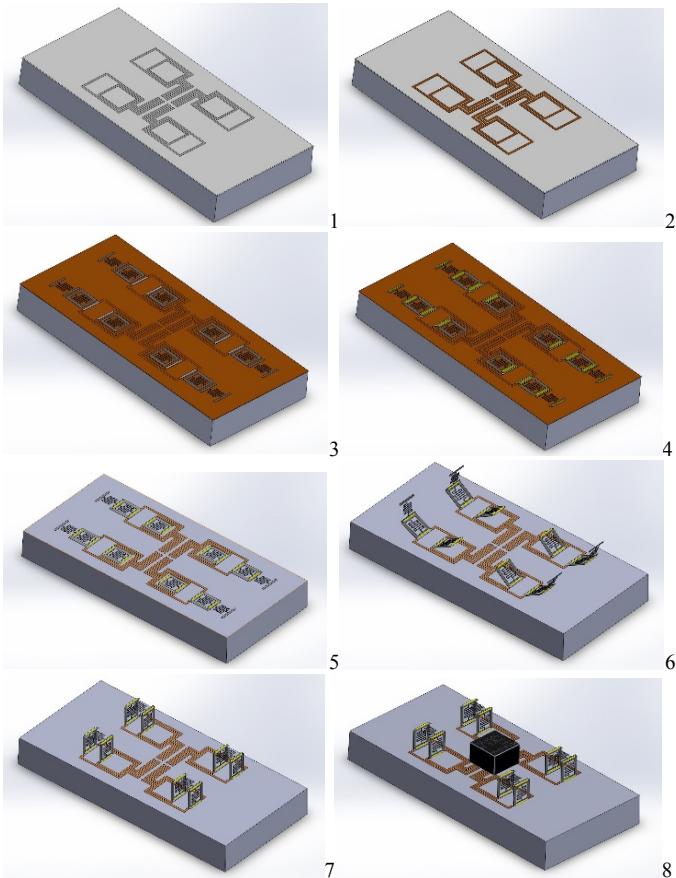

Fig. 2. Microfabrication process of the antenna array.

### B. Antenna Element

Fig. 3 shows the HFSS model of one antenna element, on top of a silicon die. Due to the chip oscillators' frequency, it was tuned to operate at 55 GHz central frequency.

The previous model was designed using the material properties available in [7]. The model was then fed using a lumped port to obtain the antenna element S11 and the array radiation pattern for different phase shifts between each antenna port.

## III. MMID FOR SURGICAL TOOLS

The main advantage of the integration methodology proposed in this paper (Fig. 2) is the possibility to obtain a very small microsystem with RF frontend and antenna fully integrated. In this way, this system is a good candidate for MMID (millimetre wave identification) applications where ultra-small MMID transponders are required [8].

### A. Surgical Tools

An issue that is not yet solved is the problem related with the need to control the tools used during a surgery. The solution adopted in many places to control the flow of surgical

tools inside a surgical room is manual counting. The main difficulty to implement MMID solution on surgical tools is the requirement of not changing, by any means, the shape of the surgical tools.

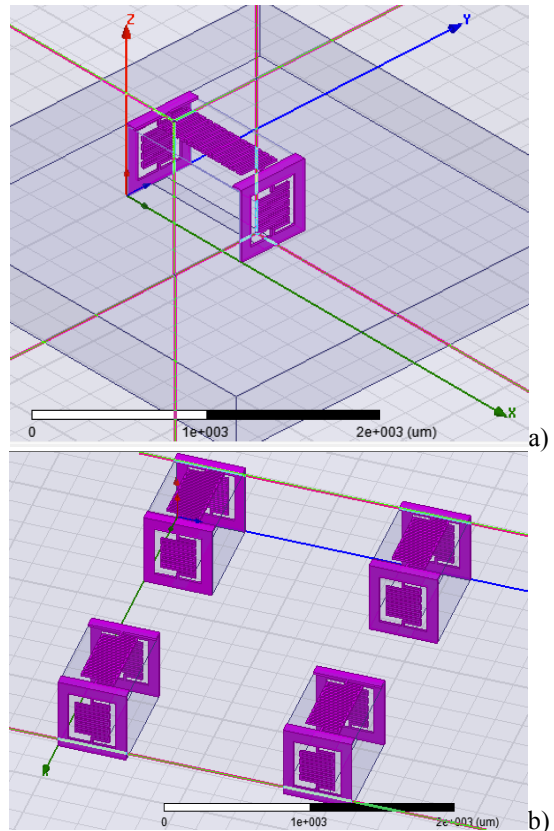

Fig. 3. Ansys HFSS model for: a) single antenna element; b) antenna array.

Another technical issue is due to the fact that surgical tools are mainly made of some kind of metal. This introduces some restrictions to antenna placement. However, the use of the 60 GHz band, since the wavelength is smaller than at lower frequencies, alleviates the antenna placement issue since, for the same physical distance between antenna and metallic tool, the electrical distance is larger. In this way, the antenna radiation pattern is less dependent on the surgical tool.

### B. Millimetre Wave Identification

As the RFID systems, the operation of a MMID requires a base station that will interrogate a MMID tag [9]. One key issue for the system operation is the system operating range. Since we are operating in the 60 GHz ISM band, the signal attenuation will be more severe than the systems operating in the low RF, UHF, MHz, or kHz bands. To compensate for such high attenuation, MMID systems may use antennas with very high gain in the interrogator stations, and, if possible, the MMID tag may also have an antenna array to increase the readout range.

Of course, increasing the gain will make the readout more sensitive to the surgical tools positioning. This way, the antenna gain at the MMID tag will always be a trade-off between range and sensitivity to tag position. To assess how severe the attenuation of a wireless link in the 60 GHz ISM

TABLE I. SIMULATED RADIATION PATTERN CONTROL USING DIFFERENT PHASE SHIFT FOR THE DIFFERENT ANTENNA ARRAY ELEMENTS.

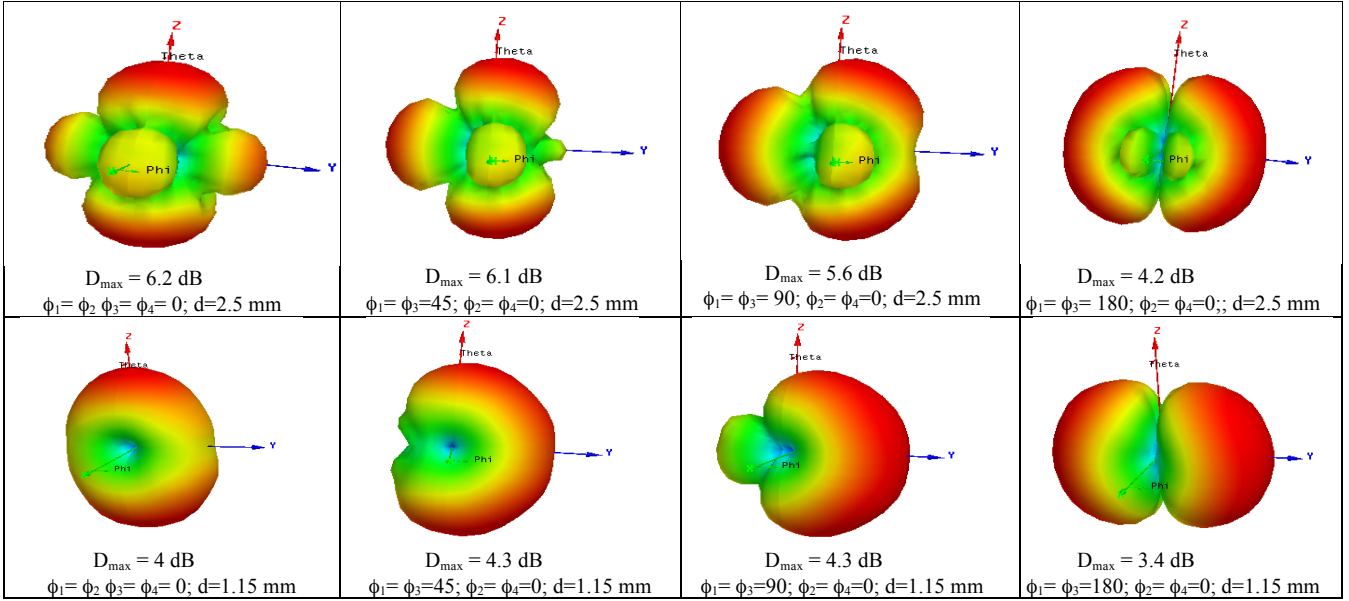

band may be, the two FC1003V/01 Series Converters, from Siversima [10], were used to explore the feasibility of a MMID solution inside a surgical room. Next section will show the measured results obtained.

#### IV. RESULTS AND DISCUSSION

This section will show a few results related with an antenna single element, the antenna array, and the wireless link at 60 GHz ISM band.

##### A. Antenna Element Properties

Using the antenna element model shown in Fig. 3, the return loss, antenna efficiency, and gain were predicted. Fig. 4 shows the return loss for an antenna single element.

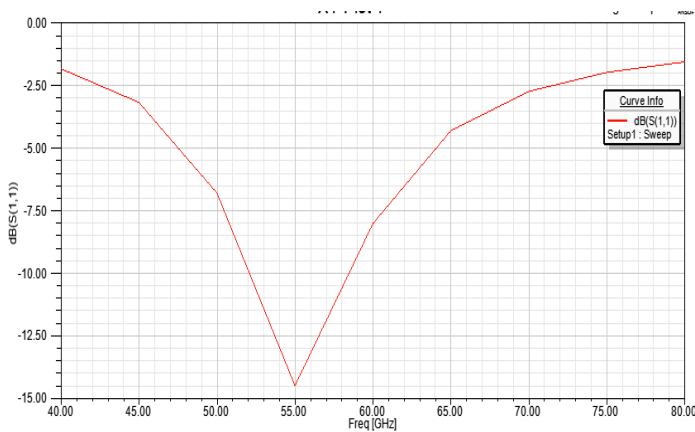

Fig. 4. Ansys HFSS model for the single antenna element.

##### B. Antenna Array Properties

Using the antenna array model from Fig. 3, the simulated efficiency was 55% and maximum gain was 0.6 dB. This is not a big improvement when compared with [4], but has an advantage since it does not require any special substrate design.

The radiation patterns results are shown table 1, and were obtained for two distances,  $d$ , between antennas. Table 1 was obtained with  $d = 1.15$  mm and  $d = 2.5$  mm. Since we have four antennas, the radiation pattern may be controlled changing the phase shifts at the input of each antenna element. The solution selected was for  $d = 1.15$  mm, since it allows the placement of the four antennas on top of the chip.

From table 1, and considering antenna efficiency around 55%, it's possible to observe a significant improvement in antenna gain compared to solutions from [4]. The herein proposed antenna array is not larger than the antenna in [4], when we consider also the artificial substrate.

##### C. Attenuation Expected in the MMID

To estimate the expected attenuation at 60 GHz ISM band, two FC1003V/01 Series Converters [10] were used to perform measurements on the received power when the transmit power was set to 15 dBm, and the carrier frequency was set to 60 GHz, with an IF I-signal at 3 GHz. IF Q-signal was not used. The used transceiver modules do not allow a direct measure of the received power, only at the IF frequency (1 – 5 GHz), but since all the transceiver settings are kept constant during measurements, the power measured at the IF frequency allows us to have an idea about the expected attenuation when using such frequencies.

To obtain data close to what will be obtained in a real scenario, the measurements were done inside the laboratory, without any particular attention to multipath, fading, or reflections.

With the two modules referred above, two different measurements were made: one to observe what happens with distance, and the other was made at a fixed distance but for different angles between transmitter and receiver.

Fig. 5 shows the plot when the distance was changed between 5 cm and 500 cm.

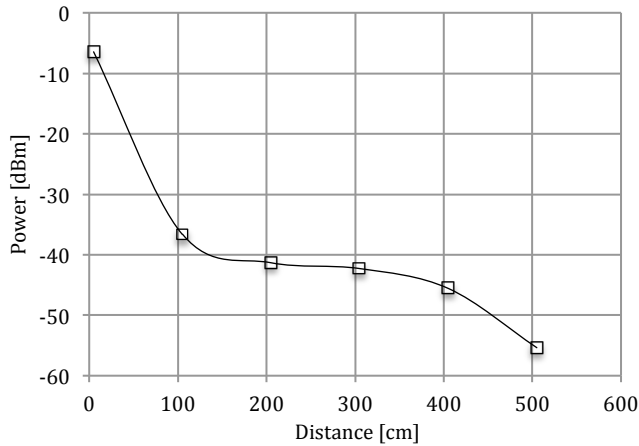

Fig. 5. Received power for different distances (first distance was set to 5 cm).

We can see a significant power drop, but the system was still operating, and we could even go for larger distances than those at which the wireless link was kept.

Fig. 6 shows the measured results when the systems were placed 4 m apart and the receiver was rotated (the radiators were operating without any antenna, being the radiation element the rectangular waveguide aperture).

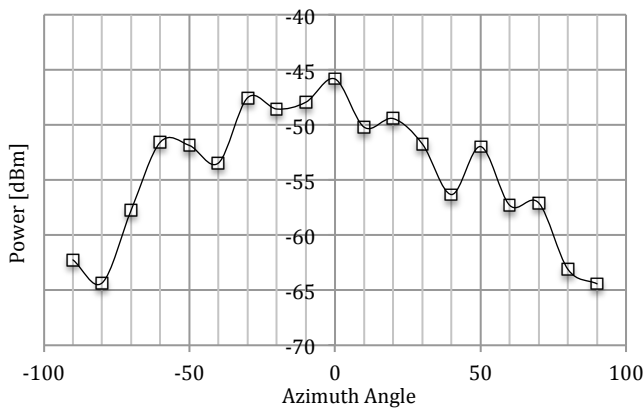

Fig. 6. Received power for different angles, at 4 m between modules.

The results obtained in Fig. 6 are also indicators that a MMID system at such frequencies, despite the attenuation suffered when the receiver is misaligned, are able to operate. And, for small degrees, performance is only slightly affected.

#### D. Antenna Array Measurement Setup

With all the previous measurements and simulations performed, the next goal will be the measurement of our proposed antenna array solution. To test the proposed antenna integration methodology, the setup shown in Fig. 7 was implemented.

The left transmitting side is comprised by a signal generator and frequency multiplier (minicircuits ZX90-2-24+), followed by the HXI frequency multiplier (HAFMV4-187) and

a horn antenna (Q-par QSH-SL-50-75-V-20). The right receiving side (DUT) is comprised by the silicon chip [5] with the 3D antennas mounted on it.

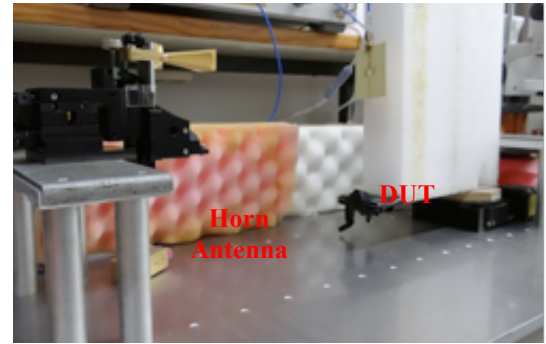

Fig. 7 Measurement setup to characterize the on-chip antenna array.

## V. CONCLUSIONS

In this work we propose the integration of 3D antennas on top of a silicon wafer. A solution was proposed towards the development of a fully integrated receiver operating in the 55–65 GHz millimetre-wave band, with improved efficiency. The proposed integration solution will allow the development of ultra-small MMID tags that will enable MMID in the 60 GHz ISM band. The attenuation results obtained from measurements at 60 GHz inside a room are also encouraging towards the feasibility of a MMID solution for surgical tools.

## ACKNOWLEDGMENT

This work was supported by Portuguese Foundation for Science and Technology: FCT-PTDC/EEI-TEL/2881/2012, Programa Operacional Temático Fatores de Competitividade (COMPETE) and Fundo Comunitário Europeu FEDER.

## REFERENCES

- [1] - Rangan, S.; Rappaport, T.S.; Erkip, E. "Millimeter-Wave Cellular Wireless Networks: Potentials and Challenges", Proceedings of the IEEE, On page(s): 366 - 385 Volume: 102, Issue: 3, March 2014
- [2] - Johnstone, J.C.; Frank, B.M.; Antar, Y.M.M. "Coupled Loops for High-Frequency Chip-to-Antenna Interconnection at 24 GHz", IEEE Trans. on Micr Theo. and Tech., pp. 1203 - 1211 Vol. 62, Issue: 5, May 2014
- [3] - Wonbin Hong; Kwang-Hyun Baek; Goudelev, A. "Grid Assembly-Free 60-GHz Antenna Module Embedded in FR-4 Transceiver Carrier Board", IEEE Trans. Ant. Prop., 1573 - 1580 Vol. 61, No 4, April 2013
- [4] - A. Barakat, A. Allam, H. Elsadek, "Small Size 60 GHz CMOS Antenna-on-Chip: Gain and Efficiency enhancement using asymmetric Artificial Magnetic Conductor," in 44th European Microwave Conference (EuMC), Rome, Italy, 5-10 October, 2014.
- [5] - Moroni, A.; Genesi, R.; Manstretta, D. "Analysis and Design of a 54 GHz Distributed "Hybrid" Wave Oscillator Array With Quadrature Outputs", Solid-State Circuits, IEEE Journal of, On page(s): 1158 - 1172 Volume: 49, Issue: 5, May 2014
- [6] - S. Gomes, J. Fernandes, P. Anacleto, E. Gultepe, D. Gracias, P. M. Mendes, "Ultra-Small Energy Harvesting Microsystem for Biomedical Applications," 44th EuMC, Rome, Italy, 5-10 October, 2014
- [7] - R. Daniels, J. Murdock, T. Rappaport and R. Heath "60 GHz wireless: Up close and personal", IEEE Microwave Mag., vol. 11, no. 7, pp.44 - 50 2010.
- [8] - Fonte, A.; Saponara, S.; Pinto, G.; Neri, B., "Feasibility study and on-chip antenna for fully integrated iRFID tag at 60 GHz in 65 nm CMOS SOI," RFID-Technologies and Applications (RFID-TA), 2011 IEEE International Conference on, vol., no., pp.457-462, 15-16 Sept. 2011.
- [9] - P. Pursula, T. Karttaavi, M. Kantanen, A. Lamminen, J. Holmberg, M. Lahdes, I. Marttila, A. Luukanen and T. V&auml;uam!;h&auml;uam!;-Heikkil&auml;uam!; "60-GHz millimeter-wave identification reader on 90-nm CMOS and LTCC", IEEE Trans. Microw. Theory Tech., vol. 59, no. 4, pp.1166-1173 2011.
- [10] - <http://www.siversima.com/products/millimeter-wave-converters/>.