

Mould redesign and analysis for the production of a micro-accelerometer

C.S. Silva*, P. Pereira, J.C. Viana, L.A. Rocha, A.J. Pontes,
Institute for Polymers and Composites /I3N, U. Minho, Guimarães, Portugal

(* *catiasilva@visitor.inl.int*)

ABSTRACT: In this paper we present an alternative fabrication method based on polymeric materials and technologies for three-axis thermal accelerometers. The device is composed by four microinjected parts forming an external structure responsible for the coupling and sealing of a polymeric membrane. The membrane contains and protects the heater and thermoresistors and is fabricated by microtechnologies. The fabrication process was successful although some issues were noticed in the mould during the microinjection process. Regarding the ejection side, a redesign was done to first assure the locking of the micro-parts on the movable side of the mould and second to improve the extraction of the parts avoiding its deformation. Overheating of the mould and polymer freezing on the injection nozzle were the main issues found on the injection side of the mould. Three different injection nozzle designs and two different fabrication materials were analyzed and simulated. The results show that an intermediate injection nozzle design using Ampcoloy 940® as construction material can improve the maintenance of the established temperature values for both mould and injection nozzle.

1 INTRODUCTION

Since always the production of products and its components has been reduced in size in order to be lighter and allow the incorporation of more functions in a smaller space (Maluf & Williams 2004; Ho et al. 1998).

Accelerometers are MEMS sensors with applications in important fields such as automotive, medical, consumer electronics among others (Yazdi et al. 1998). Accelerometers can work based on distinct transduction mechanisms such as piezoelectricity, piezoresistivity, capacitive sensing, resonant frequency shift and thermal sensing. This work will focus in thermal accelerometers because their transduction mechanism is simple and presents no proof mass avoiding complex and expensive fabrication processes and mechanical failure typical from other types of accelerometers (Maillyet et al. 2003; Garraud et al. 2011; Park et al. 2008).

Thermal accelerometers contain a hot bubble (gas or fluid), a heater and temperature sensors equally distant inside a sealed chamber. Once electrical current is applied to the system the heater temperature increases due to Joule effect. If the acceleration is zero the heat is equally distributed over the hot bubble being measured the same temperature value at

the equally distant temperature sensors while if acceleration is different from zero the hot bubble shifts by free convection and different temperatures are measured by the temperature sensors. This temperature difference can be correlated to the acceleration value (Leung et al. 1997; Luo et al. 2002).

This paper presents an alternative fabrication method for thermal accelerometers based on the combining of microinjection moulding and MEMS technology. The use of polymeric materials with low thermal conductivity can overcome the thermal losses reducing this way the power consumption typical from silicon based technologies while the diverse design possibilities that polymeric technologies allow can overcome the limited z-axis design (Garraud et al. 2011; Park 2008).

Microinjection moulding technology allows the production of complex, small and low-weight polymeric parts. Polymeric materials are known for their wide range of thermal, mechanical and electrical properties and can be low cost processed for large scales (Huang & Chiu 2005; Sahli et al. 2009). This recent technology emerged due to new market requirements for smaller, complex, efficient and low-cost components (Vlack 1989; Varadan et al. 2006). Micromoulding builds on the idea of transferring the high potential of conventional injection moulding

for efficient production and economic advantages in the fabrication of micro-systems (Giboz et al. 2009; Whiteside et al. 2003). This recent technology found applications in several areas such as medicine, optics, biotechnology, electronic among others (Piotter et al. 2002; Griffiths et al. 2007).

The success of microinjection moulding requires a strict control over materials, processing and moulds. The process can be simply described as a polymeric material that is melted and injected under pressure to a mould cavity where it cools down and acquires the desired shape. Although quite similar to the conventional injection moulding, size and accuracy demands are greater and so the process presents several challenges such as the high temperatures, pressures and velocities associated with small channel dimensions for smaller amounts of injected material. The new requirements made impossible to adapt the conventional equipment and therefore new specialized equipment was developed (Attia et al. 2009; Jianhong et al. 2002).

Materials for microinjection moulding are required some specifications such as good flow capacity to easily flow through the small channels and fill the cavities with low pressure and good structural to sustain the process demands and ensure an easy demoulding preserving the quality of the parts.

The design and manufacture of moulds for microinjection moulding is one of the main challenges of the process due to its reduced tolerances and precise details (Whynott et al. 2007). The concepts and methods for conventional moulding design must be adapted or changed to best address the microinjection moulding process (Jiangong 2002). There are several processing techniques regarding the geometry, surface quality and aspect ratio intended. These processing techniques include mechanical micro-machining such as micro-grinding, micro-cutting, micro-milling or micro-drilling; laser structuring; micro-electric discharges, electrochemical machining; LIGA processes (lithography, electroplating, moulding) among others (Heckele & Schomburg 2004; Piotter et al. 2002).

Typically, micro-cavities are produced by inserts which are mounted in the main body of the mould. This way one can use harder steel for the inserts which is the mould part most subjected to thermal and mechanical demands while the main body of the mould can be made with less but still hard steel. Hard steel mould inserts are easily fabricated from three-dimensional micro-structure by mechanical micro-machining. The mould for microinjection moulding must allow the complete filling of the cavity and the ejection of moulded parts with quality (Piotter et al. 2002; Attia et al. 2009; Heckele & Schomburg 2004).

The injection nozzle typically is designed to achieve the partition plan of the mould and therefore

minimize the path of molten polymer while removing the need of a runner system (Jianhing 2002).

Finally, main processing parameters for microinjection moulding are the molten polymer temperature, the mould temperature and the injection speed and injection pressure (Attia et al. 2009; Giboz et al. 2007). The quality of a part is not only a factor of processing parameter. A very important consideration is the design of the micro-parts which should consider several aspects such as the thermal expansion and shrinkage and rheology of the selected material and the demoulding step (Heckele & Schomburg 2004).

The following sections describe the design and material selection to fabricate a 3-axis thermal accelerometer. The fabrication process was optimized and some issues regarding the mould were noticed. New approaches to solve these issues were designed, simulated and compared to obtain the most suitable solution.

2 THREE-AXIS THERMAL ACCELEROMETER

2.1 Design

The proposed three-axis thermal accelerometer (see Fig. 1) comprises an external structure responsible for the mechanical support and sealing of the assembled device and a flexible membrane containing the heater and temperature sensors.

The external structure is composed by four polymeric micro-parts (two identical top parts and two identical central parts) to mechanically support and assembly the membranes while sealing the entire device from outside influences.

The membrane is a polymeric thin film containing the heater and temperature sensors for the device functioning. The membrane is divided in three main structures (two top and one central structure) all connected to each other and to a connector pad areas allowing external access for future characterization. The membrane is assembled as depicted in the following figure. The polymeric external parts couple the membrane assuring an equal distance between the membrane's structures while sealing and defining the cavity dimensions.

2.2 Material

The external supportive structure is made by polystyrene with the grade Polystyrol 143E. This material was chosen because it is easily processed by microinjection moulding technology sustaining the process demands and it presents properties suitable for the device performance.

Small channels and high flow speeds demand a material with a high melt flow index (greater than $20\text{cm}^3/10\text{min}$) to reduce shear stress.

Microinjection moulding demands tight dimensional tolerances and therefore the polymer should present good dimensional stability and low shrinkage (lower than 0.5 %) when cooling.

The device performance demands consists in sustaining outside temperature variations between -20 °C and 60 °C and an inside maximum temperature of 50 °C when the device is functioning. Low thermal conductivity is very important to assure few or no heat losses (bellow 0.2 W/m.K) and high bulk resistivity (greater than 15×10^{15} Ohm.cm) for anti-static properties.

The membrane is made of polyimide (PI-2611) to support the aluminum layer forming the heater and temperature sensors. The heater and active elements are implemented in the membrane by using microtechnologies. The polymeric membrane must be compatible with the demands of the processing techniques and the device operation. When operating, the thermal accelerometer can generate a temperature of 350 °C at the heater requiring a material capable of sustain such a temperature value and also presenting low thermal conductivity (bellow 0.2 W/m.K) in order to avoid heat losses and overheating the polymeric supportive structure. Aluminum is used for both heater and temperature sensors due to its high temperature coefficient of resistance and because the use of the same material for both structures simplifies the fabrication process.

The assembly consists in the coupling of the polystyrene micro-parts with the polyimide membrane containing the heater and temperature sensors. The assembly uses fast coupling and an adhesive material to seal the chamber. The initial tests used cyanoacrylate as adhesive.

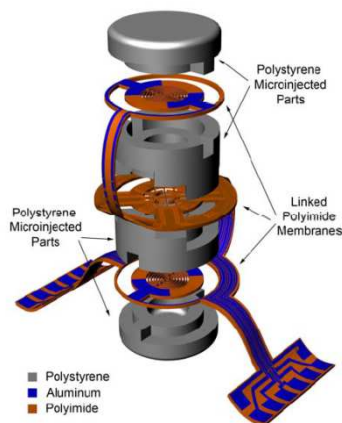

Figure 1. Three-axis thermal accelerometer drawing representation showing the main device parts and assembly configuration.

3 FABRICATION PROCESS

The full fabrication process includes three distinct phases: the microinjection moulding of the external supportive structure, the fabrication of the mem-

brane containing the heater and temperature sensors by using microtechnologies and the assembly.

The external supportive structure (see Fig. 2) was fabricated using a Boy 12A/M microinjection moulding machine. The main process parameters were optimized to: polymer melt temperature between 190-260 °C, mould temperature of 60 °C, an injection time of 2 s, an injection pressure of 110 bar and a total cycle time of 42 s.

Regarding the membrane fabrication process (see Fig. 3), polyimide is spin-coated and cured over a sacrificial layer of SiO₂ followed by the deposition and patterning of a composite of AlSiCu (90-5-5 %) forming the active elements. Next, a second layer of polyimide is spin-coated and cured to protect the entire structure. The connector pad areas (for external access) and defined regions of the polyimide are etched by RIE (Reactive Ion Etching) using an aluminum hard mask. Finally the polyimide is released from the substrate (see Fig. 4). The assembly of the 3-axis thermal accelerometer (see Fig. 5) is performed by fast coupling and by using cyanoacrylate adhesive to seal the polyimide membranes between the micro-parts.

During the fabrication process, microinjection moulding showed some issues related to the mould. Both injection and ejection side of the mould required an analysis and possible reformulation.

Regarding the injection side, the nozzle was designed to reach the partition plan of the mould. This constant contact between the injection nozzle and the mould made difficult to control the system temperature. Premature freezing of the molten polymer over the injection nozzle would occur stopping the moulding cycle. In addition, the long length of the injection nozzle leads to a drop of the injection pressure established by the microinjection moulding machine. A low injection pressure can cause low compression of the material and the microinjected parts become sensitive to deformations, bending and incomplete filling can occur by shrunken parts or voids.

The ejection of the microinjected parts also presented some difficulties. Micro-parts would either shrink over the ejector pins or get locked on the injection side of the mould requiring manual extraction.

4 MOULD REDESIGN AND ANALYSIS

4.1 Actual ejection system

The main structure of the mould was fabricated by using steel 1.1730. This material is easily machined and typically used for mould and tool structures due to its mechanical resistance. Inserts were fabricated by using steel 1.2311 due to its feasibility of machining and polishing and the high usage resistance to constant shock and compression.

The actual ejection system (see Fig. 6) has a central ejector pin that moves forward and detaches the runner system and the microinjected parts from the moulding cavities. Once detached, the runner system and the micro-parts are ejected by gravity.

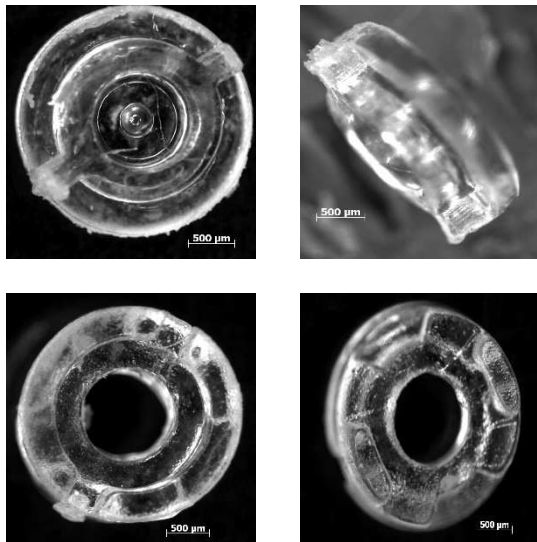

Figure 2. Microinjected components of the thermal accelerometer: (a) top part; (b) central part.

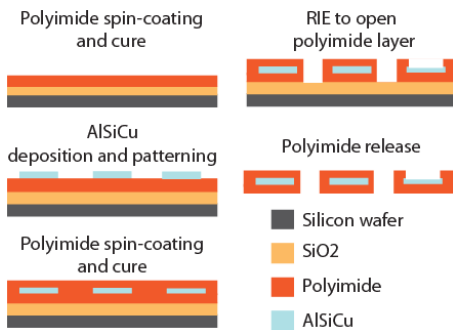

Figure 3. Fabrication process for the polyimide membranes incorporating the heater and temperature sensors.

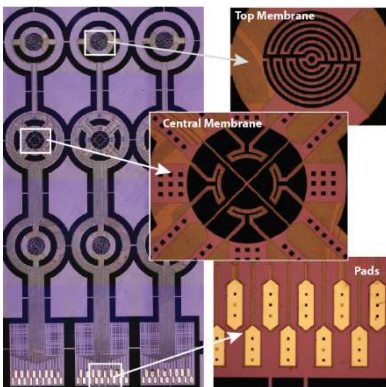

Figure 4. Fabricated membranes with heater and temperature sensors and detail of the membrane's structures.

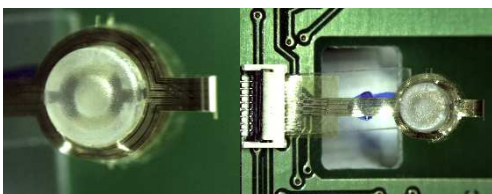

Figure 5. Assembled 3-axis thermal accelerometer mounted in the PCB (printed circuit board) for future characterization.



Figure 6. CAD drawing of the moulding cavities and the central ejector pin in detail.

4.2 Ejection system reformulation

The ejection system was altered addressing the top part and central part separately (see Fig. 7) while designed to avoid critical areas and to apply similar ejection forces enabling the parts to be ejected without significant deformations.

Regarding the top part, a central ejector with a diameter smaller than the moulding cavity was designed to move forward and detach the microinjected parts from the mould. The ejector for the central part is the whole moulding cavity due to its fragile design. The microinjected parts are ejected by gravity.

The ejectors move forward 16 mm to assure the complete extraction of the moulded parts.

A non-return pin was projected to lock the sprue on the movable side of the mould when it opens and once the ejection system is activated it moves forward releasing the sprue by gravity.

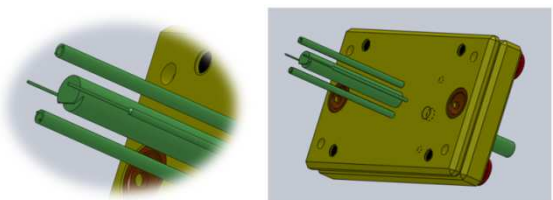

Figure 7. CAD design of the reformulated ejection system and detail.

4.3 Injection system

Three possible layouts for the injection system were designed and compared to achieve the most suitable solution. The analyzed solutions include the use of the standard injection nozzle of the microinjection moulding machine, the long nozzle initially fabricated and an intermediate nozzle (size ranging between the standard nozzle and the long nozzle).

Besides the new layouts, two materials were analyzed for the injection nozzle. The steel 2343 is typically used for the fabrication of injection nozzles and Ampcoloy 940 ® which is a copper alloy known for its thermal conductivity.

Ampcoloy 940 ® is an alternative solution to the use of resistances ensuring the temperature gradient along the injection nozzle. This material is a patented alloy class three without beryllium commonly used for applications requiring electrical and thermal conductivity as well as mechanical hardness and strength.

4.4 Actual injection nozzle

The fabricated injection nozzle (see Fig. 8) was designed to inject directly into the partition plan (see Fig. 9) avoiding the need of a sprue and with a variable diameter cross section of 3 mm at the screw and 1 mm at the injection nozzle edge. The long length of the injection nozzle requires a resistance in the middle to maintain the temperature established by the microinjection moulding machine.

The feeding system was dimensioned with 3 ° inclination angle while moulding areas present none. The moulding areas were over dimensioned 0.45 % in order to consider the polymer shrinkage.



Figure 8. Machined injection nozzle in steel 2343.

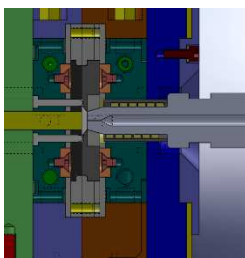

Figure 9. CAD detail of the long nozzle reaching the partition plan.

4.5 Standard nozzle

The standard nozzle (see Fig. 10) is the microinjection moulding machine injection nozzle. The smaller length ensures the heating by the microinjection machine while avoid the need of an extra resistance. The small size also maintains the injection pressure established by the machine. The contact with the mould is much smaller and therefore the temperature fluctuations are reduced. Alterations of the mould for this nozzle include an injection bushing connecting the standard nozzle to the partition plan assuring the filling of the cavity with molten polymer during the injection phase.

A metal ring was inserted in the mould to avoid movements from the sprue and runner system which can happen due to the reflux of pressure that is generated in the opposite direction of the injection pressure (see Fig. 11).

A new sprue was designed with a large length and a non-uniform diameter with an inclination angle of 3°. A non-return pin was projected to lock the moulded parts in the movable side of the mould when it opens. The runner system was kept the same (see Fig. 10).



Figure 10. Standard nozzle on the left; sprue and runner system on the right.

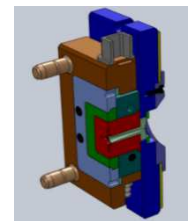

Figure 11. Detail of the injection part of the mould (CAD drawing).

4.6 Intermediate nozzle

The intermediate nozzle (see Fig. 12) guarantees no drops of the injection pressure while avoiding the use of a large sprue. The size allows it to be entirely heated by the microinjection moulding machine avoiding the use of additional resistances.

The sprue design is smaller when compared to the standard nozzle sprue and it was projected with the same principles and considerations for the dimensions and inclination angle (see Fig.12).

Two metal blocks give shape to the sprue while connecting the injection nozzle to the partition plan (see Fig. 13). One of the blocks shapes the moulding zone while the other block is in direct contact with the intermediate nozzle.

The block in contact with the injection nozzle is made of an isolating material in order to avoid temperature fluctuations. The selected isolating material was Celazone PBI due to its low thermal conductivity (0,4 W/K.m); capacity to operate at the service temperatures of molten polymers (sustains temperatures up to 310 °C); mechanical resistance to support the typical pressure and deformation of the moulding cycles (42 MPa); and a low coefficient of thermal expansion preventing volume and shape changes which can occur due to the constant contact with the nozzle (25×10^{-6} m/m.K). This material can be easily machined at low cost.

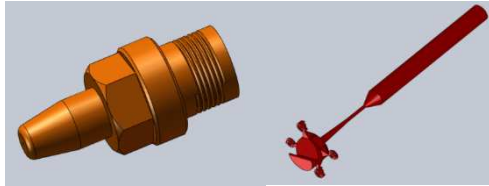

Figure 12. Intermediate nozzle on the left; sprue and runner system on the right.

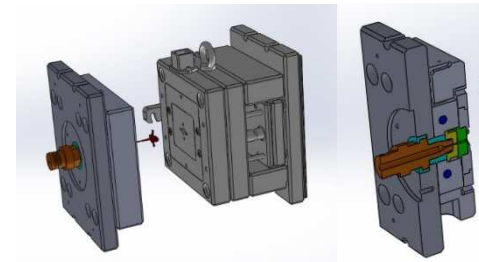

Figure 13. CAD drawing of the complete mould and detail of injection side.

5 SIMULATION ANALYSIS

The simulations were performed by using Ansys software. Steady-state thermal analysis enables the calculation of the effects of steady-state loads on a system or component. In this case we used steady-state thermal analysis to determine the temperature at the mould and at the injection nozzle. The simulations used the isotropic material properties meaning that the thermal properties of the materials in study are uniform in every direction.

Six simulations were done to evaluate and compare the three injection nozzle designs and the two materials.

The only data necessary to perform these simulations is the isotropic thermal conductivity of each material and the boundary conditions (see Table 1).

The simulation requires that every part of the models in study to be considered as a solid element. This includes the refrigeration system (water channels), air and molten polymer.

The mesh was generated with an element size of 3mm for the circular components and 5mm for the remaining mould structures.

Table 1. Material properties and boundary conditions.

Material	Thermal Conductivity	Temperature
	W/m.K	°C
Water	0.58	60
Air	0.0271 W/m.°C	Unknown
Steel 2343	23	260 (screw)
Ampcoloy 940 ®	208	260 (screw)
Steel 1.2311	39.6	Unknown
Steel 1.7310	50	Unknown
Polymer	0.15	260
Celazone PBI	0.4	Unknown

5.1 Long nozzle simulation

The long nozzle has two heating systems, the microinjection moulding machine and an extra resistance to induce a more homogeneous heating along the length of the nozzle. The simulation for the nozzle construction material steel 2343 gave a low temperature (200 °C) at the edge of the nozzle (see Fig. 14) which can lead to a premature freezing of the molten polymer. This result shows why the microinjection process was constantly being stopped to heat up the injection nozzle and required manual removing of frozen material from the injection nozzle.

The use of a thermal conductive material such as Ampcoloy 940 ® distributes more homogeneously the temperature.

The minimum temperature obtained for the long nozzle is 240 °C which should be enough to prevent material freezing (see Fig. 15).

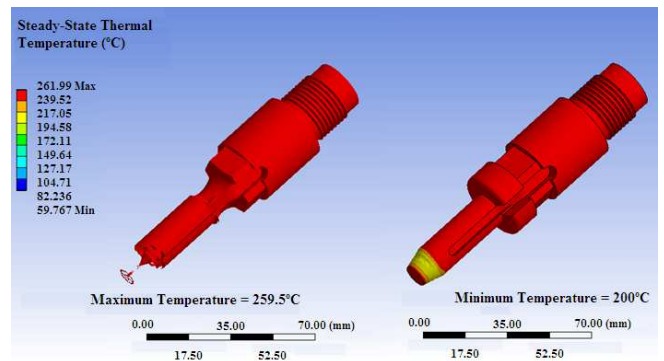

Figure 14. Long nozzle temperature variation (steel 2343).

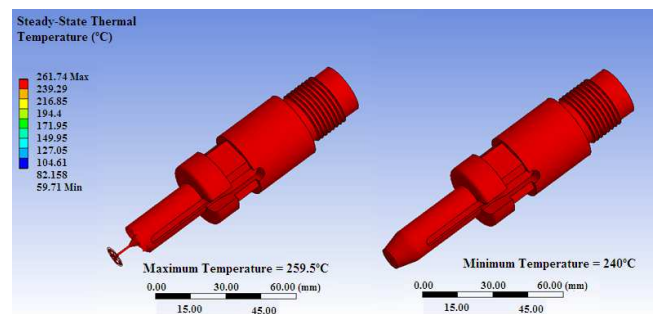

Figure 15. Long nozzle temperature variation (Ampcoloy 940®).

Regarding the mould, the cooling system (water channels) temperature should be 60 °C. When using steel 2343 for the long nozzle the minimum temperature is 61 °C while the maximum temperature value is 90 °C at the moulding areas (see Fig. 16).

When switching the injection nozzle material to Ampcoloy 940 ® the minimum mould temperature value is 62 °C while the maximum mould temperature is 95 °C (see Fig. 17). This temperature difference is related to the use of a more conductive material and the constant contact with the mould.

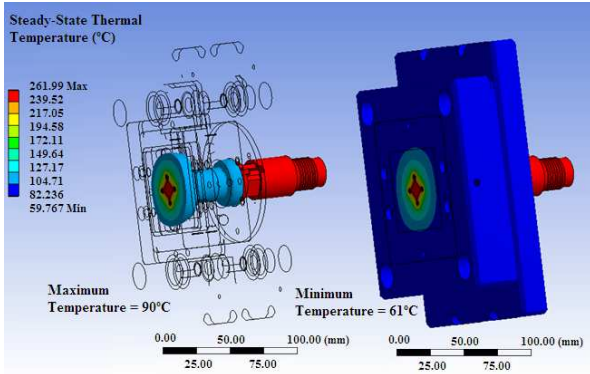

Figure 16. Long nozzle temperature variation for the mould (steel 2343).

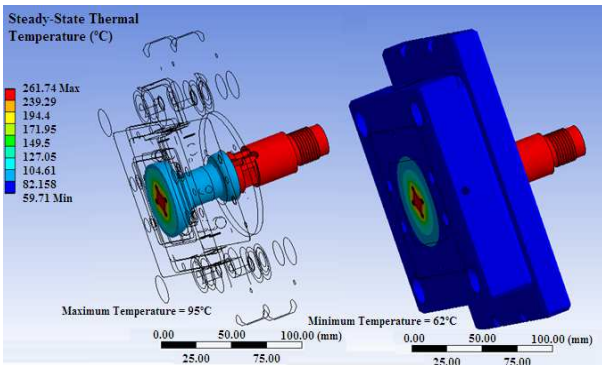

Figure 17. Long nozzle temperature variation for the mould (Ampcoloy 940®).

5.2 Standard nozzle simulation

The standard nozzle is only heated at the screw by the microinjection moulding machine and by the molten polymer flowing through the feeding channel.

The simulation with steel 2343 show a great temperature difference (nearly 40 °C) which could lead to premature freezing of the material (see Fig. 18). The use of Ampcoloy 940® lowers the temperature difference (nearly 20 °C) along the injection nozzle (see Fig. 19).

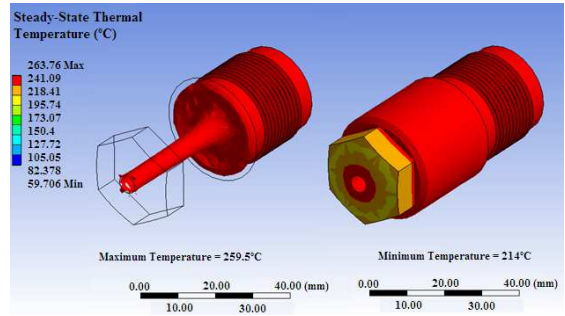

Figure 18. Standard nozzle temperature variation (steel 2343).

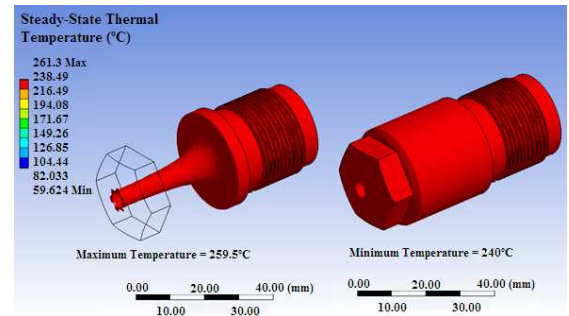

Figure 19. Standard nozzle temperature variation (Ampcoloy 940®).

The mould temperature variation is the same for both injection nozzle construction materials (see Fig. 20-21). The minimum temperature value is 66 °C while the maximum value is 100 °C. This can be related to the fact that the standard nozzle has a smaller contact with the mould than the long nozzle interfering less with the mould temperature.

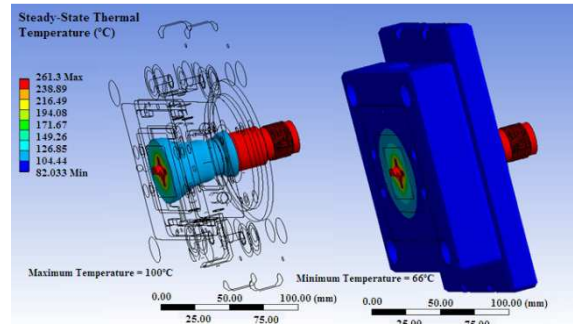

Figure 20. Standard nozzle temperature variation for the mould (steel 2343).

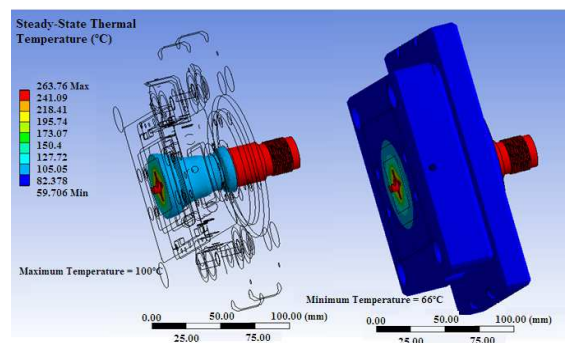

Figure 21. Standard nozzle temperature variation for the mould (steel 2343).

5.3 Intermediate nozzle simulation

The intermediate nozzle is also only heated by the microinjection moulding machine and by the molten polymer. The results (see Fig. 22) clearly show that when using Ampcoloy 940® the entire injection nozzle is at 258 °C which is nearly the molten polymer temperature (260 °C). This new design approach for the injection nozzle shows that even when using steel 2343 the minimum temperature is 250 °C which is already higher than the remaining injection nozzle designs (see Fig. 22).

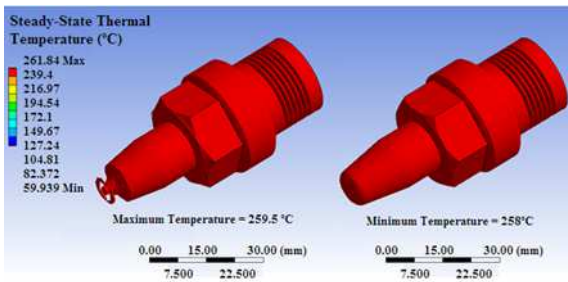

Figure 22. Intermediate nozzle temperature variation (Ampcoloy 940®).

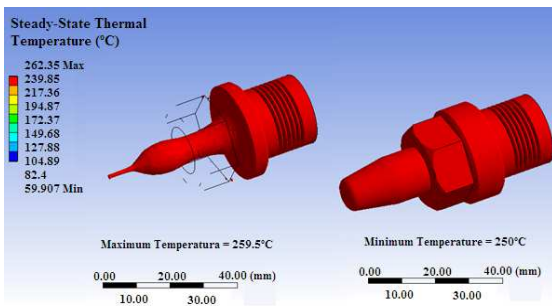

Figure 23. Intermediate nozzle temperature variation (steel 2343).

The maximum mould temperature is 90 °C at the moulding zones and the minimum temperature is 62°C which is nearly the initially established temperature for the mould (60 °C) (see Fig. 24-25).

The use of different nozzle construction materials causes no difference over the mould temperature. This is related to the use of the isolating block made of Celazone PBI which avoids temperature fluctuations between the injection nozzle and the mould.

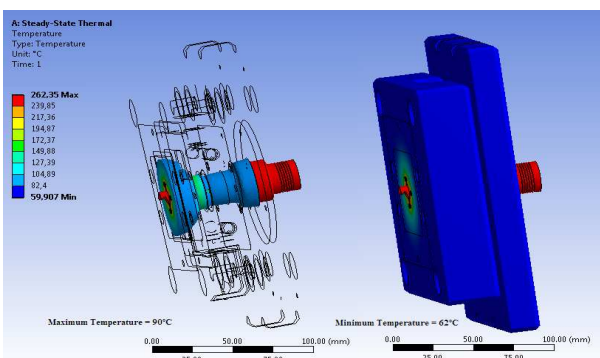

Figure 24. Intermediate nozzle temperature variation for the mould (steel 2343).

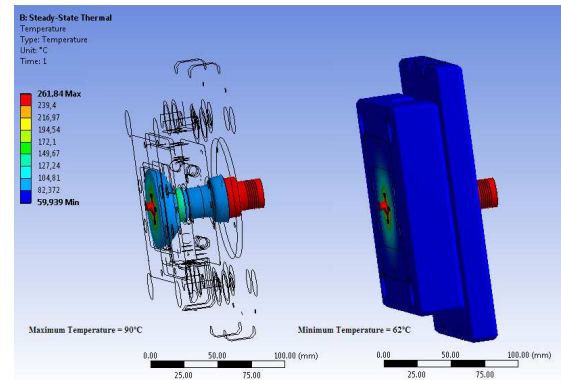

Figure 25. Intermediate nozzle temperature variation for the mould (Ampcoloy 940®).

CONCLUSIONS

The actual mould showed several issues regarding the ejection and injection systems. Regarding the ejection system the most suitable solution while preserving the actual system is to fabricate smaller extractors for the top parts and a non-return pin on the central ejector to lock the moulded parts and eject them by gravity when the ejection system is activated.

Concerning the injection side of the mould, three hypothesis were analyzed including the actual long nozzle, the standard nozzle of the microinjection moulding machine and an intermediate nozzle with the size ranging between the long and the standard nozzles. All changes in the mould were done while attempting to preserve the mould main structure.

Several simulations were performed to analyze the injection step. The results indicate that the most suitable solution is the intermediate nozzle design with Ampcoloy 940® as construction material. The use of an isolating block was only possible to integrate for the intermediate nozzle solution due to matters of space and reutilization of the existing mould plates. This solution improves the maintenance of the established temperature values for the mould and injection nozzle and the use of an intermediate nozzle assures the injection pressure value established by the microinjection moulding machine.

REFERENCES

- Attia, U.M. et al. 2009. Micro-injection moulding of polymer microfluidic devices. *Microfluid Nanofluid* 7:1–28.
- Garraud, A. et al. 2011. Frequency response analysis of an accelerometer based on thermal convection. *Journal of Micromechanics and Microengineering* 21: 035017
- Giboz, J. et al. 2007. Microinjection molding of thermoplastic polymers: a review. *Journal of Micromechanics and Microengineering* 17: R96–R109.
- Giboz, J. et al. 2009. Microinjection molding of thermoplastic polymers: morphological comparison with conventional injection molding. *Journal of Micromechanics and Microengineering* 19: 025023 (12p).

- Griffiths, C.A. et al. 2007. The effects of tool surface quality in micro-injection moulding. *Journal of Materials processing Technology* 189: 418–427.
- Heckele, M. & Schomburg, W.K. 2004. Review on micro moulding of thermoplastic polymers. *Journal of Micromechanics and Microengineering* 14: R1–R14.
- Ho, C.-M. & Tai, Y.-C. 1998. Micro-electro-mechanical-systems (MEMS) and fluid flows. *Ann. Rev. Fluid. Mech.*, 30: 579–612.
- Huang, C.K. & Chiu, S. W. 2005. Formability and Accuracy of Micropolymer Compound with Added Nanomaterials in Microinjection Molding. *Journal of Applied Polymer Science* 98: 1865-1874.
- Jianhong, Z. et al. 2002. Development of Mould Design Technologies and Process Parameter Studies in Micro Moulding Process. *Singapore Institute of Manufacturing Technology*.
- Leung, A. M. et al. 1997. *Micromachined accelerometer with no proof mass*, IEEE 899-902.
- Luo, X. B. et al. 2002. Thermal optimization on micromachined convective accelerometer. *Heat and Mass Transfer* 38: 705-712, Springer Verlag.
- Maily, F. et al. 2003. Micromachined thermal accelerometer. *Sensors and Actuators A* 103: 359-363.
- Maluf, N. & Williams, K. 2004. *An Introduction to Microelectrical Systems Engineering*, Artech House, Inc, ISBN 1-58053-590-9.
- Park, U. et al. 2008. *Development of A Complete Dual-axis Micromachined Convective Accelerometer with High Sensitivity*, IEEE SENSORS Conference.
- Piotter, V. et al. 2002. *Microinjection Moulding of Medical Device Components*, Business Briefing-Medical Device Manufacturing and Technology, S: 63-66.
- Sahli, M. et al. 2009. Quality assessment of polymer replication by hot embossing and micro-injection moulding processes using scanning mechanical microscopy. *Journal of Materials Processing Technology* 209: 5851-5861.
- Van Vlack, L. H. 1989. *Elements of Materials Science and Engineering, 6th Edition*, Person Education Inc.
- Varadan, V. K. et al. 2006. *Smart Material Systems and MEMS: Design and Development Methodologies*, John Wiley and sons Ltd.
- Whiteside, B.R. et al. 2003. Micro-moulding process Characteristics and Product properties. *Plastics, rubber and composites*. 32: 231-239.
- Whynott, J. et al. 2007. *Micromolding: A Cost-Effective Alternative to Micromachining*, MicroManufacturing Conference, Illinois, TP07PUB141.
- Yazdi, N. et al. 1998. *Micromachined Inertial Sensors*, Proceedings of the IEEE, 86: 1640-1659.