

---

## Conservation of cultural heritage buildings: Methodology and application to case studies

P.B. Lourenço

University of Minho, ISISE, Department of Civil Engineering, Portugal, e-mail: pbl@civil.uminho.pt,  
web: <http://www.civil.uminho.pt/masonry>, <http://www.isise.net>.

### RESUMEN

Las sociedades modernas entienden su patrimonio cultural como un hito de cultura y diversidad. Sólo durante las últimas décadas la idea de que edificios antiguos podrían ser conservados y reutilizados se ha convertido en atractiva. Sin embargo, una gran parte de este patrimonio es afectado por problemas estructurales lo cual amenaza la seguridad de los edificios y personas. Los desarrollos en el área de inspección, ensayos no destructivos, seguimiento y análisis estructural de construcciones históricas, bien como recientes normas para reutilización y conservación, permiten medidas correctivas más seguras, económicas y adecuadas. El artículo aborda las metodologías adoptadas, en diferentes casos de estudio así como presentes desafíos. En particular, intervenciones recientes en casos de estudio en Portugal (Catedral de Porto y Seminario de Braga) son analizadas con detalle.

**Palabras clave:** Edificios de patrimonio cultural; Conservación y rehabilitación; Terremotos e ingeniería sísmica; Casos de estudio.

### ABSTRACT

Modern societies understand built cultural heritage as a landmark of culture and diversity. Only during the last decades the idea that ancient buildings could be conserved and reused became appealing. Still, a large part of this heritage is affected by structural problems which menace the safety of buildings and people. The developments in the areas of inspection, non-destructive testing, monitoring and structural analysis of historical constructions, together with recent guidelines for reuse and conservation, allow for safer, economical and more adequate remedial measures. The paper addresses the issues of the methodology to adopt, of different cases studies and of present challenges. In particular, recent interventions in Portuguese cases studies (the Cathedral of Porto and a theological school in Braga) are analyzed in detail.

**Keywords:** Cultural heritage buildings; Conservation and rehabilitation; Earthquakes and seismic engineering; Case studies.

## 1. INTRODUCTION

The importance of ancient buildings has been for long exclusively attributed to their use, meaning that successive changes were made to fulfill their new function. At such times, lack of use would condemn the building to a ruin and, often, re-use of the stones elsewhere. Presently, modern societies understand built cultural heritage as a landmark of culture and diversity, which should last forever, being the task of the current generation to deliver the heritage in good shape for the generations to come. This act of culture poses high demands to engineers because deterioration is intrinsic to life (as an example the expected life of a modern building is fifty years).

Only during the last decades the idea that old and ancient buildings could be conserved and reused became appealing for the market. The present policy is not only to preserve but also to make buildings and the whole historic part of the cities alive, functioning and appealing to the inhabitants and to the tourists. It is the unique atmosphere of narrow streets and historic squares that provides a meaning to the cultural heritage of city centers, which must be the everyday reality for the local population.

Due to the effects of aggressive environment (earthquakes, soil settlements, traffic vibrations, air pollution, microclimate, etc.) and to the fact that many old buildings and historic centers were not subjected to maintenance, now a large part of this heritage is affected by structural problems which menace the safety of buildings and people. European countries have developed throughout the years a valuable experience and knowledge in the field of conservation, e.g. Croci (1998) or Theodossopoulos (2012). In recent years, large investments have been concentrated in this field, leading to impressive developments in the areas of inspection and non-destructive testing, e.g. McCann and Forde (2001), monitoring, e.g. Farrar, C.R. et al. (2004) and structural analysis of historical constructions, e.g. Lourenço (2002). These developments, and recent guidelines for reuse and conservation, allow for safer, economical and more adequate remedial measures. These guidelines and their application to selected case studies are briefly revised next.

## 2. ICOMOS RECOMMENDATIONS

Structures in cultural heritage buildings, by their very nature and history (material and assembly), present a number of challenges in conservation, diagnosis, analysis, monitoring and strengthening that limit the application of modern legal codes and building standards. Recommendations are desirable and necessary to ensure rational methods of analysis and repair methods appropriate to the cultural context. Therefore, an international committee has prepared recommendations, intended to be useful to those involved in conservation problems, ICOMOS (2003). In the particular case of seismic hazard, recent guidelines are detailed in Cecchi and Calvi (2011). The ICOMOS recommendations contain Principles, where the basic concepts of conservation are presented, and Guidelines, where the rules and methodology that a designer should follow are discussed.

The principles entail: General criteria; Research and diagnosis; and Remedial measures and controls. A multi-disciplinary approach is obviously required and the peculiarity of heritage structures, with their complex history, requires the organization of studies and analysis in steps that are similar to those used in medicine. Anamnesis, diagnosis, therapy and controls,

corresponding respectively to the condition survey, identification of the causes of damage and decay, choice of the remedial measures and control of the efficiency of the interventions. Thus, no action should be undertaken without ascertaining the likely benefit and harm to cultural heritage buildings. A full understanding of the structural behavior and material characteristics is essential for any project in cultural heritage buildings. Diagnosis is based on qualitative and quantitative approaches. The qualitative approach is based on direct observation of the structural damage and material decay as well as historical and archaeological research, while the quantitative approach requires material and structural tests, monitoring and structural analysis. Often the application of the same safety levels used in the design of new buildings requires excessive, if not impossible, measures. In these cases other methods, appropriately justified, may allow different approaches to safety. Therapy should address root causes rather than symptoms. Each intervention should be in proportion to the safety objectives, keeping intervention to the minimum necessary to guarantee safety and durability and with the least damage to heritage values. The choice between “traditional” and “innovative” techniques should be determined on a case-by-case basis with preference given to those that are least invasive and most compatible with heritage values, consistent with the need for safety and durability. At times the difficulty of evaluating both the safety levels and the possible benefits of interventions may suggest “an observational method”, i.e. an incremental approach, beginning with a minimum level of intervention, with the possible adoption of subsequent supplementary or corrective measures. The characteristics of materials used in conservation work (in particular new materials) and their compatibility with existing materials should be fully established. This must include long-term effects, so that undesirable side effects are avoided.

A combination of scientific and cultural knowledge and experience is indispensable for the study of cultural heritage buildings. The purpose of all studies, research and interventions is to safeguard the cultural and historical value of the building as a whole and structural engineering provides scientific support necessary to obtain this result. The evaluation of a building frequently requires a holistic approach considering the building as a whole rather than just the assessment of individual elements. The investigation of the structure requires an interdisciplinary approach that goes beyond simple technical considerations because historical research can discover phenomena involving structural behavior while historical questions may be answered by considering structural behavior. Knowledge of the structure requires information on its conception, on its constructional techniques, on the processes of decay and damage, on changes that have been made and finally on its present state.

In general the process towards the definition of remedial measures should include the following steps: (a) Acquisition of data: Information and investigation; (b) Historical, structural and architectural investigations; (c) Survey of the structure; (d) Field research and laboratory testing; (e) Monitoring, see Figure 1. Diagnosis and safety evaluation of the structure are two consecutive and related stages on the basis of which the effective need for and extent of treatment measures are determined. If these stages are performed incorrectly, the resulting decisions will be arbitrary: poor judgment may result in either conservative and therefore heavy-handed conservation measures or inadequate safety levels. Any assessment of safety is seriously affected by the uncertainty attached to data (actions, resistance, deformations, etc.), models, assumptions, etc. used in the research, and by the difficulty of representing real phenomena in a precise way.

The proposed methodology is in opposition with the past understanding, in which “conservation” was usually warranted by the powerfulness of the intervention, blind confidence existed in modern materials and technologies, a mistrust was present towards original or ancient materials and original resisting resources of the building, the value of original / ancient structure and structural principles was not recognized, the importance of previous studies was not fully recognize and significant negative experience accumulated, see Figure 2a. The modern understanding is to respect the authenticity of the structure and structural principles governing its response, to believe that conservation should lie on knowledge and understanding of the nature of the structure and real causes of possible damage or alterations, to adopt respectful interventions (minimal, non-intrusive and reversible), to give importance to knowledge (comprising historical, material and structural aspects) and to assume that studies prior to intervention and the intervention are multidisciplinary tasks requiring the cooperation of historians, architects, engineers, physicists, among others, see Figure 2b. Next, two recent case studies on interventions on cultural heritage buildings are presented as examples of an attempt to adopt the modern approach towards conservation.

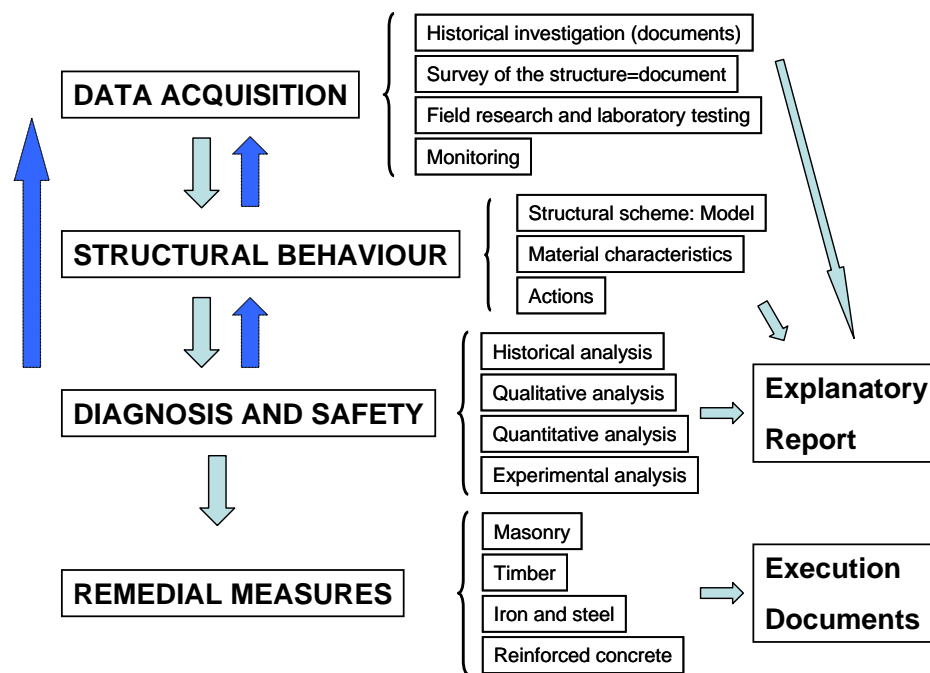

Figure 1: Icomos methodology.

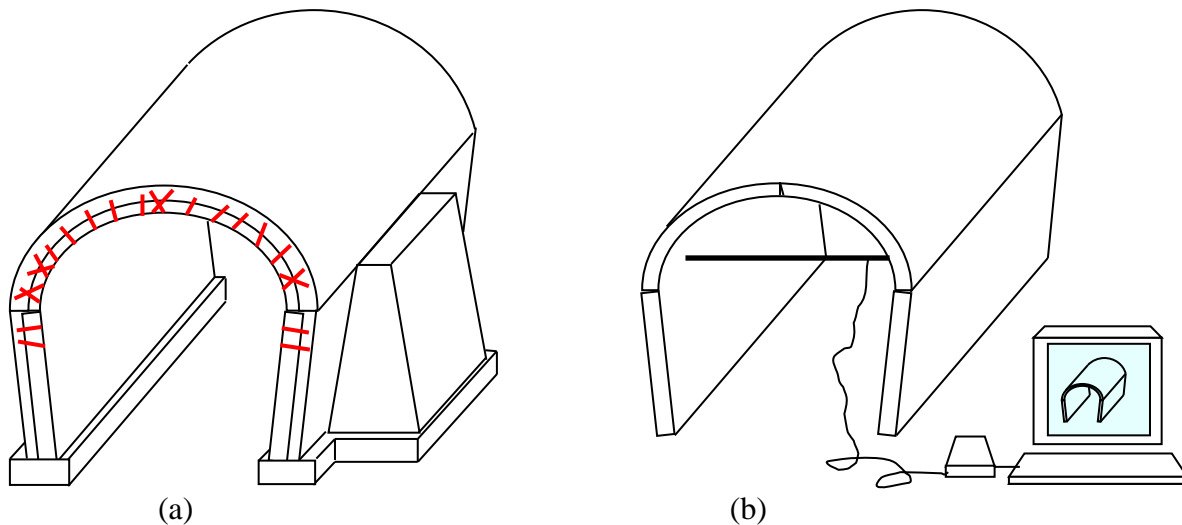

Figure 2: Two approaches in conservation: (a) past understanding; (b) present understanding.

### 3. CATHEDRAL OF PORTO

The foundation of the Cathedral of Porto is the middle of the 12<sup>th</sup> century. For 800 years, the settlement was a repository of added parts. In a framework of a continuous construction yard, the main fabrics are: Romanesque and proto-gothic, gothic, renaissance, mannerist, baroque, neoclassic, contemporary works from the first half of the 20<sup>th</sup> century and, finally, the present works. The governing thread of the program of the current intervention is to rehabilitate the previous restoration works, carried out in the first half of the 20<sup>th</sup> century, see Lourenço et al. (2004) for details on the evolution of the complex and the basis for the conservations works carried out. The aim is to reactivate, rehabilitate and up-grade the competence, where competence is understood as the capacity to perform adequately, of the structures, the materials, the shapes and also the space, assumed as a support for functionality. The intervention in the building was organized around five operations: removal of infestations, consolidation, water-tightness, ventilation and protection. Here, only some of the structural works are briefly reviewed.

Figure 3 shows selected views of the compound of the Cathedral, which has dimensions about 60 × 60 m<sup>2</sup> in plan, with a maximum height of the towers about 35 m. The compound includes the church, a gothic cloister on the south side, side chapels, a gallery on the north side, a sacristy, several chapels and other annexes. The church has a typical Latin cross, with three naves and five spans, and two rectangular towers facing west.

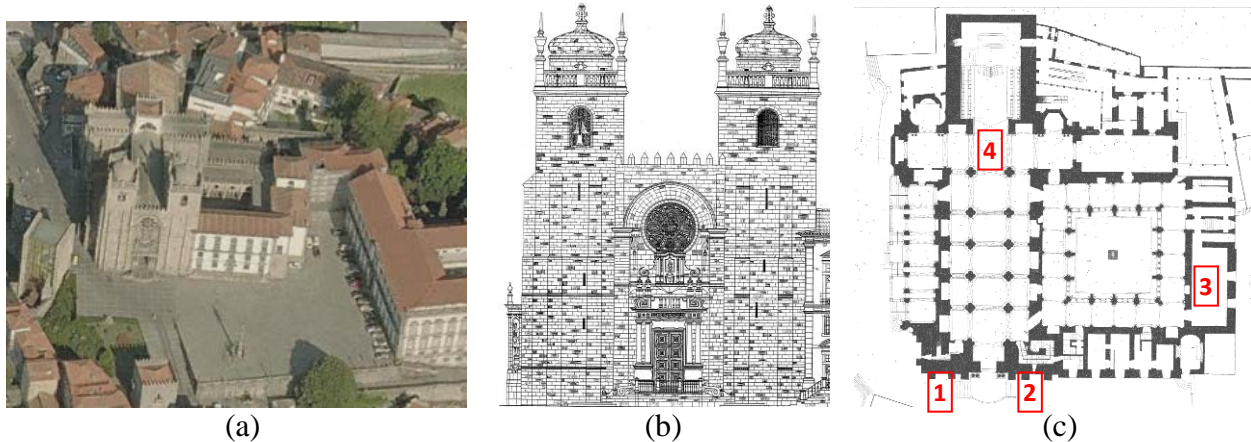

Figure 3: Aspect of the Cathedral: (a) Aerial View; (b) Façade; (c) Plan.  
 Legend: 1 – North Tower; 2 – South Tower; 3 – St. Vincent Chapel; 4 - Skylight.

### 3.1 Remedial measures in the towers

The cross section of the towers is approximately square with a side of 10.0 m and exhibits a variable thickness, with a minimum of 1.7 m at the base. The height of the towers is approximately 35 m, which means that the average stress at the base is around  $1.0 \text{ N/mm}^2$ . This value is rather low for regular granite masonry but it is rather high for rubble masonry (with or without mortar joints). In the main façade, two buttresses are apparent in each tower, see Figure 3b. The structure suffered several major modifications through time, which resulted in a very complex internal structure with different load bearing internal elements at each level. The structure of the towers cannot be understood from structural reasons and several openings are closed, facing staircases or vaults. The entrance for the towers is located at mid-height, with a connection between both towers from the top of the main vault. But the two towers have a rather different structure. The North tower (presently with the bells and clock) features a horizontal mid-level with stone slabs and architraves apparently supported in columns and stone struts. The South tower possesses an internal core with a staircase shaped helicoidally. The constitution of the masonry walls from the towers was characterized using visual inspection, removing stones of the outer leave in the interior of the tower and by using a boroscopic camera inserted in cracks or in holes drilled in joints, see Figure 4. From the inspection, it was possible to conclude that the three-leaf walls have external leaves of granite ashlar with a thickness ranging from 0.30 to 0.70 m, while the middle leaf is made from loose smaller stones and silty soil. The combination of heavy rain in Porto, strong winds in the top of the hill where the Cathedral is located, and the open joints in the external masonry face, results in a wet infill even in the summer and the continuous washing out of the infill.

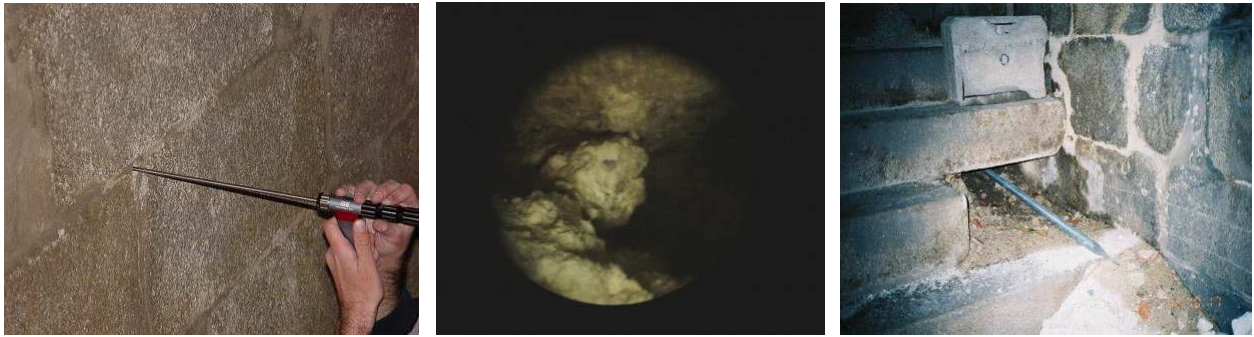

Figure 4: Visual inspection with boroscopic camera and inspection openings.

The towers exhibit distributed cracking and significant out-of-plane movements. The existing damage resulted in the past addition of three iron ties (date unknown), see Figure 5. Tie  $T_1$  presents a severely deformed anchorage and tie  $T_3$  is corroded and broken. The separation between the East and West façades of the South tower continued after tie  $T_3$  was broken. The masonry walls in the vicinity of the anchorages are also deformed, as expected due to the application of a large point load. The South tower is more damaged than the North tower, with severe cracks and out-of-plumb walls. Separation between the internal and external leaves of the walls is confirmed by the longitudinal cracking observed in most of the openings, with a maximum width of some centimeters.

The solution adopted for strengthening consists mostly of a steel ring in both towers, aiming at confining the structure along the two orthogonal directions, in the sole location possible, see Figure 6a,b. The rings are made with welded stainless steel plates (class AISI 316L), connected to the towers using long, inclined stainless steel anchorages inside of a cloth duct to prevent generalized injection, see Figure 6c-e. The length of the steel profiles is defined so that the elements can be transported to the location through the existing doors and can be easily assembled in situ, without any further welding. In the North tower, the ring also aims at providing a support for the stone pavement for the bells, as stone columns are much deteriorated and had no structural function and the stone struts have very deficient conception. The steel ring is made of channel profiles ( $240 \times 120$  mm and  $200 \times 100$  mm height). In the South tower, a set of two ties was provided to the ring, because it was possible for aesthetic reasons and they are a testimony of the ancient broken tie. The ring must cross the staircase at a selected location because the complex internal structure of the tower does not allow otherwise. Due to the lack of internal stiffening elements, a much stiffer steel frame is needed and the steel ring is made of H profiles ( $180 \times 180$  mm). Due to the bulging outwards of the East and South façades, and the severe cracks in the corners, several short ties have been added to the structure to stitch the East and South façades, and two long ties through the core of the South façade have been added to connect the West and East façades, see Figure 6f. Figure 6g presents details of the two types of anchorage plates adopted (circular plates and specially designed crosses).



Figure 5: Ancient tower ties, with deformed anchorage (T<sub>1</sub>) and broken tie (T<sub>3</sub>).

Given the cultural importance of the building and the significant damage in the South tower, a monitoring system was planned and installed. The system includes four waterproof crackmeters in the largest cracks, two strain gages for the new ties, two biaxial clinometers to measure the tilting of the tower, as well as temperature, humidity and wind sensors. The system includes also a GSM interface for remote monitoring. The measurements in the crackmeters (amplitudes lower than 0.3 mm) and clinometers (amplitudes lower than 0.6 mm/m) are rather small and they follow the temperature measurements. The wind speed measured indicates that the direction of the gust wind is North / Northwest, with velocities up to 150 km/h. An auto regressive exogenous model indicates that the measurements of the cracks are of good quality and the variations are explained by the environmental effects and not by crack opening. A similar conclusion holds for the measurements of stresses in the steel ties. The values in the tiltmeters are low but a rotation seems to be observed in the South tower, around 0.01°/year or 0.1°/decade.

### 3.2 Skylight in the transept

The skylight is located above the transept and presents different cracks, which occurred after the works carried out in the first half of the 20<sup>th</sup> century. In addition, infill material from the vault had recently fallen in the transept. The skylight is made of four walls supported in large arched windows opened in the 18<sup>th</sup> century, with the exception of the East façade with exhibits no opening, see Figure 7a. It has a square plan with 7.5 m side, walls with 6.5 height and 0.65 m thickness. The thickness is reduced to 0.4 m above the vaults and, again, to 0.2 m in the battlements. Buttresses can be found in each corner and a ribbed stone vault makes the ceiling, further topped by a timber double slope roof. The masonry in the walls is of very low quality, made of rubble stone and weak lime mortar. The openings form pointed arches, supported at the thirds of the span with T-shaped columns. The vault is made with stone slabs with a thickness between 0.14 and 0.54 m. Rubble loose infill was removed on top of the vault (about 10 m<sup>3</sup>).

The three walls with windows are cracked at the arch key, with maximum crack widths of 10, 1 and <0.5 mm, in the façades West, North and South, respectively. These walls are also bulging outwards. Figure 7b shows the main crack in the West façade, which crosses the entire section of the wall. Smaller cracks can be also observed closer to the buttresses, under the opening, together with horizontal cracks in the window columns due to bending. The most severe crack in the interior has a width of 25 mm and shows that the vault is separated from the wall in the West façade. Due to this crack, the stone slabs of the vault are no longer supported in the side rib and a settlement of about 20 mm can be observed at the key if the vault.



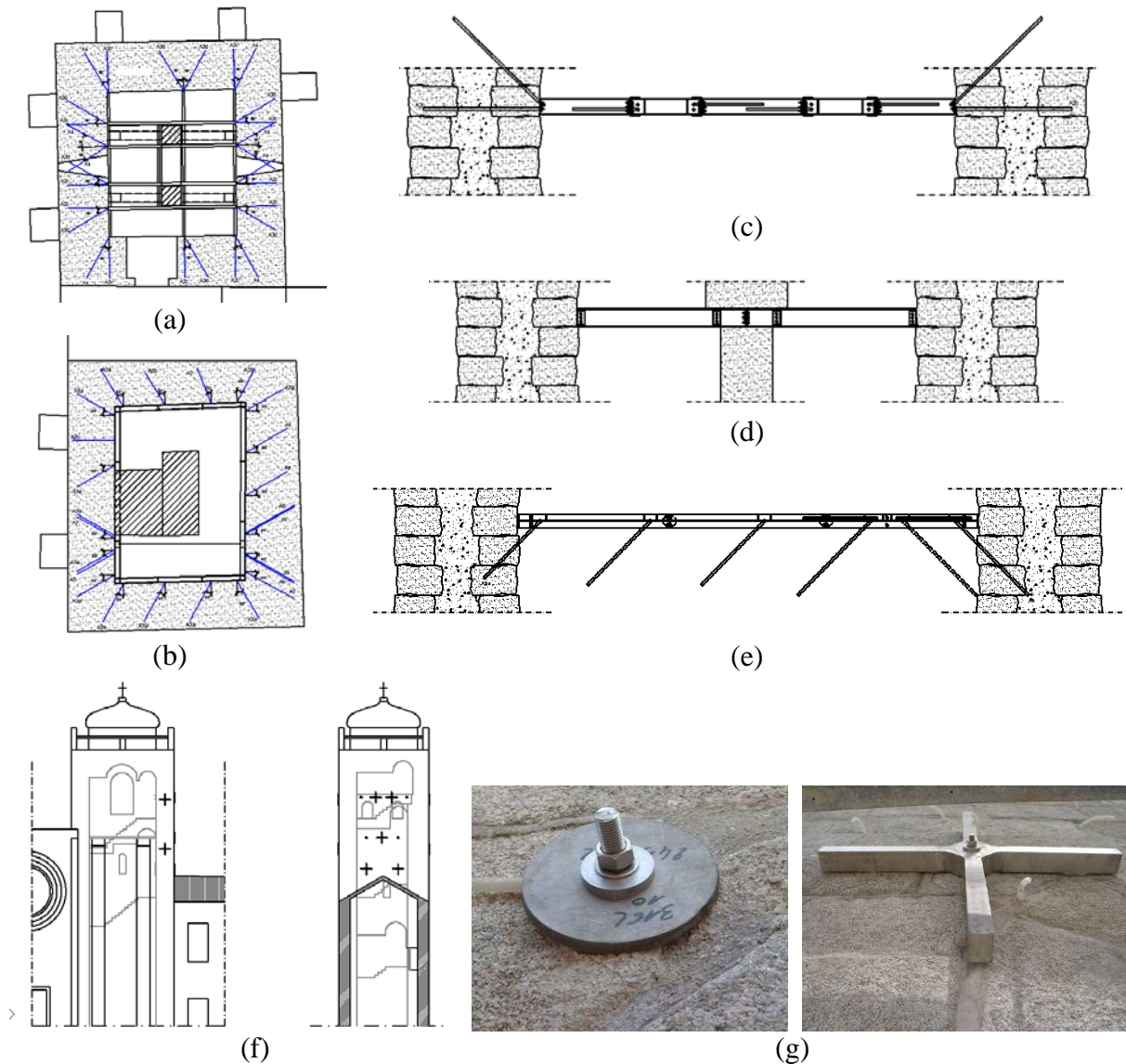

Figure 6: Aspect of the strengthening of the towers: (a) Ring for the north tower; (b) Ring for the south tower; (c) North-south section for north tower; (d) West-east section for north tower; (e) Typical section for south tower; (f) Additional ties in the west and south façades of the south tower; (g) Details of the anchorage plates.

The observation of the damage in the skylight, together with the local relief, the severe separation between the East façade and the chancel, the old documents indicating consolidation and enlargement of foundations and the bulging of the walls of the nave indicate that soil settlements and weak foundations can be the main cause of damage. A finite element model of the skylight was used to understand and justify the existing damage. The actions considered include the self-weight of the structure, the weight of the infill, the seismic action and differential temperature. The results for the combination of self-weight plus rubble infill provided a maximum tensile stress found lower than  $0.1 \text{ N/mm}^2$  and located in the window-sills and ribs. The skylight should have minor or no damage under self-weight and infill. Seismic loading and temperature were then added to the structure, aiming at explaining the damage, see Figure 8a,b. Even if the deformation

for seismic loading has some resemblance with the observed movements in the structure, the stresses found are too low to provoke any damage. The deformed mesh associated with the differential temperature indicates that the walls move to the exterior and suffer significant bending, with significant curvatures in the columns. Still moderate stresses are found and the deformation is not in agreement with the observed movements, meaning that the temperature effect is relevant but should not be the main cause of the damage. A full model of the church was then prepared to analyze the influence between the skylight, the adjacent structure and the soil, see Figure 8c. Very high tensile stresses are found in the skylight and the deformation is similar to the one observed in the structure, confirming that this is the major cause of damage. The remedial measures are given in Lourenço et al. (2004).

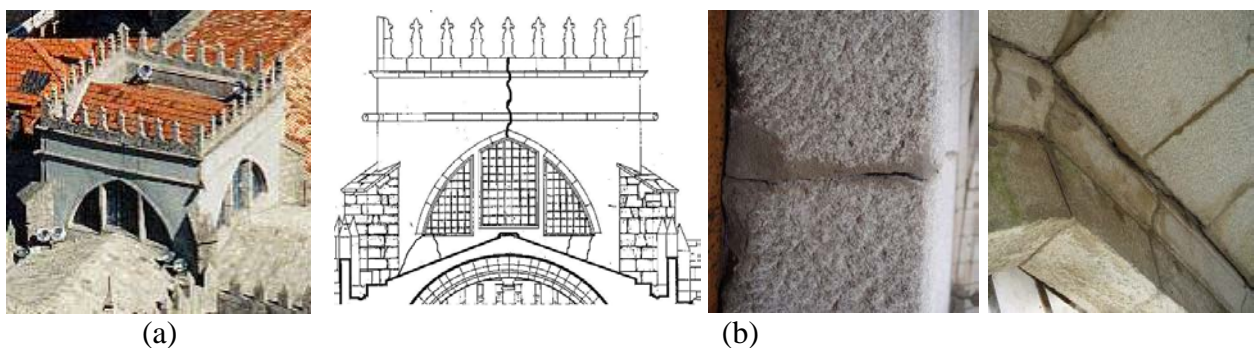

Figure 7: Skylight: (a) Aerial view; (b) Cracks in façades, windows columns and vaults.

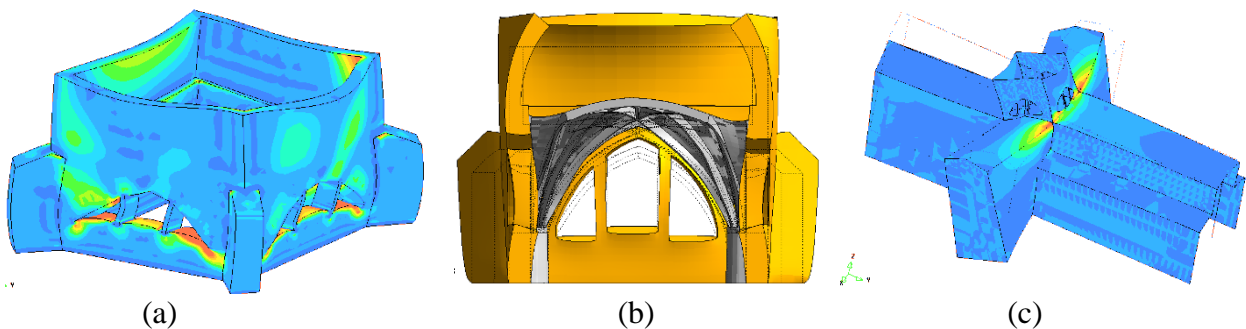

Figure 8: FEM analysis: (a) Live loads; (b) Temperature variation; (c) Dead load for full model.

#### 4. THEOLOGICAL SCHOOL IN BRAGA

This building has  $110 \times 15 \text{ m}^2$  in plan and 5 floors, as shown in Figure 9a. The inner walls and slabs are made of an early 1930s reinforced concrete structure, while the external walls are made of ashlar granite masonry. Floor 5 is an attic with a timber structure, while floors 3 and 4 were used as students' dormitory in the past. The slabs at these levels are supported in beams supported in the external masonry walls. The internal walls between floors 2/3, 3/4 and 4/5 are made in reinforced concrete. Floor 2 is used as office rooms for lecturers and this floor is supported in a reinforced concrete beams grid. The objective was to use the upper floors as an archive, which required a safety assessment and a strengthening design. For details see Lourenço et al. (2004).

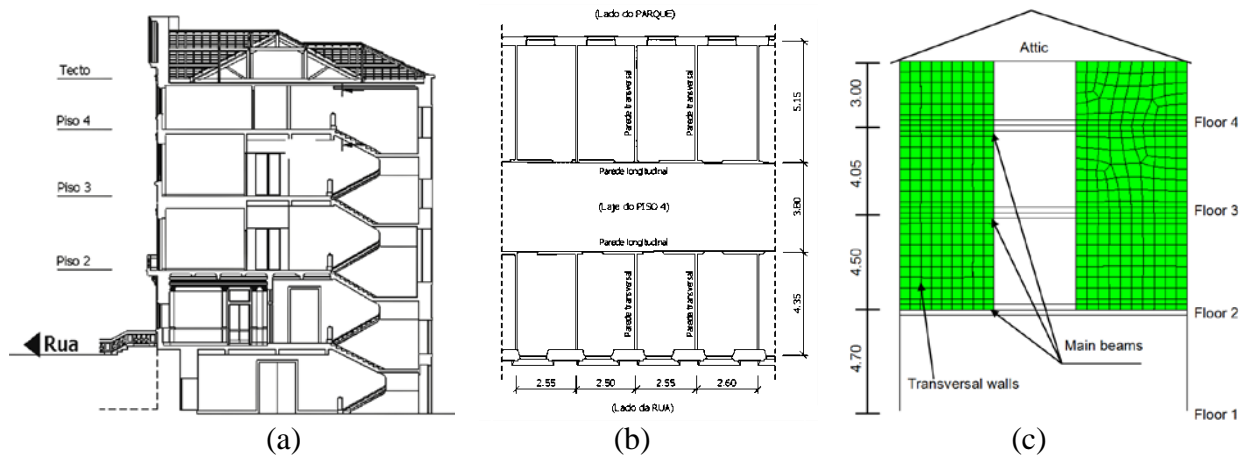

Figure 9: Theological school: (a) Vertical section; (b) Plan; (c) Main transversal structure.

Figures 9b,c present the geometrical survey of the building and the main structure. Cores and steel samples were obtained from the building in order to characterize the materials used. The transversal walls are separated each 2.6 m, with asymmetric location of the longitudinal walls. The thickness of the external masonry walls varies between 0.30 and 0.60 m. The transversal beams have cross sections of  $0.25 \times 0.50 \text{ m}^2$  (floors 3 and 4) and  $0.30 \times 0.60 \text{ m}^2$  (floor 2). The thickness of the slabs is 0.12 m and the internal walls have a thickness of 0.06 m. The concrete strength found was  $24.6 \text{ N/mm}^2$  (slabs) and  $11.9 \text{ N/mm}^2$  (walls). All the reinforcement found is unribbed and mild steel. The slabs have a single layer of reinforcement with  $\phi 3/8''@0.125$  for the main reinforcement and  $\phi 3/8''@0.25$  for the secondary reinforcement. The walls have also a single layer of reinforcement with  $\phi 3/16''@0.25$  in the vertical direction and  $\phi 5/32''@0.25$  in the horizontal direction. The lower reinforcement in the transversal beams is  $3\phi 1''$  (floors 3 and 4) and  $4\phi 1\frac{1}{4}'' + 4\phi 1''$  (floor 2). Besides the dead load, for the current use of the building the live load according to the Portuguese code is  $3.0 \text{ kN/m}^2$  in general with  $5.0 \text{ kN/m}^2$  is the access zones. With the new use, the planned live load is  $14.8 \text{ kN/m}^2$  for floor 2,  $13.5 \text{ kN/m}^2$  for floor 3 and  $11.0 \text{ kN/m}^2$  for floor 4.

#### 4.1 Analysis of the slabs stability

The reinforcement that is present in the slabs is adequate for the previous loads but it is clearly insufficient for the new loads. The proposal of the architect responsible for the works was to adopt three archive shelves with a height of 2.40 m and a base of 0.40 m, see Figure 10, which implies a reinforcement amount twice the existing. The original proposal is possible with a new supporting structure of steel profiles HEB 100, placed transversally in the rooms, and supported by steel angles placed close to the walls. On top of this structure, an OSB new floor would be placed, with a total cost for the solution of about  $100 \text{ USD/m}^2$ . The proposed alternative was to use two taller shelves close to the walls and a shorter shelf in the center, in order to reduce the bending moment, allowing even to provide more room for stocking.

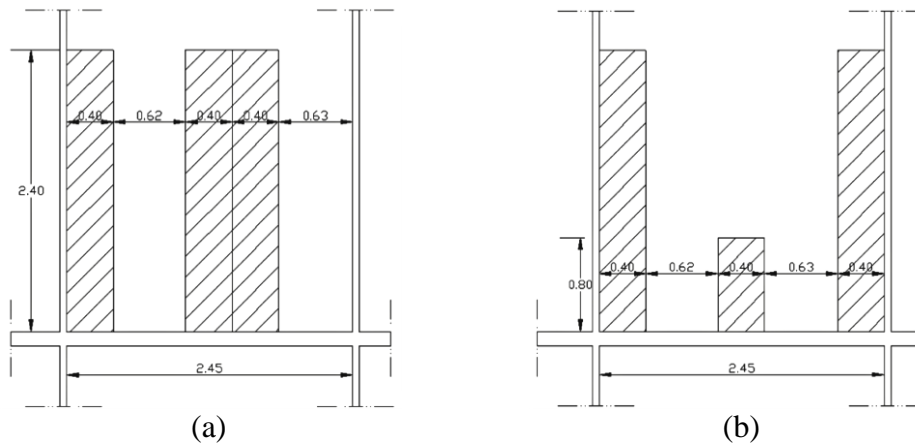

Figure 10: Proposal for book archive: (a) Original; (b) New.

#### 4.2 Analysis of the main structure stability

A finite element model was used for the global stability of the structure. The results allow confirming the large stiffness of the internal walls and the asymmetry of the response, see Figure 11a. The analysis of the principal compressive stresses shows that the load is transferred to the external walls, with a behavior similar to a deep beam and using the main beam of level 2 as a “tie” subjected to large flexure, see Figure 11b. The bending moment of the main beams obtained using a linear elastic approach and the failure of the structure using non-linear analysis is shown in Figures 11c,d. The asymmetric deformation and the large stiffness of the walls led to large bending moments producing tensile stress in the upper fibers (60 kN.m in the beam of level 2, in the connection with the left transverse wall). Therefore, the global stability is ensured by the flexural capacity of the nodes in the connection between beams and walls, in a zone where the amount of upper reinforcement is rather low. Figure 11d shows the attempt of the structure to follow a strong redistribution, with a fast progression of a horizontal crack between the walls and the beam in level 2. As the lower reinforcement in the beams is insufficient to carry out the load corresponding to the new use, the structure must be strengthened.

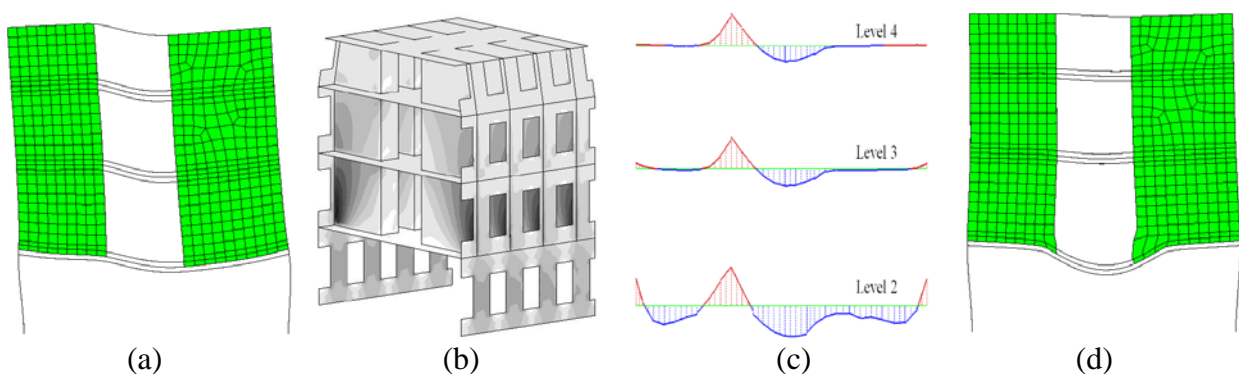

Figure 11: Results for the structural analysis: (a) Deformed mesh; (b) Compressive principal stresses; (c) Bending moments in main beams; (d) Failure from non-linear analysis.

Two possibilities of strengthening were analyzed: (a) a steel beam grid and new columns supporting level 2; (b) a suspension structure for the main beams. Given the aesthetic implications, the usage limitation and the cost, the latter solution was adopted, see Figure 12. Truss steel structures have been added between level 4 and the roof, in between the existing

timber trusses, combined with  $\phi 40$  mm suspension bars. The system supports the beams of levels 2 to 4 and load was transferred using hydraulic jacks.

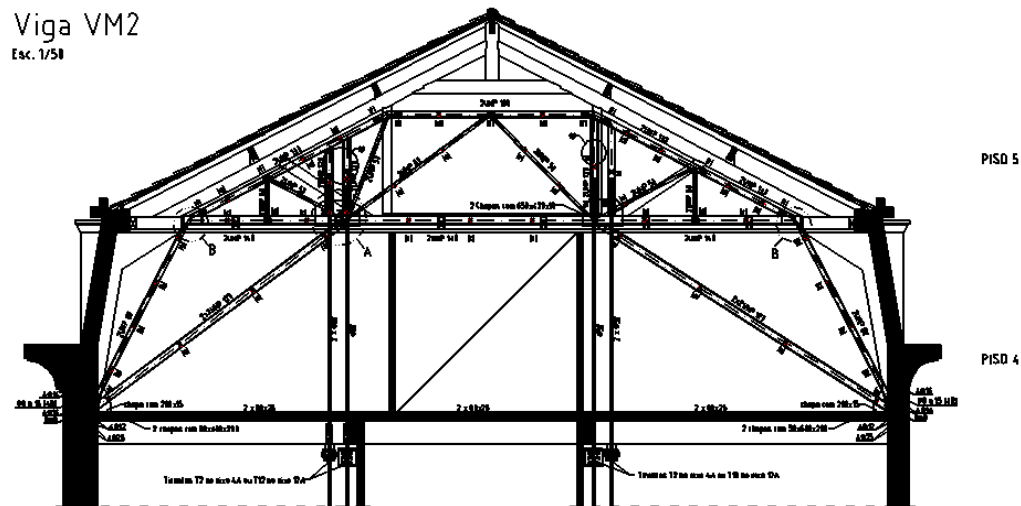

Figure 12: Adopted strengthening solution.

## 5. CONCLUSIONS

Conservation engineering is a new, complex and exciting field, which requires specific education. Engineers are still educated today much in the same way as they were educated decades ago, oriented to new construction, even if there are currently clear methodologies to address the conservation of existing structures in general, and cultural heritage buildings in particular. A scientific methodology with a sound basis is available, but experience and personal judgment remain a key issue

Two case studies have been presented on masonry and reinforced concrete buildings. Masonry is a material used in construction for over 10,000 years, whereas reinforced concrete is an industrialized material that expanded worldwide in the 2<sup>nd</sup> half of the 20<sup>th</sup> century and became the most used construction material. Masonry is usually a very durable material, whereas reinforced concrete is more susceptible to corrosion. Still, the modern understanding is that fabric should be preserved in both cases and minimum interventions should be adopted, as shown. The masonry case study required structural repair, due to ageing, settlements and alterations, which provoked a loss of capacity. The reinforced concrete case study required strengthening because the use was changes (higher live load) and because the structure presented originally insufficient safety, according to current codes. Both cases stress the need to clearly understand the behavior of complex structures, to adequately assess the need of structural strengthening and to analyze the cost of possible solutions at an early design phase.

## 6. REFERENCES

ICOMOS (2003), *Recommendations for the analysis, conservation and structural restoration of architectural heritage*.

Cecchi, R. & Calvi M. (2011), Guidelines for evaluation and mitigation of seismic risk to cultural heritage, Gangemi.

Croci, G. (1998), *The conservation and structural restoration of architectural heritage*, WIT Press.

Farrar, C.R., et al. (2004) *A review of structural health monitoring literature: 1996-2001*. Los Alamos,, New Mexico: Los Alamos National Laboratory.

Lourenço, P.B. (2002). Computations on historic masonry structures. *Progress in Structural Engineering and Materials*, 4(3), 301-319.

Lourenço, P.B., Barbosa Lourenço, J. & Oliveira, D.V. (2004), “*Inspecção e reabilitação do Seminário Conciliar de Braga*”, BE 2004 – Encontro Nacional de Betão Estrutural, Universidade do Porto, Porto, pp. 815 – 822.

Lourenço, P.B., Melo, A. & Carneiro, M. (2004), “*Remedial measures for Cathedral of Porto: A post-modern conservation approach*”, Structural analysis of historical constructions IV, Eds. C. Modena, P.B. Lourenço and P. Roca, A.A. Balkema Publishers, Leiden, pp. 51 – 62.

McCann, D.M., Forde, M.C. (2001), Review of NDT methods in the assessment of concrete and masonry structures, *NDT & E International*, 34 (2), pp. 71–84

Theodossopoulos, D., *Structural design in building conservation*, Routledge (2012)