

## **Design of RC Thin Surface Structures**

Késio Palácio, Paulo B. Lourenço, Joaquim A. O. Barros

Report 04-DEC/E-06

*The present research has been carried out under  
“Onderzoek protocol 8857”  
Ministry of Transport, Public Works and Water Management  
The Netherlands*

Date: March 2004

No. of Pages: 59

Keywords: reinforcement design, reinforced concrete, shell elements



Escola de  
Engenharia



Departamento de  
Engenharia Civil



Universidade  
do Minho

## Contents

<b>1 Design of RC Plates and Shells .....</b>	<b>3</b>
<b>2 Design Sandwich Models for Slabs and Shell Elements .....</b>	<b>6</b>
2.1 Design model for slabs according to normal yield criteria.....	6
2.2 Three-Layer Model of Marti .....	8
2.3 Three-Layer Approach of Lourenço-Figueiras .....	12
<b>3 Cracked Three-layer Model.....</b>	<b>21</b>
3.1 Cracked Membrane Model.....	21
3.2 Cracked Three-layer Model with no Transverse Shear .....	29
3.2.1 <i>Introduction of the Concepts of the CMM</i> .....	30
3.3 Cracked Three-layer Model with Transverse Shear .....	34
3.3.1 <i>Shear-design Method of Adebar and He</i> .....	35
3.3.2 <i>Introduction of the CMM into the Shear-design Method</i> .....	41
<b>4 Numerical Implementation .....</b>	<b>42</b>
4.1 Numerical Routines .....	44
<b>5 Validation and Application .....</b>	<b>50</b>
5.1 Validation 1 - Test ML7 and ML9 .....	50
5.2 Validation 2 - Test Specimen SE7.....	51
5.3 Application Example .....	52
<b>6 Conclusions.....</b>	<b>57</b>
<b>7 References .....</b>	<b>58</b>

# 1 Design of RC Plates and Shells

In a companion report, Palacio *et al.* (2003), the problem of designing orthogonally reinforced, cracked concrete thin surface elements has been addressed. The formulation is now extended to plates and shells. The treatment of this case is more complex than membrane elements due to the need of considering flexural and torsional moments ( $m_x, m_z, m_{xz}$ ), and out-of-plane shear forces ( $v_x, v_z$ ) into the design, see Figure 1.1. In the following, the term slab (Figure 1.1a) will be used for plates in which moments and out-of-plane shear forces are predominant, while the term shell element (Figure 1.1b) will be used for cases involving general combinations of forces and moments.

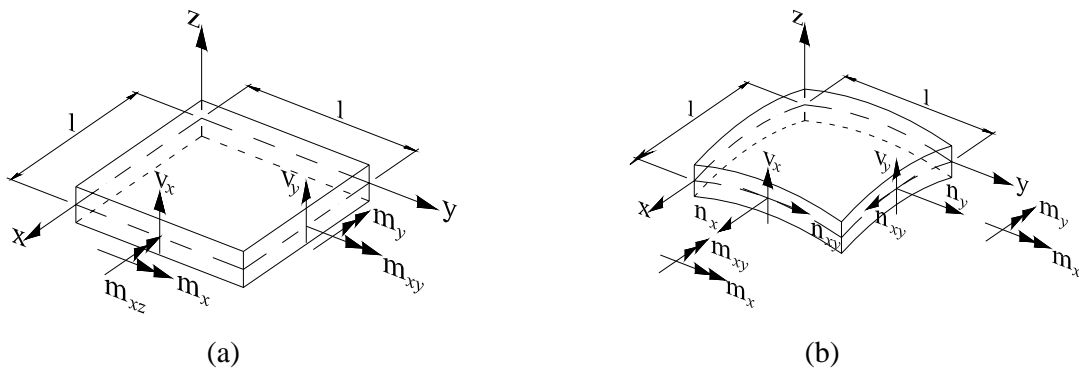

Figure 1.1 – Stress resultants on thin surface elements: a) slab; b) shell

In recent decades, several theoretical models for the design and analysis of RC thin surface elements with flexure and out-of-plane shear forces have been proposed, namely *the three-layer model* of Marti (1991), *yield criteria for slabs with orthogonal reinforcement*, Nielsen (1964, 1964a), and *the three-layer approach* of Lourenço and Figueiras (1995). Basically, all of them are formulated on a sandwich model of two or three layers, see Figure 1.2, by establishing the equilibrium conditions between the applied forces and moments and internal forces in the reinforcement and concrete. In these models, generally the two outer layers carry the membrane stresses originating from the six local force components ( $m_x, m_z, m_{xz}, n_x, n_y, n_{xz}$ ) and the inner layer, in the case of three-layer model, carries the transversal shear stresses due to out-of-plane shear forces.

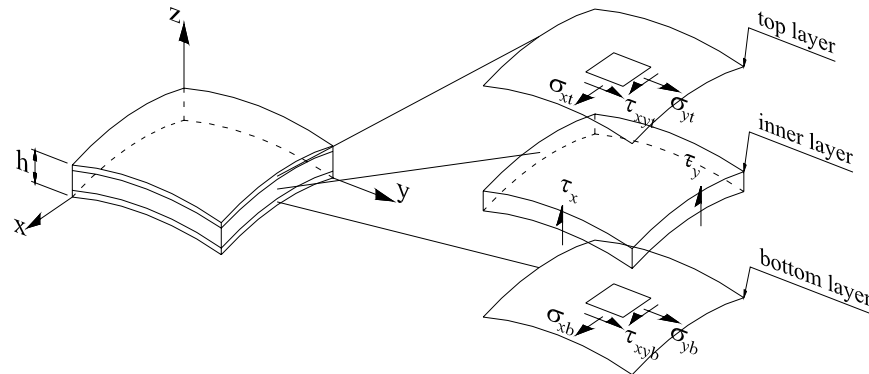

Figure 1.2 – Sandwich model of three layers

The three-layer approach of Lourenço and Figueiras (1995) is a general plastic method for the automatic reinforcement design of slab and shell elements, based on equilibrium and strength conditions, in which slab and shell elements are analyzed globally and not as two membrane outer layers, as given in the other models. However, the design equations from this model do not take into account the influence of the out-of-plane shear forces and nonlinear effects of concrete and steel as tension stiffening and softening. Thus, in the present work, the effect of out-of-plane shear forces and the concepts of the Cracked Membrane Model (CMM), Kaufmann (2002), are extended into the formulation, in order to account for tension stiffening and softening. The result is a new theoretical model for cracked, orthogonally reinforced, concrete elements subject to a general combination of forces and moments. In addition to these advances, the design equations for the new model were implemented in a computer program and incorporated into the DIANA 8.1 finite-element package through its post-processing interface, extending the use of the finite-element package, from an analysis tool to a design tool for RC slabs and shell elements.

Chapter 2 provides design equations for the formulations based on sandwich models currently proposed in relevant design codes, and on experimental investigations. In the following Chapter 3, the new design equations for cracked, orthogonally reinforced, concrete elements subject to a general combination of forces and moments, is developed, extending the three-layer approach of Lourenço and Figueiras (1995) and the concepts of CMM. In Chapter 4 the numerical procedure developed to implement the design equations is presented. Chapter 5 shows the validation and application examples, with comparisons between the novel



formulation and the traditional formulations. Finally, Chapter 6 presents the conclusions of the present work.

## 2 Design Sandwich Models for Slabs and Shell Elements

The current design practice of RC thin surface structures may be divided into two interrelated tasks: 1) global analysis to determine the local stress resultants due to the applied loads; and 2) section analysis to determine how the reinforced concrete responds to these local stress resultants. For the first task, it is a standard practice among designers to use linear finite element programs in the case of complex structures. For the second task, a rational design method is usually used to predict the element behavior at ultimate load.

In the past three decades a considerable number of analytical and experimental works have been carried out to study the structural behavior of elements that are subjected to the three membrane forces only, as for example the *yield criteria for disks with orthogonal reinforcement*, Nielsen (1971), *the modified compression field theory (MCFT)* from Vecchio and Collins (1986) and the *cracked membrane model (CMM)* of Kaufmann and Marti (1998). For slab elements, subjected to moments only, a number of considerable analytical and experimental works have also been carried out. However, for concrete elements subjected to a more general combination of moments and forces, as in the case of shell elements, just a scarce number of works on the subject can be found. These works generally handle design by subdividing shell elements into layers, which allows the design of shell and slab elements similarly to a plane stress problem.

Basically the approaches for the design of RC slabs and shell elements based on sandwich models differ on geometry and material modeling, and the consideration of out-of-plane shear forces. In the case of geometry modeling, the number of layers and how these layers are modeled (treatment of the internal lever arms of reinforcement and concrete layers) are the aspects considered. In the case of material modeling, the constitutive laws of reinforcement and concrete as well as compatibility conditions are the aspects taken into account.

Below, different approaches that have been proposed for the design of RC thin surface elements subjected to moments and forces are described.

### 2.1 *Design model for slabs according to normal yield criteria*

Applying limit analysis and assuming the concepts of a two-layer model, see Figure 2.1, Nielsen (1964) developed yield criteria for orthogonally reinforced slabs under the

following assumptions: a) no influence of out-of-plane shear forces; b) reinforcement in two layers, at the top and bottom; c) resultant forces in the concrete and reinforcement are located at the same level; and d) low reinforcement ratios so that steel can be stressed to yielding. The yield criteria obtained, which is similar to the shape of the yield criteria of RC membrane elements, is given as

$$\begin{aligned}
 Y_1 : m_{xz}^2 &= (m_{px} - m_x) \cdot (m_{pz} - m_z) \\
 Y_2 : m_{xz}^2 &= (m'_{px} + m_x) \cdot (m_{pz} - m_z) \\
 Y_3 : m_{xz}^2 &= (m_{px} - m_x) \cdot (m'_{pz} + m_z) \\
 Y_4 : m_{xz}^2 &= t_p^2
 \end{aligned}
 \tag{2.1}$$

where  $m_{px}$  and  $m'_{px}$  are the positive and negative yield moments in pure bending perpendicular to the  $x$ -axis,  $m_{py}$  and  $m'_{py}$  are the positive and negative yield moments in pure bending perpendicular to the  $y$ -axis, and  $t_p$  is the yield moment in pure torsion.

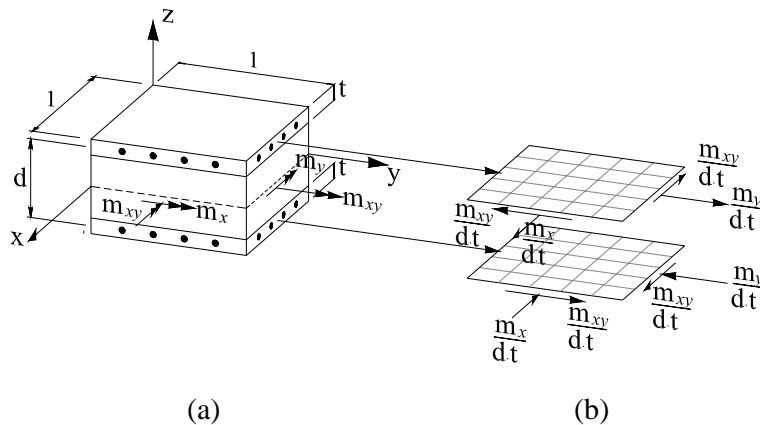

Figure 2.1 – Sandwich model of two layers: a) definition; b) membrane outer layers with resulting in-plane stresses

As one can observe from Figure 2.1, the outer layers play the role of resisting in-plane forces caused by moments, i.e., they work as two membrane layers. They are assumed to be of equal thickness  $t$  and having  $d$  as single value for all the lever arms. As mentioned before, this means that, the resultant forces in concrete and reinforcement are located at the same

level, which is an approximation. If different lever arms are considered for the resultant forces, it is no longer possible to isolate the outer layers and to treat them as membrane layers.

Using similar procedures to the ones adopted to determine the design equations for RC membrane elements, see Palacio *et al* (2003), Nielsen (1964) developed the design equations for slabs, which are currently found in the design provisions of the Eurocode 2. The design equations are:

$$\begin{aligned}
 &\bullet \quad m_x \geq -|m_{xy}| \Rightarrow \begin{cases} m_{px} = m_x + |m_{xy}| \\ m_{py} = m_y + |m_{xy}| \end{cases} \\
 &\bullet \quad m_x < -|m_{xy}| \Rightarrow \begin{cases} m_{px} = 0 \\ m_{py} = m_y + \frac{m_{xy}^2}{|m_x|} \end{cases} \\
 &\bullet \quad m_y \leq |m_{xy}| \Rightarrow \begin{cases} m'_{px} = -m_x + |m_{xy}| \\ m'_{py} = -m_y + |m_{xy}| \end{cases} \\
 &\bullet \quad m_y > |m_{xy}| \Rightarrow \begin{cases} m'_{px} = m_x + \frac{m_{xy}^2}{|m_y|} \\ m'_{py} = 0 \end{cases}
 \end{aligned}$$

With the bending yield moments  $m_{px}$ ,  $m'_{px}$ ,  $m_{py}$  and  $m'_{py}$  calculated above, the necessary reinforcement may be found by applying traditional beam design.

However, as said before, these expressions do not include the interaction between the different reinforcement layers and compression resultants in concrete. This simplification, as demonstrated by Gupta (1986), is not on the safe side.

## 2.2 Three-Layer Model of Marti

An important contribution to the design of RC slab and shell elements has been given by Marti, who addressed the problem in a rational and systematic way through a series of theoretical studies and experimental investigations (1987, 1990, 1991). As a result of these works, a sandwich model of three layers was formulated, see Figure 2.2.



The three-layer model of Marti (1990, 1991) provided important advances in the treatment of the design of slab and shell elements, by including the out-of-plane shear forces. Thus, in this model, see Figure 2.2b, while the outer layers carry moments and membrane forces, the intermediate layer has the task of carrying out-of-plane shear forces,  $v_x$  and  $v_y$ , with the help of a truss mechanism. The treatment of the out-of-plane shear forces in this model is a result of an analogy between a beam, consisting of two flanges linked by a web, and a slab, conceived as a sandwich in which the intermediate layer behaves like a beam web, see Figure 2.2c. The principal shear force  $v_0$  in Figure 2.2c is given by

$$v_0 = \sqrt{v_x^2 + v_y^2} \quad (2.2)$$

which is transferred along a direction making an angle

$$\alpha_0 = \tan^{-1} \left( \frac{v_x}{v_y} \right) \quad (2.3)$$

with the  $x$ -axis. Perpendicular to this direction, there is obviously no transverse shear force.

In this model, as in the previous from Section 2.1, the middle planes of the outer layers are assumed to coincide with the middle planes of the reinforcement meshes and equal thickness  $t$  is also assumed for both membrane layers. Therefore, a single value  $d$  is considered for all the lever arms.

In the following items, the procedures for the reinforcement design of slab and shell elements through this sandwich model are described.

#### a) Dimensioning of the inner layer

Provided that the nominal shear stress due to the principal shear force,  $v_0/d$ , does not exceed a certain fraction of the concrete tensile strength, one may assume that there are no diagonal cracks in the inner layer. In this case, no transverse reinforcement has to be provided, and the in-plane reinforcement in the outer layers does not need to be strengthened to account for transverse shear. But, if the diagonal cracking limit is exceeded, transverse

reinforcement is necessary and the in-plane reinforcement must be strengthened. From Figure 2.2c, the value of the transverse reinforcement is given by

$$A_{sz} f_{ydz} = v_0 \tan \theta_v \quad (2.4)$$

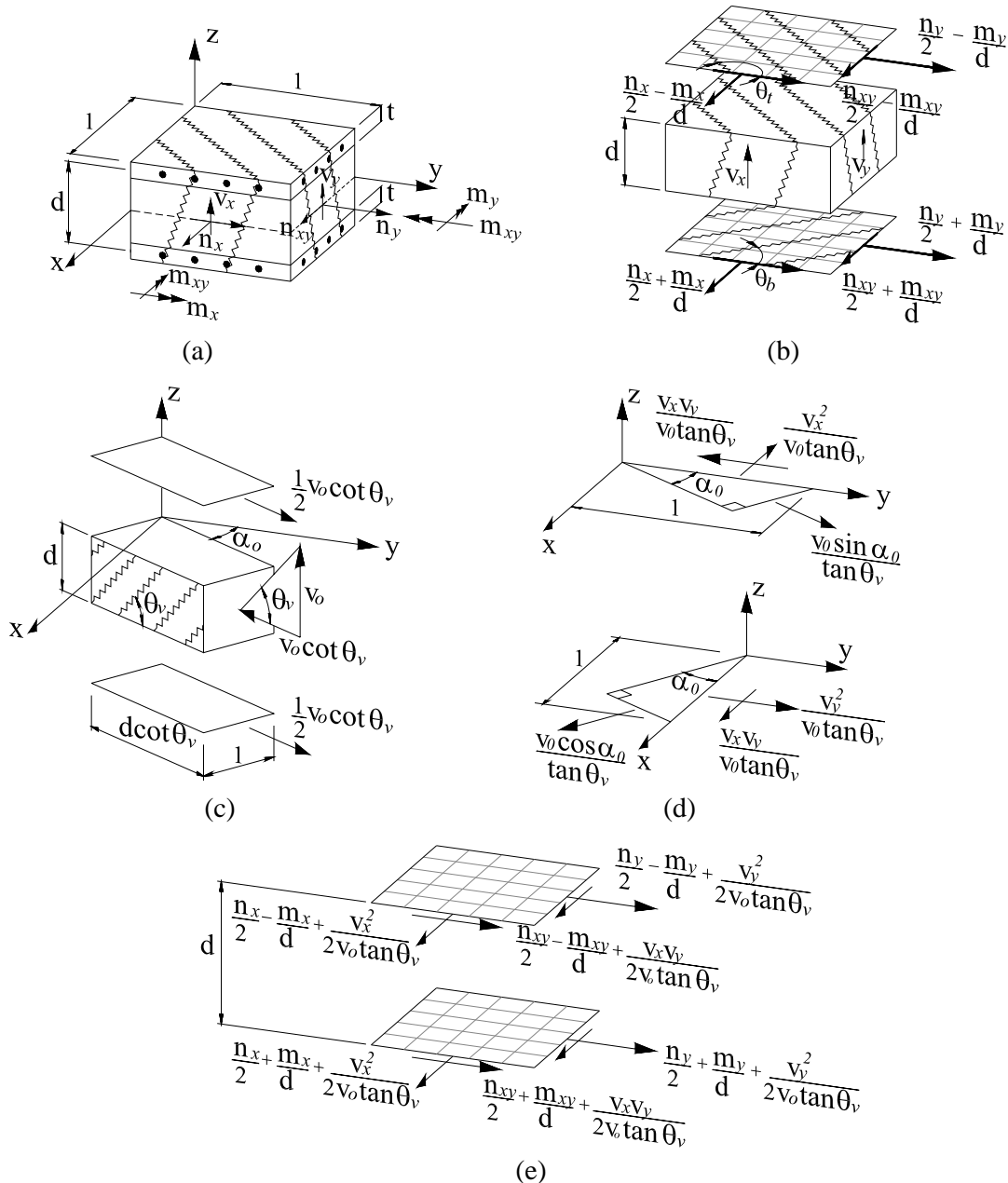

Figure 2.2 -Three-layer model: a) definition; b) outer and inner layers; c) diagonal compression field in the cracked inner layer; d) membrane forces equilibrating  $v_0 \cot \theta_v$ ; e) forces acting on the outer layers.

Yet from Figure 2.2c, the horizontal component of the diagonal compression in the inner layer,  $v_o \cot \theta$ , must be balanced by membrane forces in the outer layers, which can be determined from the free-body diagrams of Figure 2.2d. Then, these forces will be added to the existing membrane forces in the outer layers, see Figure 2.2e.

### b) Dimensioning of the outer layers

The outer layers are assumed equal to membrane elements, meaning that procedures for reinforcement design of membrane elements, see Nielsen (1971), can be employed. Then the necessary reinforcement areas  $A_{sx}$  and  $A_{sy}$  for an orthogonally reinforced membrane element are given by

$$A_{sx} f_{ydx} = RN_x + \frac{1}{\cot \theta} RN_{xy} \quad (2.5a)$$

$$A_{sy} f_{ydy} = RN_y + \cot \theta RN_{xy} \quad (2.5b)$$

where  $RN_x$ ,  $RN_y$  and  $RN_{xy}$  are the resultant membrane forces. Applying this to the two membranes outer layers of the sandwich model, the following requirements are obtained:

- Bottom reinforcement

$$A_{sxb} f_{ydx} = \frac{n_x}{2} + \frac{m_x}{d} + \frac{v_x^2}{2v_0 \tan \alpha_0} + \frac{1}{\cot \theta_b} \left[ \frac{n_{xy}}{2} + \frac{m_{xy}}{d} + \frac{v_x v_y}{2v_0 \tan \alpha_0} \right] \quad (2.6a)$$

$$A_{syb} f_{ydy} = \frac{n_y}{2} + \frac{m_y}{d} + \frac{v_y^2}{2v_0 \tan \alpha_0} + \cot \theta_b \left[ \frac{n_{xy}}{2} + \frac{m_{xy}}{d} + \frac{v_x v_y}{2v_0 \tan \alpha_0} \right] \quad (2.6b)$$

- Top reinforcement

$$A_{sxt} f_{ydx} = \frac{n_x}{2} - \frac{m_x}{d} + \frac{v_x^2}{2v_0 \tan \alpha_0} + \frac{1}{\cot \theta_t} \left[ \frac{n_{xy}}{2} - \frac{m_{xy}}{d} + \frac{v_x v_y}{2v_0 \tan \alpha_0} \right] \quad (2.6c)$$

$$A_{syt} f_{ydy} = \frac{n_y}{2} - \frac{m_y}{d} + \frac{v_y^2}{2v_0 \tan \alpha_0} + \cot \theta_t \left[ \frac{n_{xy}}{2} - \frac{m_{xy}}{d} + \frac{v_x v_y}{2v_0 \tan \alpha_0} \right] \quad (2.6d)$$

These design equations correspond to dimensioning reinforcement in the yield Regime 1 for membrane elements, which was discussed in detail by Palacio *et al.* (2003).

In conclusion, the three-layer model of Marti (1991) brings advances in the treatment of shear design. However, the treatment of in-plane design basically remains the same as given by Nielsen (1964).

### **2.3 Three-Layer Approach of Lourenço-Figueiras**

This sandwich model was proposed by Lourenço and Figueiras (1995) for the design of RC shell and slab elements subjected to combined membrane and flexural forces. The most significant contribution of this model is that the problem is handled globally, through equilibrium conditions.

In this three-layer model, the middle planes of reinforcement in both directions as well as of concrete are no longer modeled as a unique membrane layer in the outer layers, but as elements working apart, see Figure 2.3. Adopting the usual modeling for RC elements at ultimate state (cracked), reinforcement meshes carry tensile forces while concrete compression layers carry compressive forces, see Figure 2.3(b,c). The tensile forces in the  $x$ - and  $y$ -reinforcement are designed, at the top layer, by  $n_{sxt}$ ,  $n_{syt}$ , and at the bottom layer by  $n_{sxb}$ ,  $n_{syb}$ . Concrete compressive forces, which are developed in compression blocks of concrete and oriented according to compression principal axes, are designated by  $n_{ct}$  (top layer),  $n_{cb}$  (bottom layer).

Figure 2.3(d, c) show the crack patterns of top and bottom layers, whose directions are aligned with the principal axes of concrete compressive forces. As one can see, due to moment forces, the crack patterns at top and bottom generally do not coincide.

This formulation was introduced by Gupta (1986), whom only considered the case wherein reinforcement is needed in both outer layers. Then, Lourenço and Figueiras (1995) extended the formulation to a more general condition, by including three more reinforcement design cases: reinforcement needed only in the bottom layer; reinforcement needed only in the top layer; and no need for reinforcement.

a) Case 1 - Reinforcement Needed in Both Outer Layers

The total resisting forces and moments in the  $x$ - and  $y$ -reinforcement are given by, see Figure 2.3b,

$$n_{sx} = n_{sxt} + n_{sxb} \quad n_{sy} = n_{syt} + n_{syb} \quad (2.7a)$$

$$m_{sx} = n_{sxt} h_{xt} - n_{sxb} h_{xb} \quad m_{sy} = n_{syt} h_{yt} - n_{syb} h_{yb} \quad (2.7b)$$

and in the concrete, see Figure 2.3c, by

$$n_{ct} = -a_t f_c \quad n_{cb} = -a_b f_c \quad (2.8a)$$

$$m_{ct} = \frac{1}{2}(h - a_t)n_{ct} \quad m_{cb} = -\frac{1}{2}(h - a_b)n_{cb} \quad (2.8b)$$

Equations (2.7) to (2.8) give the internal forces and moments. Equilibrium with the applied set of forces and moments yields, see Figure 2.3(a, b, d, e),

$$n_x = n_{sx} + n_{ct} \sin^2 \theta_t + n_{cb} \sin^2 \theta_b \quad (2.9a)$$

$$n_y = n_{sy} + n_{ct} \cos^2 \theta_t + n_{cb} \cos^2 \theta_b \quad (2.9b)$$

$$n_{xy} = -n_{ct} \sin \theta_t \cos \theta_t - n_{cb} \sin \theta_b \cos \theta_b \quad (2.9c)$$

$$m_x = m_{sx} + m_{ct} \sin^2 \theta_t + m_{cb} \sin^2 \theta_b \quad (2.9d)$$

$$m_y = m_{sy} + m_{ct} \cos^2 \theta_t + m_{cb} \cos^2 \theta_b \quad (2.9e)$$

$$m_{xy} = -m_{ct} \sin \theta_t \cos \theta_t - m_{cb} \sin \theta_b \cos \theta_b \quad (2.9f)$$

If  $\theta_t \neq 0, \pi/2$  and  $\theta_b \neq 0, \pi/2$ , equations (2.8a), (2.8b), (2.9c), and (2.9f) give,

$$n_{ct} = -\frac{(h - a_b)n_{xy} + 2m_{xy}}{h_c \sin 2\theta_t} \quad n_{cb} = -\frac{(h - a_t)n_{xy} - 2m_{xy}}{h_c \sin 2\theta_b} \quad (2.10)$$

in which,

$$h_c = h - \frac{(a_t + a_b)}{2} \quad (2.11)$$

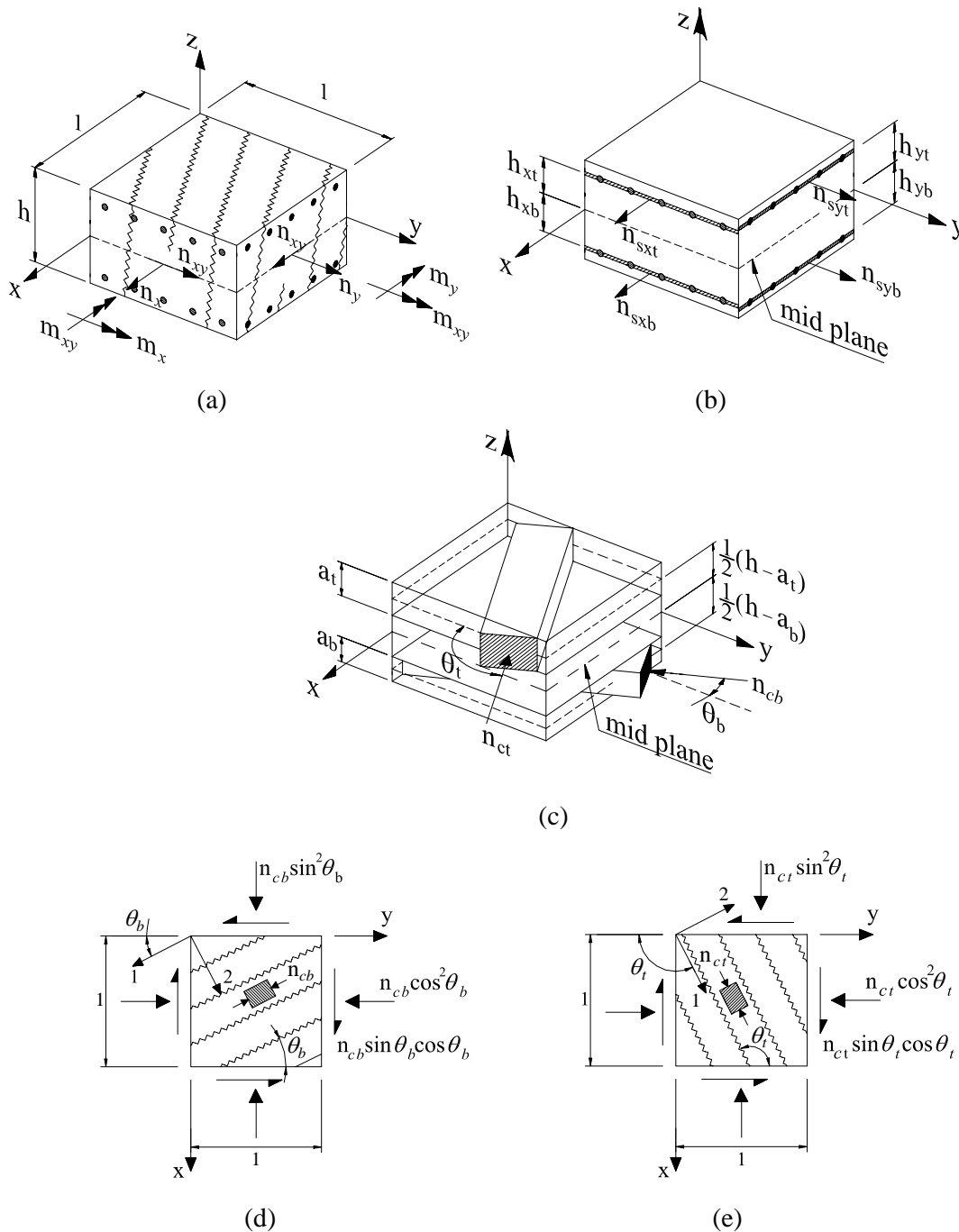

Figure 2.3– Reinforcement in both layers: a) In-plane applied forces; b) steel forces; c) concrete forces; d) top and e) bottom layers with crack directions and concrete forces according to the  $x$  and  $y$  axes.

The reinforcement design will be given upon solving the equilibrium equations (2.9), obtaining thus the values of  $n_{sxt}$ ,  $n_{syt}$ ,  $n_{sxb}$ , and  $n_{syb}$ . The other unknowns are  $a_t$ ,  $a_b$ ,  $\theta_t$ , and  $\theta_b$ . Therefore the system of six equilibrium equations has eight unknowns. This means that the values of  $\theta_t$ ,  $\theta_b$  should be chosen so that the total amount of reinforcement is minimized. As a suggestion, one may assume initial values for  $\theta_t = \theta_{tb} = \pm\pi/4$  and  $a_t = a_b = 0.2h$ . Setting the values of  $\theta$  to  $\pm\pi/4$  is obvious, as this value minimizes the total reinforcement in membrane elements, and setting  $a = 0.2h$  has no special reason but has proven to be efficient.

Using equations (2.7), (2.8), (2.9), (2.10), and (2.11), it is possible to write,

$$n_{sxt} = n_{xt} + n_{xyt} C_{xtt} \tan \theta_t + n_{xyb} C_{xtb} \tan \theta_b \quad (2.12a)$$

$$n_{syt} = n_{yt} + n_{xyt} C_{ytt} \cot \theta_t + n_{xyb} C_{ytb} \cot \theta_b \quad (2.12b)$$

$$n_{sxb} = n_{xb} + n_{xyt} C_{xbt} \tan \theta_t + n_{xyb} C_{xbb} \tan \theta_b \quad (2.12c)$$

$$n_{syb} = n_{yb} + n_{xyt} C_{ybt} \cot \theta_t + n_{xyb} C_{ybb} \cot \theta_b \quad (2.12d)$$

where,

$$n_{xt} = \frac{h_{xb}}{h_x} n_x + \frac{m_x}{h_x} \quad n_{xb} = \frac{h_{xt}}{h_x} n_x - \frac{m_x}{h_x} \quad (2.13a)$$

$$n_{yt} = \frac{h_{yb}}{h_y} n_y + \frac{m_y}{h_y} \quad n_{yb} = \frac{h_{yt}}{h_y} n_y - \frac{m_y}{h_y} \quad (2.13b)$$

$$n_{xyt} = \frac{(h - a_b)n_{xy} + 2m_{xy}}{2h_c} \quad n_{xyb} = \frac{(h - a_t)n_{xy} - 2m_{xy}}{2h_c} \quad (2.13c)$$

and the cross coefficients  $C_{xtt}$ ,  $C_{xtb}$ ,  $C_{ytt}$ ,  $C_{ytb}$ ,  $C_{xbt}$ ,  $C_{xbb}$ ,  $C_{ybt}$ , and  $C_{ybb}$  are defined as

$$C_{xtt} = \frac{h_{xb} + 1/2(h - a_t)}{h_x} \quad C_{xtb} = \frac{h_{xb} - 1/2(h - a_b)}{h_x} \quad (2.14a)$$

$$C_{ytt} = \frac{h_{yb} + 1/2(h - a_t)}{h_y} \quad C_{ytb} = \frac{h_{yb} - 1/2(h - a_b)}{h_y} \quad (2.14b)$$

$$C_{x_{bt}} = \frac{h_{x_t} - 1/2(h - a_t)}{h_x} \quad C_{x_{bb}} = \frac{h_{x_t} + 1/2(h - a_b)}{h_x} \quad (2.14c)$$

$$C_{y_{bt}} = \frac{h_{y_t} - 1/2(h - a_t)}{h_y} \quad C_{y_{bb}} = \frac{h_{y_b} + 1/2(h - a_b)}{h_y} \quad (2.14d)$$

being  $h_x = h_{x_t} + h_{x_b}$  and  $h_y = h_{y_t} + h_{y_b}$ . From equations (2.10) and (2.13), the compressive forces in concrete can be also written as

$$-n_{ct} = \frac{n_{xyt}}{\sin \theta_t \cos \theta_t} \quad -n_{cb} = \frac{n_{xyb}}{\sin \theta_b \cos \theta_b} \quad (2.15)$$

which are similar to the equilibrium equation that relates the shear force  $n_{xy}$  with the compression force  $n_c$  in membrane elements. From equations (2.12) and (2.15), it is possible to write the correspondent applied in-plane forces at reinforcement level in the  $x$  and  $y$  directions, respectively, for the top layer

$$n_{x_t} = n_{s_{xt}} + n_{ct} C_{x_{tt}} \sin^2 \theta_t + n_{cb} C_{x_{tb}} \sin^2 \theta_b \quad (2.16a)$$

$$n_{y_t} = n_{s_{yt}} + n_{ct} C_{y_{tt}} \cos^2 \theta_t + n_{cb} C_{y_{tb}} \cos^2 \theta_b \quad (2.16b)$$

$$n_{xyt} = -n_{ct} \sin \theta_t \cos \theta_t \quad (2.16c)$$

and for bottom layer

$$n_{x_b} = n_{s_{xb}} + n_{ct} C_{x_{bt}} \sin^2 \theta_t + n_{cb} C_{x_{bb}} \sin^2 \theta_b \quad (2.17a)$$

$$n_{y_b} = n_{s_{yb}} + n_{ct} C_{y_{bt}} \cos^2 \theta_t + n_{cb} C_{y_{bb}} \cos^2 \theta_b \quad (2.17b)$$

$$n_{xyb} = -n_{cb} \sin \theta_b \cos \theta_b \quad (2.17c)$$

Through equations (2.12), Gupta (1986) demonstrated that sandwich models with the outer layers modeled as membrane elements yield low reinforcement capacities, showing, therefore, these models are not on the safe side.



Lourenço and Figueiras (1993) have developed and implemented an iterative method to solve the system of equilibrium equations, where the initial values adopted for  $a_t$ ,  $a_b$ ,  $\theta_t$ , and  $\theta_b$  are adjusted iteratively until the equilibrium conditions are established.

In the following the other design cases which have been introduced by Lourenço and Figueiras (1993) are also described.

### b) Case 2 - Reinforcement Needed Only in the Bottom Layer

In this case the top layer is in biaxial compression state and therefore at the bottom layer is reinforcement needed only.

The forces and moments carried by the reinforcement are (see Figure 2.4a),

$$n_{sx} = n_{sxb} \qquad n_{sy} = n_{syb} \qquad (2.18a)$$

$$m_{sx} = -n_{sxb} h_{xb} \qquad m_{sy} = -n_{syb} h_{yb} \qquad (2.18b)$$

and by the concrete bottom layer are (see Figure 2.4b),

$$n_{cb} = -a_b f_c \qquad m_{cb} = -\frac{1}{2}(h - a_b)n_{cb} \qquad (2.19)$$

and at the top layer are assumed to be the forces  $n_{cxt}$ ,  $n_{cyt}$ , and  $n_{cxyt}$ , in the  $x$ - and  $y$ -directions, see Figure 2.4b, and the moments,

$$m_{cxt} = \frac{1}{2}(h - a_t)n_{cxt} \qquad m_{cyt} = \frac{1}{2}(h - a_t)n_{cyt} \qquad m_{cxyt} = \frac{1}{2}(h - a_t)n_{cxyt} \qquad (2.20)$$

Equilibrium with the applied set of forces and moments yields,

$$n_x = n_{sx} + n_{cxt} + n_{cb} \sin^2 \theta_b \qquad (2.21a)$$

$$n_y = n_{sy} + n_{cyt} + n_{cb} \cos^2 \theta_b \qquad (2.21b)$$

$$n_{xy} = n_{cxyt} - n_{cb} \sin \theta_b \cos \theta_b \qquad (2.21c)$$

$$m_x = m_{sx} + m_{cxt} + m_{cb} \sin^2 \theta_b \quad (2.21d)$$

$$m_y = m_{sy} + m_{cyt} + m_{cb} \cos^2 \theta_b \quad (2.21e)$$

$$m_{xy} = m_{cxyt} - m_{cb} \sin \theta_b \cos \theta_b \quad (2.21f)$$

The concrete bottom layer compressive force is equal to the first case, i.e., assuming  $\theta_b \neq 0, \pi/2$  and using equations (2.19), (2.21c), and (2.21f), one gets

$$n_{cb} = -\frac{(h - a_t)n_{xy} - 2m_{xy}}{h_c \sin 2\theta_b} \quad (2.22)$$

For the top layer, which is in a biaxial compression state, the concrete compressive force is given by

$$n_{ct} = -a_t f_c = \frac{n_{cxt} + n_{cyt}}{2} - \sqrt{\left(\frac{n_{cxt} + n_{cyt}}{2}\right)^2 + n_{cxyt}^2} \quad (2.23)$$

The value of  $f_c$  in equation (2.23) has a higher value than the uniaxial compressive strength of cylinders due to biaxial confinement.

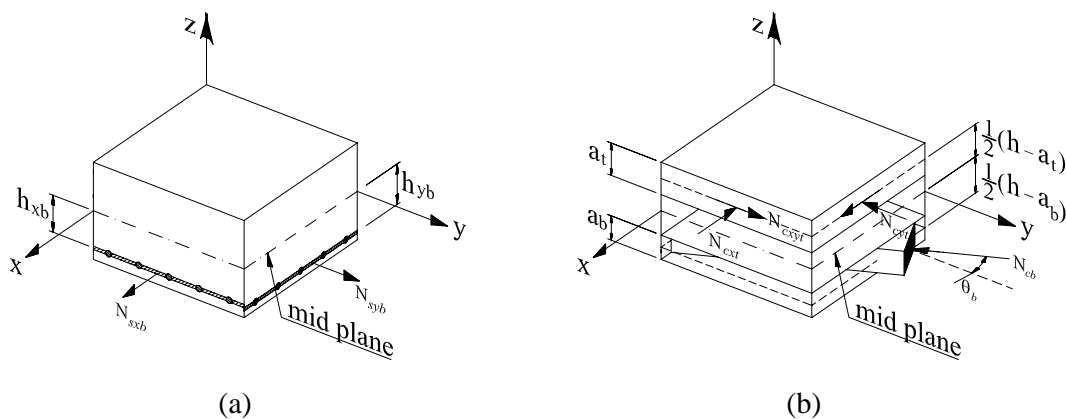

Figure 2.4 – Biaxial compression in the top layer: a) steel forces at bottom layer; b) concrete forces.

In this case, one has also eight unknowns: the forces in the reinforcement to be calculated,  $n_{sxb}$  and  $n_{syb}$ , the concrete top layer forces,  $n_{cxt}$ ,  $n_{cyl}$ , and  $n_{cxyt}$ , as well as the unknowns  $a_t$ ,  $a_b$ , and  $\theta_t$ . However, one extra equation must be added to the six equations of equilibrium (2.21), which is given by equation (2.23). Nevertheless there are eight unknowns and seven equations, meaning that  $\theta_b$  should be chosen so that the total amount of reinforcement is minimized.

As done for the first case, using equations (2.18), (2.19), (2.20), (2.21), and (2.22), it is possible to write for this case the acting forces at the level of bottom reinforcement as follows,

$$n_{sxb} = n_{xb} + n_{xyb} C_{xbb} \tan \theta_b \quad (2.24a)$$

$$n_{syb} = n_{yb} + n_{xyb} C_{ybb} \cot \theta_b \quad (2.24b)$$

However, the new components of membrane forces  $n_{xb}$  and  $n_{yb}$  as well as the new cross coefficients  $C_{xbb}$  and  $C_{ybb}$  in equation (2.24) are defined as

$$n_{xb} = \frac{h - a_t}{2h_x} n_x - \frac{m_x}{h_x} \quad n_{yb} = \frac{h - a_t}{h_y} n_x - \frac{m_y}{h_y} \quad (2.25)$$

$$C_{xbb} = \frac{h_c}{h_x} \quad C_{ybb} = \frac{h_c}{h_y} \quad (2.26)$$

being in this case  $h_x = h_{xb} + (1/2)(h - a_t)$  and  $h_y = h_{yb} + (1/2)(h - a_t)$ .

As one can see from equation (2.24), due to biaxial compression in the top layer, reinforcement design in the bottom layer is quite similar to membrane elements, except for dealing with the effect of different internal lever arms for reinforcement and concrete compression block in the layer. This effect is taken account by the cross coefficients  $C_{xbb}$  and  $C_{ybb}$ .

**c) Case 3 - Reinforcement Needed Only in the Top Layer**

This case is identical to the previous one; therefore the definition of the equilibrium equations requires no additional explanation.

**d) Case 4 – No need for reinforcement**

In this case both the top and bottom layers are in biaxial compression state and the solution of the problem is unique. Assuming that the internal forces in the concrete are, at the top layer,  $n_{cxt}$ ,  $n_{cyl}$ , and  $n_{cxyt}$ , in the  $x$ - and  $y$ -directions, and similarly at the bottom layer,  $n_{cxb}$ ,  $n_{cyb}$ , and  $n_{cxyb}$ , the following equilibrium equations may be written,

$$n_x = n_{cxt} + n_{cxb} \quad (2.27a)$$

$$n_y = n_{cyl} + n_{cyb} \quad (2.27b)$$

$$n_{xy} = n_{cxyt} + n_{cxyb} \quad (2.27c)$$

$$m_x = m_{cxt} + m_{cxb} \quad (2.27d)$$

$$m_y = m_{cyl} + m_{cyb} \quad (2.27e)$$

$$m_{xy} = m_{cxyt} + m_{cxyb} \quad (2.27f)$$

being,

$$\begin{aligned} m_{cxt} &= \frac{1}{2}(h - a_t)n_{cxt} & m_{cyl} &= \frac{1}{2}(h - a_t)n_{cyl} & m_{cxyt} &= \frac{1}{2}(h - a_t)n_{cxyt} \\ m_{cxb} &= -\frac{1}{2}(h - a_b)n_{cxb} & m_{cyb} &= -\frac{1}{2}(h - a_b)n_{cyb} & m_{cxyb} &= -\frac{1}{2}(h - a_b)n_{cxyb} \end{aligned}$$

The concrete compression forces in each layer may be calculated according to equation (2.23). Therefore, there are eight equations for eight unknowns, meaning the solution of the problem is unique, as mentioned before.

### 3 Cracked Three-layer Model

For the analysis and design of cracked, orthogonally reinforced, concrete elements subjected to in-plane forces, Kaufman and Marti (1998) and Kaufmann (2002) have developed a theoretical model called cracked membrane model (CMM). The design equations of the CMM have been recently implemented by Palacio et al. (2003) and incorporated in the DIANA 8.1 finite-element package. In the present work, the concepts of the CMM are extended to the three-layer model of Lourenço and Figueiras (1995), which have been described in the previous section.

The introduction of cracked behavior according to the concepts of the CMM will provide the two-layer model of Lourenço and Figueiras (1995) with constitutive laws and compatibility conditions, resulting in new theoretical model for cracked, orthogonally reinforced shell elements. In addition, the transverse shear forces will be included in the new model by using the concepts of a unified shear-design procedure based on the modified compression field theory, which has been proposed by Adebare and He (1994).

#### 3.1 Cracked Membrane Model

The CMM is a new theoretical model for cracked, orthogonally reinforced, concrete elements subjected to in-plane forces. The model incorporates nonlinear effects as tension stiffening and compression softening, yielding thus a more realistic response for the behavior of membrane elements as have been demonstrated by experimental results, Kaufmann (2002) and Carbone *et al* (2001).

The fundamental issues of the behavior of CMM are based on the concepts of compression field approaches and tension chord model of Marti *et al.* (1998), in which the cracked behavior of membrane elements is formulated considering equilibrium, compatibility, and constitutive laws for concrete and reinforcement. Here, only a brief description of the CMM will be given and the reader is referred to Kaufman and Marti (1998), Kaufmann (2002), and Palacio *et al.* (2003) for a comprehensive review.

- **Equilibrium conditions**

Consider an orthogonally RC membrane element, with a set of parallel, uniformly spaced cracks, see Figure 3.1. Equilibrium of the forces at cracks, requires, see Figure 3.1(b,c),

$$\begin{aligned} n_x &= n_{sx} + n_{ct} \cos^2 \theta + n_{cs} \sin^2 \theta + n_{cst} \sin(2\theta) \\ n_y &= n_{sy} + n_{ct} \sin^2 \theta + n_{cs} \cos^2 \theta - n_{cst} \sin(2\theta) \\ n_{xy} &= (n_{ct} - n_{cs}) \sin \theta \cos \theta - n_{cst} \cos(2\theta) \end{aligned} \quad (3.1)$$

where  $s$  and  $t$  are the coordinates aligned with the crack direction;  $n_{cs}$  and  $n_{ct}$  are the concrete stress normal and parallel to the direction of cracking, respectively, and  $n_{cst}$  is the shear force.

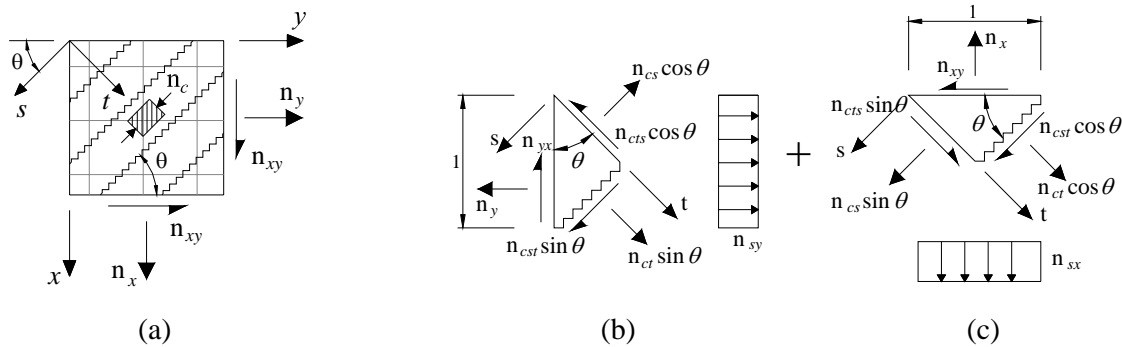

Figure 3.1 – Cracked membrane: a) notation; b) and c) forces at crack.

Applying the basic assumptions of CMM to the equilibrium system, namely (i) crack faces are stress free and able to rotate and (ii) the concrete principal forces and principal strains are coincident, leads to  $n_{cs} = 0$  and  $n_{cst} = 0$ , meaning that equation (3.1) reduces to

$$n_x = n_{sx} + n_c \sin^2 \theta \quad (3.2a)$$

$$n_z = n_{sz} + n_c \cos^2 \theta \quad (3.2b)$$

$$n_{xz} = -n_c \sin \theta \cos \theta \quad (3.2c)$$

where  $n_c = n_{c1} = n_{cs}$  and  $n_{c2} = n_{ct} = 0$ , given the fact that the  $s$  and  $t$  axes are coincident with the major and minor principal stress and strain axes of concrete, respectively.

- **Compatibility of strains**

Due to the fact that cracked concrete is considered as a material with coinciding principal stresses and principal strains axes, which is the essence of the compression field approach, one can determine the state of strain or stress (forces) along any direction through the Mohr's circle. Thus, if the average total membrane strains,  $\varepsilon_x$ ,  $\varepsilon_y$  and  $\gamma_{xy}$ , are known, being  $x$  and  $y$  the orthogonal directions of the reinforcement, the following relationships can be found from the Mohr's circle:

$$\tan \theta = \frac{\varepsilon_y - \varepsilon_1}{\gamma_{xy}/2} \quad (3.3a)$$

$$\cot \theta = \frac{\varepsilon_x - \varepsilon_1}{\gamma_{xy}/2} \quad (3.3b)$$

$$\varepsilon_x + \varepsilon_y = \varepsilon_1 + \varepsilon_2 \quad (3.4)$$

being  $\varepsilon_1$  and  $\varepsilon_2$  the principal average strains. Then, eliminating  $\gamma_{xy}$  in equation (3.3) and associating its result with equation (3.4), one gets,

$$\varepsilon_2 = \varepsilon_y + (\varepsilon_y - \varepsilon_1) \cot^2 \theta \quad (3.5)$$

- **Constitutive Laws**

Steel and bond shear stresses are treated according to Figure 3.2b, where the basic concepts of the tension chord model are extended to cracked membrane elements, see Figure 3.2c. As a result, both reinforcements are treated as tension chords.

For concrete, a parabolic stress-strain relationship is assumed for the principal compressive force  $n_c$  at cracks, whereby compression softening is taken into account, see Kaufmann and Marti (1998), i.e.,

$$n_{c1} = h f_c (\varepsilon_1^2 + 2\varepsilon_1 \varepsilon_{co}) / \varepsilon_{co}^2 \quad (3.6)$$

and

$$f_c = \frac{(f_c')^{2/3}}{0.4 + 30\varepsilon_2} \leq f_c' \text{ in N/mm}^2 \quad (3.7)$$

where  $\varepsilon_{co}$  is the concrete strain at the peak compressive force  $n_{c1}$ ;  $f_c$  is the concrete compressive strength and  $f_c'$  is the cylinder concrete compressive strength.

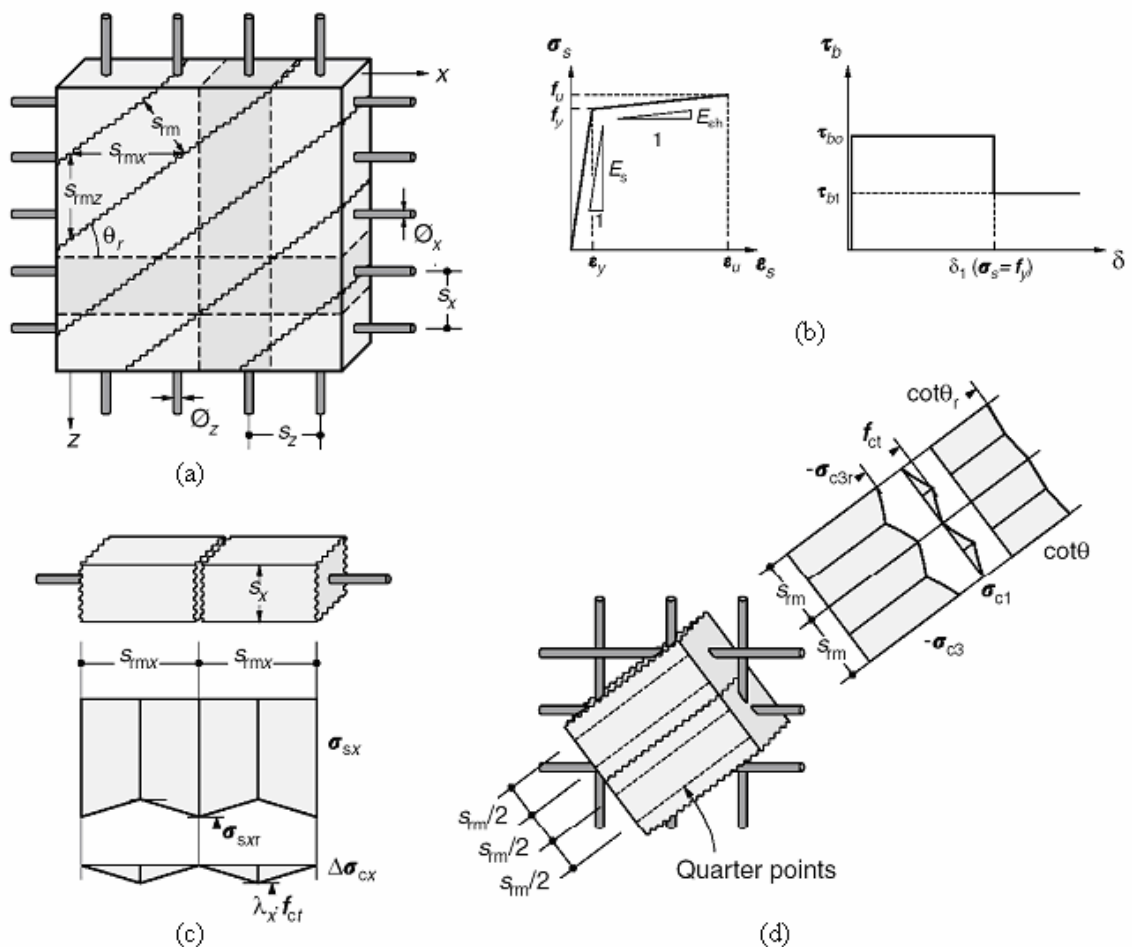

Figure 3.2 – Cracked membrane model: a) notation; b) steel constitutive relationships; c) steel stresses in  $x$ -direction ( $\Delta\sigma_{cx}$  = tension stiffening stress;  $\sigma_{sx} = n_{sx}/h$ ); d) concrete principal stresses ( $\sigma_{c3} = n_c/h$ ).



- **Design equations**

By introducing the assumptions of limit analysis, Kaufmann (2002) obtained expressions to determine the ultimate load of reinforced concrete membrane elements in terms of the reinforcement ratios and the cylinder compressive strength of concrete ( $f_c'$ ).

Yield conditions for RC membrane elements, which are obtained according to the theory of plasticity (limit analysis), allow for a straightforward dimensioning of these elements. The yield criteria in equation (3.8) were first obtained by Nielsen (1964, 1971), using the basic equilibrium equations, equation (3.2).

$$\begin{aligned}
 \Phi_1 &= n_{xy}^2 - (n_{sx} - n_x) \cdot (n_{sy} - n_y) &= 0 \\
 \Phi_2 &= n_{xy}^2 - (n_c - n_{sy} + n_y) \cdot (n_{sy} - n_y) &= 0 \\
 \Phi_3 &= n_{xy}^2 - (n_c - n_{sx} + n_x) \cdot (n_{sx} - n_x) &= 0 \\
 \Phi_4 &= n_{xy}^2 - n_c^2/4 &= 0
 \end{aligned} \tag{3.8}$$

where  $\Phi_1, \Phi_2, \Phi_3$ , and  $\Phi_4$  correspond to the yield regimes 1, 2, 3, and 4, respectively. These regimes describe the following conditions of failure:

Regime 1: both reinforcement yield and concrete suffers no crushing;

Regime 2: concrete crushes and the y-reinforcement remain elastic whereas x-reinforcement, which is weaker, yields;

Regime 3: concrete crushes and the x-reinforcement remain elastic whereas y-reinforcement, which is weaker, yields;

Regime 4: concrete crushes and both reinforcements remain elastic.

Regimes 1, 2 and 3 require reinforcement design. From the yield criteria above, equation (3.8), it is possible to develop the following reinforcement design equations:

- **Regime 1 – both x- and y-reinforcement needed**

$$\begin{aligned}
 n_x &\geq -n_{xy} \tan \theta & n_y &\geq -n_{xy} \cot \theta & -n_c &\geq -hf_c \\
 n_{sx} &= n_x + n_{xy} \tan \theta & n_{sy} &= n_y + n_{xy} \cot \theta \\
 -n_c &= \frac{n_{xy}}{\sin \theta \cos \theta}
 \end{aligned}$$

- Regime 2 - only  $x$ -reinforcement needed

$$n_x \geq -n_{xy} \tan \theta \quad n_y < -n_{xy} \cot \theta \quad -n_c = hf_c$$

$$n_{sx} = n_x + n_{xy} \cot \theta \quad n_{sy} = 0$$

- Regime 3 - only  $y$ -reinforcement needed

$$n_x < -n_{xy} \tan \theta \quad n_y \geq -n_{xy} \cot \theta \quad -n_c = hf_c$$

$$n_{sx} = 0 \quad n_{sy} = n_y + n_{xy} \cot \theta$$

- Regime 4 – no need for reinforcement (biaxial compression)

$$n_x < -n_{xy} \tan \theta \quad n_y < -n_{xy} \cot \theta \quad -n_c \geq -hf_c$$

$$n_{sx} = 0 \quad n_{sy} = 0 \quad -n_c = n_{c1} = \frac{n_x + n_y}{2} - \sqrt{\left(\frac{n_x - n_y}{2}\right)^2 + n_{xy}^2}$$

$$n_{c2} = \frac{n_x + n_y}{2} + \sqrt{\left(\frac{n_x - n_y}{2}\right)^2 + n_{xy}^2}$$

where  $f_c$  is the concrete compressive strength and  $h$  is the membrane thickness.

From the reinforcement design equations described above and equilibrium equations, equation (3.2), it is possible to find the angle  $\theta$  of the principal compression force  $n_c$  with respect the  $y$ -axis for each regime, as follows:

- Regime 1

Associating the equilibrium equations (3.2a),  $n_x - n_{sx} = n_c \sin^2 \theta$ , and (3.2b),

$n_y - n_{sy} = n_c \cos^2 \theta$ , one gets

$$\cot^2 \theta = \frac{n_{sy} - n_y}{n_{sx} - n_x} \quad (3.9a)$$

- Regime 2

Substituting the reinforcement design equation in Regime 2,  $n_{sx} - n_x = n_{xy} \tan \theta$ , with the equilibrium equation (3.2c),  $n_{xy} = -n_c \sin \theta \cos \theta$ , one gets

$$\cot^2 \theta = -\frac{n_c - n_{sx} + n_x}{n_{sx} + n_x} \quad (3.9b)$$

- Regime 3

Substituting the reinforcement design equation in Regime 3,  $n_{sy} - n_y = n_{xy} \cot \theta$ , with the equilibrium equation (3.2c),  $n_{xy} = -n_c \sin \theta \cos \theta$ , one gets

$$\cot^2 \theta = -\frac{n_{sy} - n_y}{n_c - n_{sy} + n_y} \quad (3.9c)$$

- Regime 4

This regime requires  $n_x n_y \geq n_{xy}^2$ , being  $n_x < -n_{xy} \tan \theta$  and  $n_y < -n_{xy} \cot \theta$ , which leads from the Morh's circle to  $\cot^2 \theta = n_{xy} / (n_{c2} - n_x)$ . However, due to the assumptions made by Kaufmann and Marti (1998) to relate the cracked membrane model to limit analysis, as seen right below, considering that strains in the non-yielding reinforcements are equal to  $0.8f_y / E_s \cong 0.002$  in Regime 4, which results from the Morh's circle for strains in

$$\cot^2 \theta = 1 \quad (3.9d)$$

Failure loads obtained from the general numerical method of the cracked membrane model might exceed those obtained from limit analysis, cf. equation (3.8). This is due to the fact that Kauffmann (1998, 2002) has obtained the failure criteria according to limit analysis by assuming the following assumptions. Neglecting strain-hardening for the reinforcement and assuming that the strain in the direction of the non-yielding reinforcement is equal to  $0.8f_y / E_s \cong 0.002$  at ultimate limit, and  $\varepsilon_1 = -\varepsilon_{c0} = 0.002$ , the principal tensile strain  $\varepsilon_1$  in equation (3.5) can be expressed in terms of the reinforcement capacities  $n_{sx}$  and  $n_{sy}$ , by

introducing equation (3.9). Thus, substituting  $\varepsilon_2$  into the expression of concrete compressive strength  $f_c$ , equation (3.7), the resulting new expressions of  $f_c$  for each design regime of membrane elements are obtained,

$$f_{c1} = \frac{(f_c')^{2/3}}{0.46 + 0.12 \cdot \frac{n_{sy} - n_y}{n_{sx} - n_x}} \quad (3.10a)$$

$$f_{c2} = \frac{25}{6} \left( \frac{n_{sx} - n_x}{h} \right) \cdot \left[ \sqrt{\frac{289}{2500} + \frac{12}{25} \cdot \frac{h(f_c')^{2/3}}{n_{sx} - n_x}} - \frac{17}{50} \right] \quad (3.10b)$$

$$f_{c3} = \frac{25}{6} \left( \frac{n_{sy} - n_y}{h} \right) \cdot \left[ \sqrt{\frac{289}{2500} + \frac{12}{25} \cdot \frac{h(f_c')^{2/3}}{n_{sy} - n_y}} - \frac{17}{50} \right] \quad (3.10c)$$

$$f_{c4} = \frac{50}{29} (f_c')^{2/3} \quad (3.10d)$$

where  $f_c'$  is the cylinder concrete compressive strength in N/mm<sup>2</sup> and  $\frac{n_{sy} - n_y}{n_{sx} - n_x} \geq 1$  in equation (3.10a). Finally, substituting the expressions of  $f_c$  into the yield criteria for RC membranes, equation (3.8), the following failure criteria (in terms of forces) for the CMM according to limit analysis is obtained,

$$Y_1 : n_{xy}^2 = (n_{sx} - n_x) \cdot (n_{sy} - n_y) \quad (3.11a)$$

$$Y_2 : n_{xy}^2 = (n_{sx} - n_x)^2 \cdot \left( \sqrt{2 + \frac{25}{3} \cdot \frac{h(f_c')^{2/3}}{n_{sx} - n_x}} - \frac{29}{12} \right) \quad (3.11b)$$

$$Y_3 : n_{xy}^2 = (n_{sy} - n_y)^2 \cdot \left( \sqrt{2 + \frac{25}{3} \cdot \frac{h(f_c')^{2/3}}{n_{sy} - n_y}} - \frac{29}{12} \right) \quad (3.11c)$$

$$Y_4 : n_{xy}^2 = \left[ \frac{25}{29} h(f_c')^{2/3} \right]^2 \quad (3.11d)$$

with  $f'_c$  in N/mm<sup>2</sup>. As one can see, the failure criteria in equation (3.11) are similar to the yield criteria described in equation (3.8). In fact, for Regime 1 both equations are identical and for the other regimes the equations differ only because of the introduction of the expressions of  $f_c$  given in equation (3.10). Therefore, the same design equations of the yield criteria in equation (3.8) can be used. However, the condition of crushing of concrete for all regimes, with relation to the evaluation of the concrete compressive strength, will be given according to equation (3.10). When the principal concrete compression force  $n_{c3}$  is such that the concrete compressive strength in Regime 1,  $f_{c1}$ , is exceeded, i.e. concrete has been crushed, reinforcement design may be carried out in Regime 2 or 3, if  $n_c$  is such that the concrete compressive strength in Regime 4,  $f_{c4}$ , is not surpassed. In such case, the reinforcement to be computed in Regimes 2 or 3 will be given by solving equation (3.11b) or (3.11c).

### **3.2 Cracked Three-layer Model with no Transverse Shear**

The case of combined membrane forces, bending moments and transverse shear is more complex due to the need to deal with triaxial strains and triaxial stresses. However, for practical purposes, the problem of assessing the strains and stresses at ultimate state of cracked shell elements can be solved if the different issues are treated independently.

In the three-layer model of Lourenço and Figueiras (1995) the in-plane forces (membrane forces and bending moments) are modeled acting in two cracked outer layers of thickness  $a_t$  and  $a_b$ . These thicknesses correspond to the thicknesses of compression concrete blocks developed at the top and bottom layers, respectively. Within each cracked layer the resisting forces in the concrete and reinforcement meshes are modeled in their middle planes, whose internal lever positions are not coincident as usually assumed in other sandwich models. From the assumption that each layer has a constant crack pattern through its thickness, it is straightforward to assume a biaxial behavior for the outer layers. Therefore, from such assumption, the concepts of the CMM may be extended to the three-layer model of Lourenço and Figueiras (1995).

### 3.2.1 Introduction of the Concepts of the CMM

Figure 3.3 shows the top and bottom mid planes of concrete compression blocks and the correspondent projection of concrete and steel resisting forces on these planes. Since in both layers reinforcement is required, the biaxial state of forces acting on these layers can be tension in both directions ( $x$  and  $y$  axes) or tension in one direction and compression in the other. Therefore, since reinforcement is assumed to be placed orthogonally, this design case requires at least one reinforcement mesh (placed in  $y$ - or  $x$ -direction) for each layer.

Considering that concrete in both layers has cracked and applied tensile stresses are resisted by reinforcement alone, and assuming that failure of these cracked layers is governed by the yielding of reinforcement, with or without the crushing of concrete, the following design regimes, according to the concepts of limit analysis for membrane elements, may happen to each cracked layer:

- i) both reinforcement yield and concrete suffers no crushing (Regime 1);
- ii) concrete crushes and the  $y$ -reinforcement remains elastic whereas  $x$ -reinforcement, which is weaker, yields (Regime 2) ;
- iii) concrete crushes and the  $x$ -reinforcement remains elastic whereas  $y$ -reinforcement, which is weaker, yields (Regime 3) ;
- iv) concrete crushes and both reinforcement remain elastic.

Thus, combining all the possibilities of failures listed above for both cracked layers, ten design cases can be found:

Case 1 : both layers in Regime 1;

Case 2 : top layer in Regime 1 and bottom layer in Regime 2, or vice-versa;

Case 3 : top layer in Regime 1 and bottom layer in Regime 3, or vice-versa;

Case 4 : top layer in Regime 1 and bottom layer in Regime 4, or vice-versa;

Case 5 : both layers in Regime 2;

Case 6 : top layer in Regime 2 and bottom layer in Regime 3, or vice-versa;

Case 7 : top layer in Regime 2 and bottom layer in Regime 4, or vice-versa;

Case 8 : top layer in Regime 3 and bottom layer in Regime 4, or vice-versa;

Case 9 : both layers in Regime 3;

Case 10 : both layers in Regime 4.

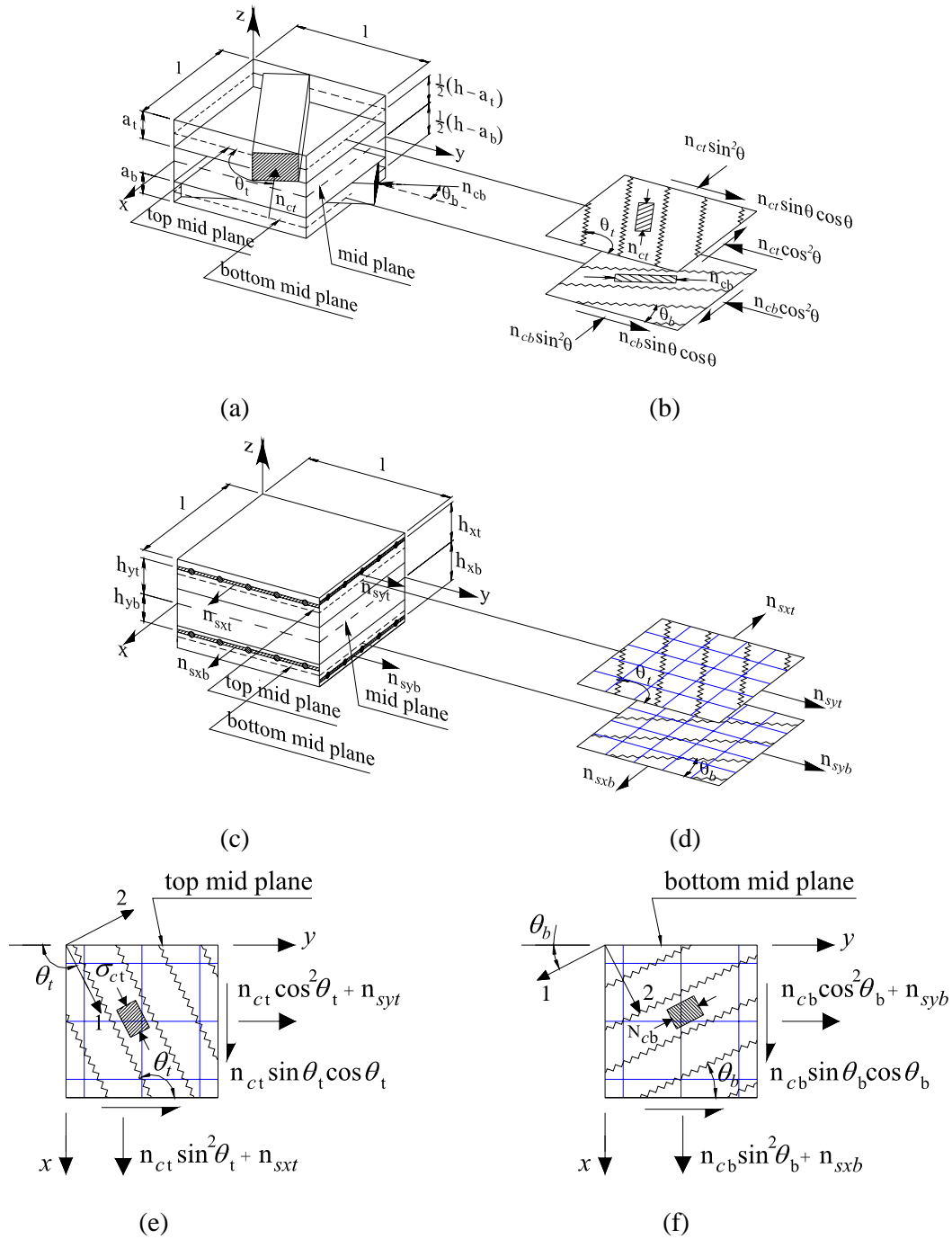

Figure 3.3 – Reinforcement in both layers: a) concrete forces; b) concrete forces projected on the mid plane of outer layers; c) steel forces; d) steel forces projected on the mid plane of outer layers; sum of concrete and steel forces at the e) top and f) bottom layers.

In the following, the design equations for the **top layer** of the cracked sandwich model are developed according to concepts of the CMM and limit analysis. For the bottom layer, such design equations are obtained by exchanging the subscripts  $t$  and  $b$ .

As mentioned before, regimes 1, 2 and 3 require reinforcement design. Reinforcement capacities for the case of reinforcement needed in both layers are given according to equation (2.12). Therefore, from equations (2.12) and (2.10), manipulation according to the design regimes for membrane elements, the following expressions for the **top layer** of the sandwich model are obtained:

- Regime 1 – both  $x$ - and  $y$ -reinforcement needed

$$n_{xt} \geq -(n_{xyt} C_{xtt} \tan \theta_t + n_{xyb} C_{xtb} \tan \theta_b) \longrightarrow n_{sxt} = n_{xt} + n_{xyt} C_{xtt} \tan \theta_t + n_{xyb} C_{xtb} \tan \theta_b$$

$$n_{yt} \geq -(n_{xyt} C_{ytt} \cot \theta_t + n_{xyb} C_{ytb} \cot \theta_b) \longrightarrow n_{syt} = n_{yt} + n_{xyt} C_{ytt} \cot \theta_t + n_{xyb} C_{ytb} \cot \theta_b$$

$$-n_{ct} \geq -hf_{ct}^t \longrightarrow -n_{ct} = \frac{n_{xyt}}{\sin \theta_t \cos \theta_t}$$

- Regime 2 – only  $x$ -reinforcement needed

$$n_{xt} \geq -(n_{xyt} C_{xtt} \tan \theta_t + n_{xyb} C_{xtb} \tan \theta_b) \longrightarrow n_{sxt} = n_{xt} + n_{xyt} C_{xtt} \tan \theta_t + n_{xyb} C_{xtb} \tan \theta_b$$

$$n_{yt} \geq -(n_{xyt} C_{ytt} \cot \theta_t + n_{xyb} C_{ytb} \cot \theta_b) \longrightarrow n_{syt} = 0$$

$$-n_{ct} = a_t f_{c2}^t$$

- Regime 3 – only  $y$ -reinforcement needed

$$n_{xt} \geq -(n_{xyt} C_{xtt} \tan \theta_t + n_{xyb} C_{xtb} \tan \theta_b) \longrightarrow n_{sxt} = 0$$

$$n_{yt} \geq -(n_{xyt} C_{ytt} \cot \theta_t + n_{xyb} C_{ytb} \cot \theta_b) \longrightarrow n_{syt} = n_{yt} + n_{xyt} C_{ytt} \cot \theta_t + n_{xyb} C_{ytb} \cot \theta_b$$

$$-n_{ct} = a_t f_{c3}^t$$

- Regime 4 – no need for reinforcement (biaxial compression)

$$n_{xt} \geq -(n_{xyt} C_{xtt} \tan \theta_t + n_{xyb} C_{xtb} \tan \theta_b) \longrightarrow n_{sxt} = 0$$

$$n_{yt} \geq -(n_{xyt} C_{ytt} \cot \theta_t + n_{xyb} C_{ytb} \cot \theta_b) \longrightarrow n_{syt} = 0$$

$$-n_{ct} \geq -Ka_t f_{c4}^t \longrightarrow -n_{ct} = \frac{n_{cxt} + n_{cyt}}{2} - \sqrt{\left(\frac{n_{cxt} - n_{cyt}}{2}\right)^2 + n_{cxyt}^2}$$



where  $K$  is factor which takes into account the influence of the concrete confinement and it is defined, according to the MC90, CEB-FIP (1991), as

$$K = \frac{1 + 3.65\alpha}{(1 + \alpha)^2}, \text{ with } \alpha = \frac{n_{c1}}{n_{c2}}$$

As done for membrane elements, from the reinforcement design equations described above and equilibrium equations, equation (2.15), it is possible to write the angle  $\theta_i$  of the principal compression force  $n_{ct}$ , with respect to  $y$ -axis for each regime, as follows:

$$\cot^2 \theta_{t1} = \frac{C_{xtt}}{C_{ytt}} \cdot \frac{R_{syt}}{R_{sxt}} \quad (3.12a)$$

$$\cot^2 \theta_{t2} = -\frac{n_{ct} C_{xtt} + R_{sxt}}{R_{sxt}} \quad (3.12b)$$

$$\cot^2 \theta_{t3} = -\frac{R_{syt}}{n_{ct} C_{ytt} + R_{syt}} \quad (3.12c)$$

$$\cot^2 \theta_{t4} = 1 \quad (3.12d)$$

where  $R_{sxt}$  and  $R_{syt}$  are the effective reinforcement forces at the top layer and are given by

$$R_{sxt} = n_{sxt} - n_{xt} - n_{xyb} C_{ztb} \tan \theta_b \quad R_{syt} = n_{syt} - n_{yt} - n_{xyb} C_{ytb} \cot \theta_b \quad (3.13a)$$

for the case of both top and bottom layers to be in a state of tension (uniaxial or biaxial) and

$$R_{sxt} = n_{sxt} - n_{xt} \quad R_{syt} = n_{syt} - n_{yt} \quad (3.13b)$$

for the case of biaxial compression in the bottom layer.

Assuming the same assumptions considered for cracked, orthogonally reinforced, concrete membrane elements, the new expressions of  $f_c$ , from equation (3.7), for the top layer of the cracked sandwich model in each regime are given by

$$f_{c1}^t = \frac{(f_c')^{2/3}}{0.46 + 0.12 \cdot \frac{C_{xtt}}{C_{ytt}} \cdot \frac{R_{syf}}{R_{sxt}}} \quad (3.14a)$$

$$f_{c2}^t = \frac{25}{6} \left( \frac{R_{sxt}}{C_{xtt} a_t} \right) \cdot \left[ \sqrt{\frac{289}{2500} + \frac{12}{25} \cdot \frac{C_{xtt} a_t (f_c')^{2/3}}{R_{sxt}}} - \frac{17}{50} \right] \quad (3.14b)$$

$$f_{c3}^t = \frac{25}{6} \left( \frac{R_{syf}}{C_{ytt} a_t} \right) \cdot \left[ \sqrt{\frac{289}{2500} + \frac{12}{25} \cdot \frac{C_{ytt} a_t (f_c')^{2/3}}{R_{syf}}} - \frac{17}{50} \right] \quad (3.14c)$$

$$f_{c4}^t = \frac{50}{29} (f_c')^{2/3} \quad (3.14d)$$

being  $f_c'$  in N/mm<sup>2</sup> and  $\frac{C_{xtt}}{C_{ytt}} \cdot \frac{R_{syf}}{R_{sxt}} \geq 1$  in equation (3.14a).

### 3.3 Cracked Three-layer Model with Transverse Shear

In the three-layer model of Lourenço and Figueiras (1995) the transverse-shear forces are not considered in the design equations. Thus, in this section, the introduction of the transverse shear forces in the cracked three-layer model forces will be developed by using the concepts of the equivalent beam approach for the shear design of cracked, orthogonally reinforced, concrete shell elements.

The sandwich model of Marti (1991), which has been described in Chapter 2.2, includes the transverse-shear forces by using the concepts of the truss model approach for shear design in beams. Analogous to chords of a truss, the outer layer in this model are assumed to resist membrane forces, bending and twisting moments, while the inner layer resists the transverse-shear forces. After the inner layer is cracked, the transverse shear is resisted by uniaxial diagonal compressive stresses in the concrete (truss model), which must be equilibrated by transverse reinforcement and additional membrane forces in the outer layer. However, this mechanism does not include a concrete contribution and is intended for elements with transverse reinforcement.

By introducing the concepts of the unified shear-design method from Collins et al. (1991) into the sandwich model of Marti (1991), Adebar and He (1994) developed a new

shear-design method. While preserving the simplicity of the truss model and including an appropriate concrete contribution, the new shear-design method can be applied to elements with little or no transverse reinforcement. In the following, only a brief presentation of the method is given and the reader is referred to Adebar and He (1994) for a comprehensive review.

### 3.3.1 Shear-design Method of Adebar and He

In traditional shear-design rules for beams, such as those given in the current edition of the Eurocode 2 (1993), the shear force  $v$  applied to a member is resisted by

$$v = v_s + v_c \quad (3.15)$$

where  $v_c$  is the shear strength provided by residual tensile stresses in the cracked concrete, and  $v_s$  is the shear strength provided by tensile stresses in the stirrups.

According to the truss model for beams, see Figure 3.4, which assumes axial load and bending moment are resisted by the chords of a truss, and shear is resisted by a diagonal compression in the web. The relationship between the applied shear and the required quantity of transverse reinforcement (stirrups) is given by the well-known variable-angle truss-model equation

$$v_s = \frac{A_v f_y}{s} d \cot \theta \quad (3.16)$$

where  $A_v$ ,  $f_y$ , and  $s$  are the cross-sectional area, the yield strength, and the spacing of the stirrups, respectively; and  $\theta$  is the inclination of the diagonal compression. Since the stirrup design is not directly influenced by axial load, a concrete thin surface element subjected to transverse shear can be designed using a truss model in the principal transverse-shear direction. The sandwich model of Marti (1991) has been developed according this approach. As previously mentioned the truss model does not include a concrete contribution and is intended for elements with transverse reinforcement.

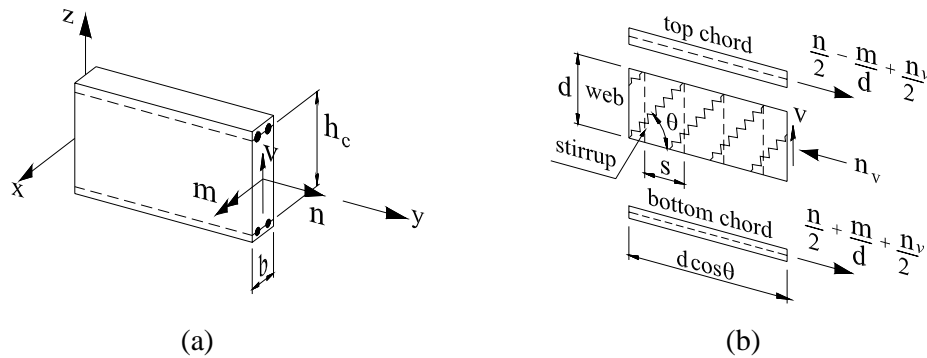

Figure 3.4 – Truss model for beams: a) definition; b) stress resultants acting on web and chords.

The MCFT can be considered a refined truss model that includes a contribution from concrete tensile stresses, and thus can be applied to elements with little or no transverse reinforcement. From the MCFT, Collins and Mitchell (1991) and Collins et al. (1991) have developed a unified shear design method. In this formulation, the stirrup contribution is given according to truss model, equation (3.16), and concrete contribution is assessed by

$$v_c = \beta \sqrt{f'_c} b d \quad (3.17)$$

where the stress factor  $\beta$  and the inclination of the diagonal compression  $\theta$  depend on the shear stress ratio  $\tau/f'_c$  and the longitudinal strain at the level of the flexural reinforcement. Therefore, the value of  $\theta$  in equation (3.16) cannot be freely chosen anymore.

- **Calculation of the normal strain  $\varepsilon_0$**

RC thin surface element subjected to a combination of membrane forces and bending and twisting moments produce biaxial strains in the plane of the outer layers. The assessment of these strains can be a complex issue due to the nonlinearities of concrete. If the reinforcement is not yielding, the tensile stresses in cracked concrete are ignored, and the concrete compressive stresses are in the linear regime. From such considerations, the biaxial-strain components  $\varepsilon_x$  and  $\varepsilon_y$  plus the angle the inclination  $\theta_{xy}$  of the principal compression

force  $n_c$  with respect the  $y$ -axis in an outer layer (with only non-prestressed reinforcement) can be found from the following expressions

$$\varepsilon_x = \frac{n_x + n_{xy} \tan \theta_{xy}}{E_s A_{sx}} \quad \varepsilon_y = \frac{n_y + n_{xy} \cot \theta_{xy}}{E_s A_{sy}} \quad (3.18)$$

$$\left(1 + \frac{E_c}{E_s \rho_y}\right) \cot^4 \theta_{xy} + \frac{n_y}{n_{xy}} \cdot \frac{E_c}{E_s \rho_y} \cot^3 \theta_{xz} - \frac{n_x}{n_{xy}} \cdot \frac{E_c}{E_s \rho_x} \cot^3 \theta_{xz} - \left(1 + \frac{E_c}{E_s \rho_x}\right) = 0 \quad (3.19)$$

where  $E_s$  and  $E_c$  denote the moduli of elasticity of the longitudinal reinforcement and concrete, respectively;  $\rho_x$  and  $\rho_y$  the longitudinal reinforcement ratios in  $x$  and  $y$  directions, respectively. Then the normal strain  $\varepsilon_0$  in the principal transverse shear direction can be determined from the transformation, see Figure 3.5,

$$\varepsilon_0 = \varepsilon_x \cos^2 \alpha_0 + \varepsilon_y \sin^2 \alpha_0 + (\varepsilon_y - \varepsilon_x) \cot 2\theta_{xy} \sin \alpha_0 \cos \alpha_0 \quad (3.20)$$

which must be calculated for both top and bottom layers. The larger value of  $\varepsilon_0$  is used in the design of the transverse reinforcement (stirrups).

- **Design of transverse reinforcement**

Once  $\varepsilon_0$  has been determined, the tensile stress factor  $\beta$  and the inclination of the diagonal compression  $\theta_v$  can be determined from Table 3.1. The values in this table are from the unified shear-design method [Collins and Mitchell (1991)], which is based on the MCFT.

The concrete contribution per unit width of shell element will be

$$v_{c0} = \beta \sqrt{f'_c} h_c \quad (3.21)$$

and the required stirrup contribution is given by

$$v_{s0} = v_0 - v_{c0} \quad (3.22)$$

where  $v_0 = \sqrt{v_x^2 + v_y^2}$  is the principal shear force. Finally, the required area of transverse reinforcement per unit area can be determined from

$$A_{sz} = v_{s0} \frac{\tan \theta_v}{f_{ydz}} \quad (3.23)$$

being  $f_{ydz}$  the design yield strength of stirrups.

If transverse reinforcement is necessary, the in-plane reinforcement in the outer layers must be increased to resist the following additional in-plane forces, see Figure 3.5c,

$$\Delta n_x = (v_{s0} - 2v_{c0}) \cot \theta_v \cos^2 \alpha_0 \quad (3.24a)$$

$$\Delta n_y = (v_{s0} + 2v_{c0}) \cot \theta_v \sin^2 \alpha_0 \quad (3.24b)$$

$$\Delta n_{xy} = (v_{s0} - 2v_{c0}) \cot \theta_v \sin \alpha_0 \cos \alpha_0 \quad (3.24c)$$

Comparative studies on the method with experimental results and numerical results of other more refined and complex shear-design methods, have demonstrated very good agreement, see Adebar and He (1994). From these considerations, the shear-design method proposed by Adebar and He (1994) will be incorporated into the cracked sandwich model to treat the problem of dimensioning the transverse reinforcement. However, due to the introduction of the concepts of the CMM into the proposed sandwich model, the shear-design method will be also modified according to the concepts of CMM.



Table 3.1 – Suggested values of  $\theta_v$  (degree) and  $\beta$  (N/mm<sup>2</sup>) for stirrup design based on MCFT [ adapted from Collins and Mitchell (1991) ]

$v_0/f_c'$	$\theta$ or $\beta$	Normal strain Component in Principal Transverse Shear Direction $\varepsilon_0 \times 1000$														
		0.00	0.25	0.50	0.75	1.00	1.50	2.00	2.50	3.00	5.00	7.00	9.00	11.00	13.00	15.00
$\leq 0.050$	$\theta$	28	31	34	36	38	41	43	45	46	56	56	56	56	56	56
$\leq 0.050$	$\beta$	0.437	0.308	0.251	0.218	0.194	0.163	0.143	0.128	0.116	0.077	0.068	0.058	0.049	0.042	0.037
0.075	$\theta$	28	30	30	34	36	40	42	43	43	56	56	56	56	56	56
0.075	$\beta$	0.405	0.281	0.207	0.198	0.179	0.158	0.138	0.120	0.104	0.077	0.068	0.058	0.048	0.042	0.037
0.100	$\theta$	22	26	30	34	34	36	40	42	43	43	56	56	56	56	56
0.100	$\beta$	0.226	0.202	0.193	0.189	0.173	0.143	0.116	0.097	0.083	0.079	0.068	0.058	0.048	0.041	-
0.125	$\theta$	23	27	31	34	36	36	36	36	36	55	56	56	56	-	-
0.125	$\beta$	0.200	0.194	0.191	0.180	0.167	0.127	0.103	0.086	0.073	0.078	0.068	0.058	0.048	-	-
0.150	$\theta$	25	28	31	34	34	34	34	34	35	55	56	-	-	-	-
0.150	$\beta$	0.211	0.188	0.178	0.172	0.144	0.108	0.087	0.071	0.064	0.078	0.068	-	-	-	-
0.175	$\theta$	26	29	32	32	32	32	34	36	38	54	-	-	-	-	-
0.175	$\beta$	0.195	0.183	0.176	0.14	0.117	0.084	0.078	0.076	0.073	0.96	-	-	-	-	-
0.200	$\theta$	27	30	33	34	34	34	37	39	41	53	-	-	-	-	-
0.200	$\beta$	0.180	0.178	0.174	0.152	0.127	0.090	0.093	0.087	0.083	0.082	-	-	-	-	-
0.225	$\theta$	28	31	34	34	34	37	39	42	44	-	-	-	-	-	-
0.225	$\beta$	0.164	0.173	0.173	0.139	0.113	0.108	0.098	0.097	0.091	-	-	-	-	-	-
0.250	$\theta$	30	32	34	35	36	39	42	45	49	-	-	-	-	-	-
0.250	$\beta$	0.188	0.167	0.156	0.136	0.121	0.114	0.110	0.107	0.103	-	-	-	-	-	-

Note: Combinations of shear  $v_0/f_c'$  and normal strain  $\varepsilon_0$  for which no  $\theta$  and  $\beta$  values are given are not permitted

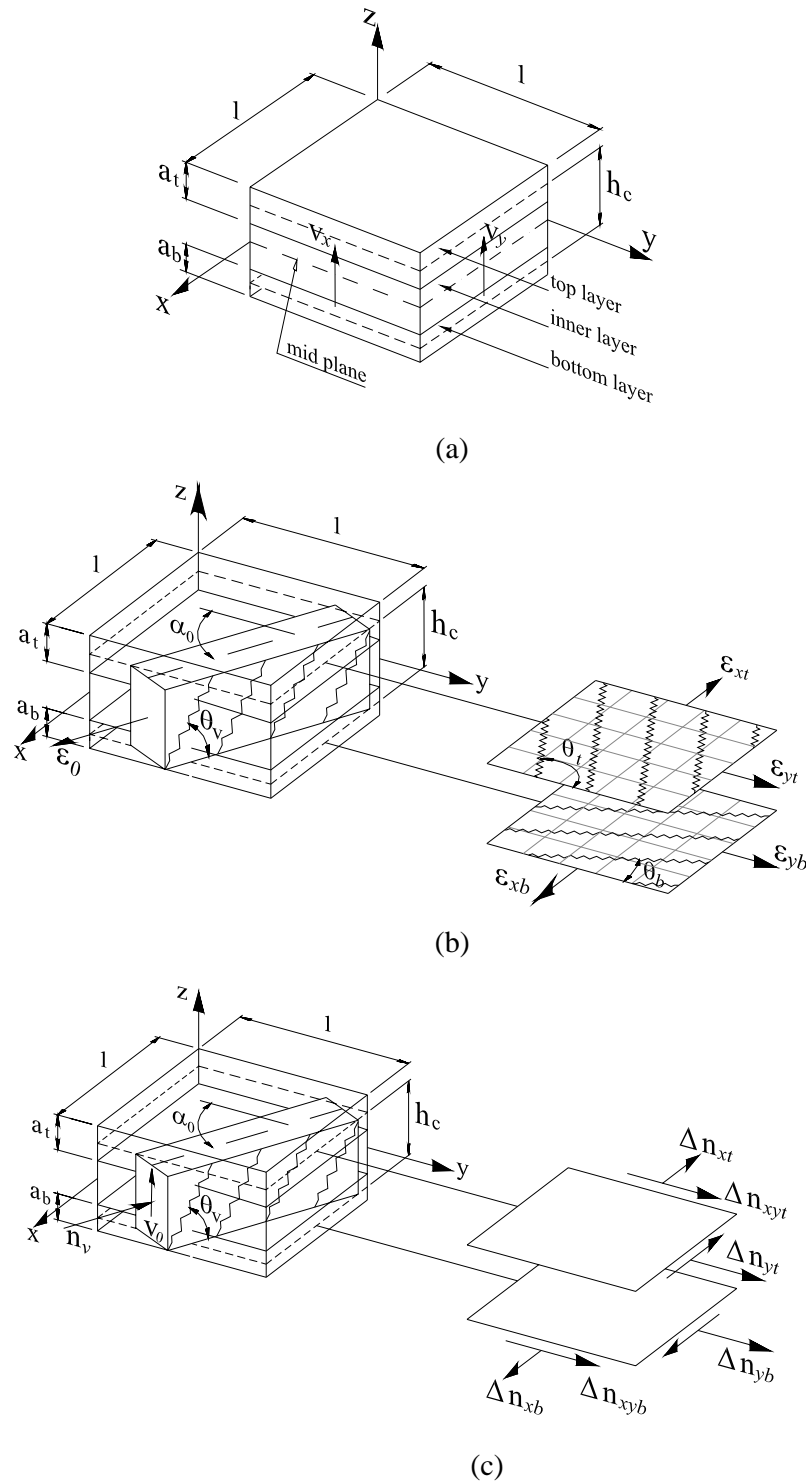

Figure 3.5 – Transverse-shear reinforcement design: a) definition; b) in-plane strains; c) in-plane forces.



### 3.3.2 Introduction of the CMM into the Shear-design Method

By introducing the assumptions of strains at ultimate state for concrete and reinforcement, Kaufmann (1998, 2002) could express the principal tensile strain  $\varepsilon_1$  in the expression of  $f_c$ , equation (3.7), only in term of the inclination  $\theta$  ( $\cot^2 \theta$ ) of the compressive direction, whereby one can relate the value of  $\varepsilon_1$  in terms of the in-plane forces ( $n_x, n_y, n_{sx}, n_{sy}$ ). Therefore, from such relationships, new expressions of  $f_c$  were obtained for each design regime of cracked, orthogonally reinforced, concrete membrane elements. Following this same principle, it is also possible to evaluate the normal strain  $\varepsilon_0$  in the principal transverse shear direction by introducing such assumptions.

The determination of the normal strain  $\varepsilon_0$  in an outer layer is obtained from knowing the strain components  $\varepsilon_x$  and  $\varepsilon_y$  plus the inclination  $\theta_{xy}$  of the compressive direction with respect to the  $y$ -axis in the considered outer layer. Thus, considering that strain in the direction of the yielding and non-yielding reinforcement is equal to  $0.8f_y/E_s \cong 0.002$  at ultimate state, the (tensile) normal strain  $\varepsilon_0$  will be reduced to a single value,  $\varepsilon_0 = 0.004$ , for all the four regimes. Thus, the tensile stress factor  $\beta$  and the inclination of the diagonal compression  $\theta_v$  can be determined from Table 3.1.

As combinations of shear stress  $\nu_0/f_c'$  and normal strain  $\varepsilon_0$  for which no  $\theta_v$  and  $\beta$  values are given are not permitted, the column of  $\varepsilon_0 = 0.003$  will be chosen to evaluate the values of  $\theta_v$  and  $\beta$ .

## 4 Numerical Implementation

This Chapter presents the computer program and the numerical routines developed to implement the reinforcement designs equations for orthogonally reinforced, cracked shell elements, described in the previous Chapter.

Figure 4.1 illustrates the input data window of the computer program, which also performs the reinforcement design for membrane and plate bending structures.

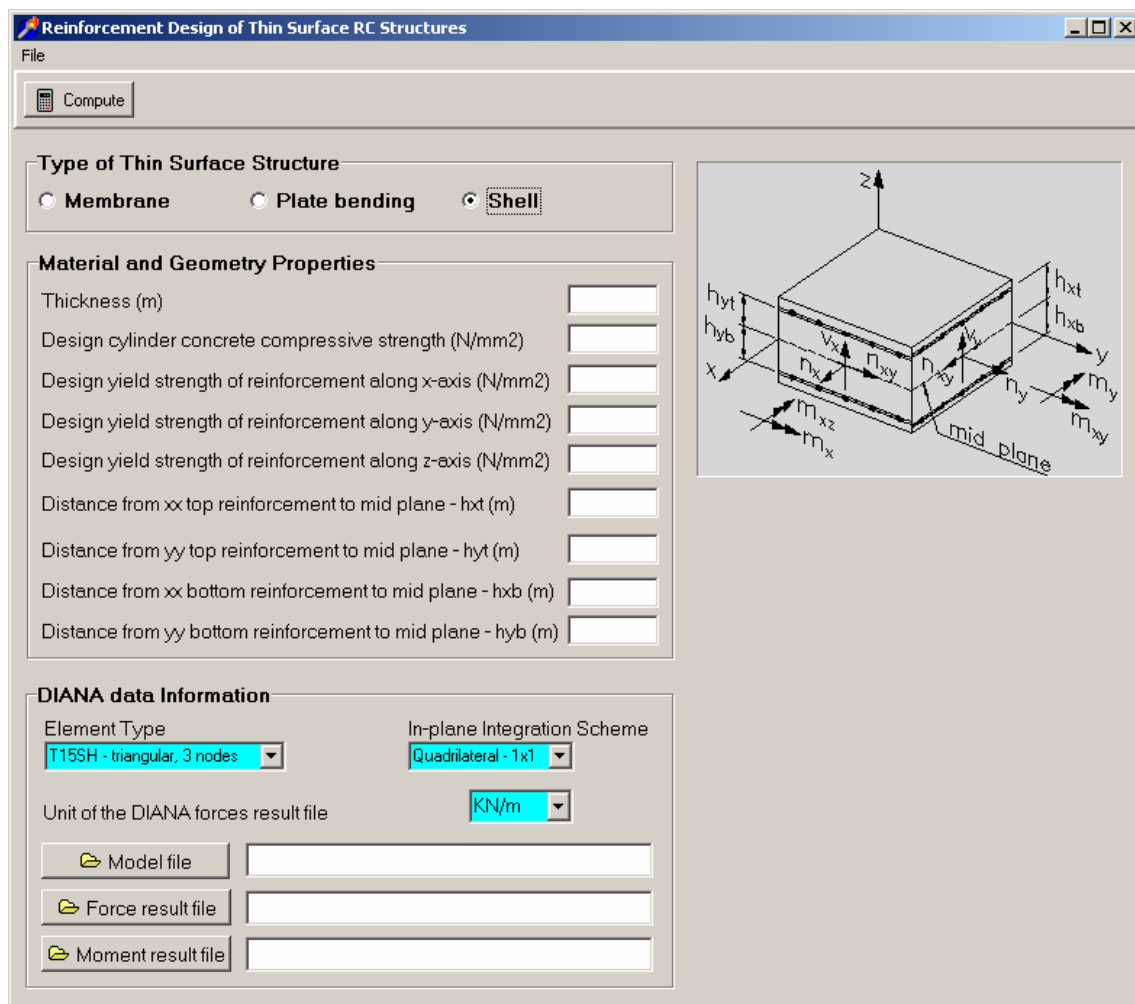

Figure 4.1 – Input data window of the computer program

It can be seen that the input data for the reinforcement design computations is rather simple. In the “Material and Geometry Properties” box, the user inputs the thickness of the

thin surface structure and the vertical distances for the location of the longitudinal reinforcement in the outer layers and material properties of the structure. The input data concerning the location of the longitudinal reinforcement is available for plate bending and shell structures only.

The other box deals with the data provided by DIANA<sup>®</sup> 8.1 finite-element analysis program. From “DIANA Element type” and “In-plane Integration” controls, the user selects the finite-element type and integration scheme which were used for the elastic analysis of the structure in DIANA. Finally, by clicking on “DIANA model file”, “Forces result file”, and “Moment result file” buttons, the user loads the file of the model, and the result files for force and bending moment. The loaded files are text files containing respectively the data of the structure modeled in finite elements for DIANA and the result of obtained from the linear elastic analysis performed in DIANA for the structure.

With the input data completed, the user can process the data by clicking on “Compute” button. Then the following window will be displayed, Figure 4.2, where one can find the reinforcement area results which have been calculated. Besides, the program generates an output file with the results for post-processing in DIANA (neutral file), which can be loaded through the graphical user interface of DIANA from the command UTILITY READ VIEWDATA.

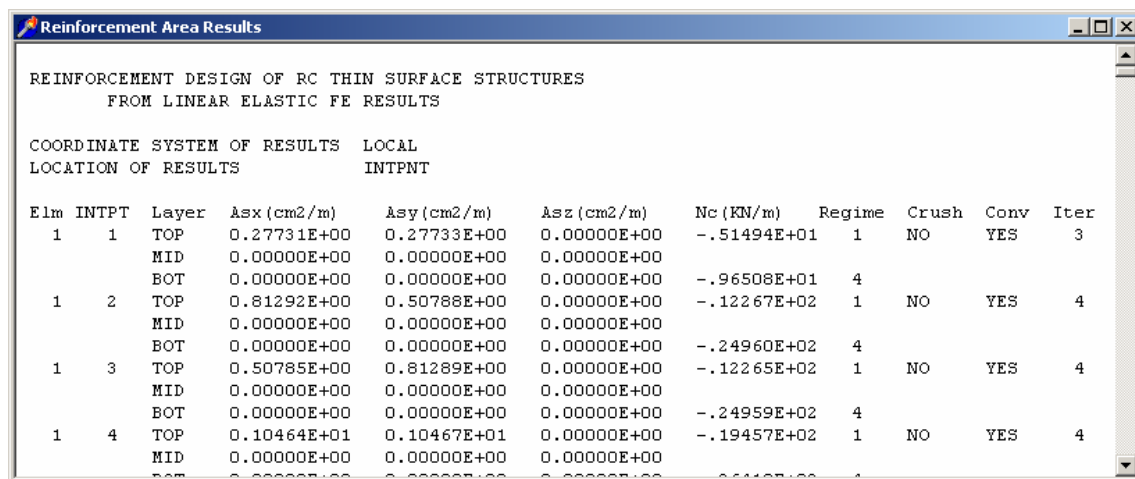

REINFORCEMENT DESIGN OF RC THIN SURFACE STRUCTURES FROM LINEAR ELASTIC FE RESULTS										
COORDINATE SYSTEM OF RESULTS			LOCAL							
LOCATION OF RESULTS			INTPNT							
Elm	INTPNT	Layer	Asx (cm <sup>2</sup> /m)	Asy (cm <sup>2</sup> /m)	Asz (cm <sup>2</sup> /m)	Nc (KN/m)	Regime	Crush	Conv	Iter
1	1	TOP	0.27731E+00	0.27733E+00	0.00000E+00	-.51494E+01	1	NO	YES	3
		MID	0.00000E+00	0.00000E+00	0.00000E+00					
		BOT	0.00000E+00	0.00000E+00	0.00000E+00	-.96508E+01	4			
1	2	TOP	0.81292E+00	0.50788E+00	0.00000E+00	-.12267E+02	1	NO	YES	4
		MID	0.00000E+00	0.00000E+00	0.00000E+00					
		BOT	0.00000E+00	0.00000E+00	0.00000E+00	-.24960E+02	4			
1	3	TOP	0.50785E+00	0.81289E+00	0.00000E+00	-.12265E+02	1	NO	YES	4
		MID	0.00000E+00	0.00000E+00	0.00000E+00					
		BOT	0.00000E+00	0.00000E+00	0.00000E+00	-.24959E+02	4			
1	4	TOP	0.10464E+01	0.10467E+01	0.00000E+00	-.19457E+02	1	NO	YES	4
		MID	0.00000E+00	0.00000E+00	0.00000E+00					
		BOT	0.00000E+00	0.00000E+00	0.00000E+00					

Figure 4.2 – Window of the reinforcement area results

## 4.1 Numerical Routines

The general method based on equilibrium conditions proposed by Lourenco and Figueiras (1995) for the problem of design of longitudinal reinforcement in thin surface concrete elements is solved by an iterative procedure, having the value of compressive strength of concrete  $f_c$  as constant value. In the previous chapter a formulation to assess the value of the  $f_c$  through an experimental expression was introduced. This formulation accounts for the compression softening behavior of concrete as proposed in the CMM of Kaufmann (1998). From the relation to limit analysis for membrane elements, expressions to evaluate the concrete compressive strength for cracked, orthogonally, RC thin surface elements were developed according to each one of the four design regimes of membrane elements. For the first three regimes, the expressions of  $f_c$  depend on the forces applied to reinforcement  $n_{xt}$ ,  $n_{yt}$ ,  $n_{xb}$ , and  $n_{yb}$ . Therefore, the problem exhibits more severe nonlinearity; however, its solution can be also achieved by using the iterative procedure proposed by Lourenço and Figueiras (1993) for the three-layer approach, having as modifications only the introduction of the routine for the computation of  $f_c$ . Thus, the flowchart below presents just the routines for the computation of  $f_c$  and the routine for the three-layer approach can be found in Lourenco and Figueiras (1993).

In addition to the introduction of cracked behavior according to the concepts of CMM, a formulation for the transverse shear design is also included into the three-layer approach according to the concepts of a unified shear-design procedure based on the modified compression field theory. In order to live up to the concepts of the CMM, the unified shear-design procedure has been modified, resulting in a new formulation for the design of transverse reinforcement in cracked, orthogonally, RC thin surface elements. As the new formulation for the shear design does not depend on any unknowns of the formulation for the design of longitudinal reinforcement, it can be solved apart.

The flowchart below presents the numerical routines that were developed to implement the computation of the expression of  $f_c$  according to each design regime and the transverse-shear reinforcement design. For the computation of  $f_c$ , only the expressions for the **top layer** are shown in the flowchart. For the bottom layer, the implementation is very similar and it is obtained by exchanging the subscripts  $t$  and  $b$ .

a) *CMM\_Top* routine

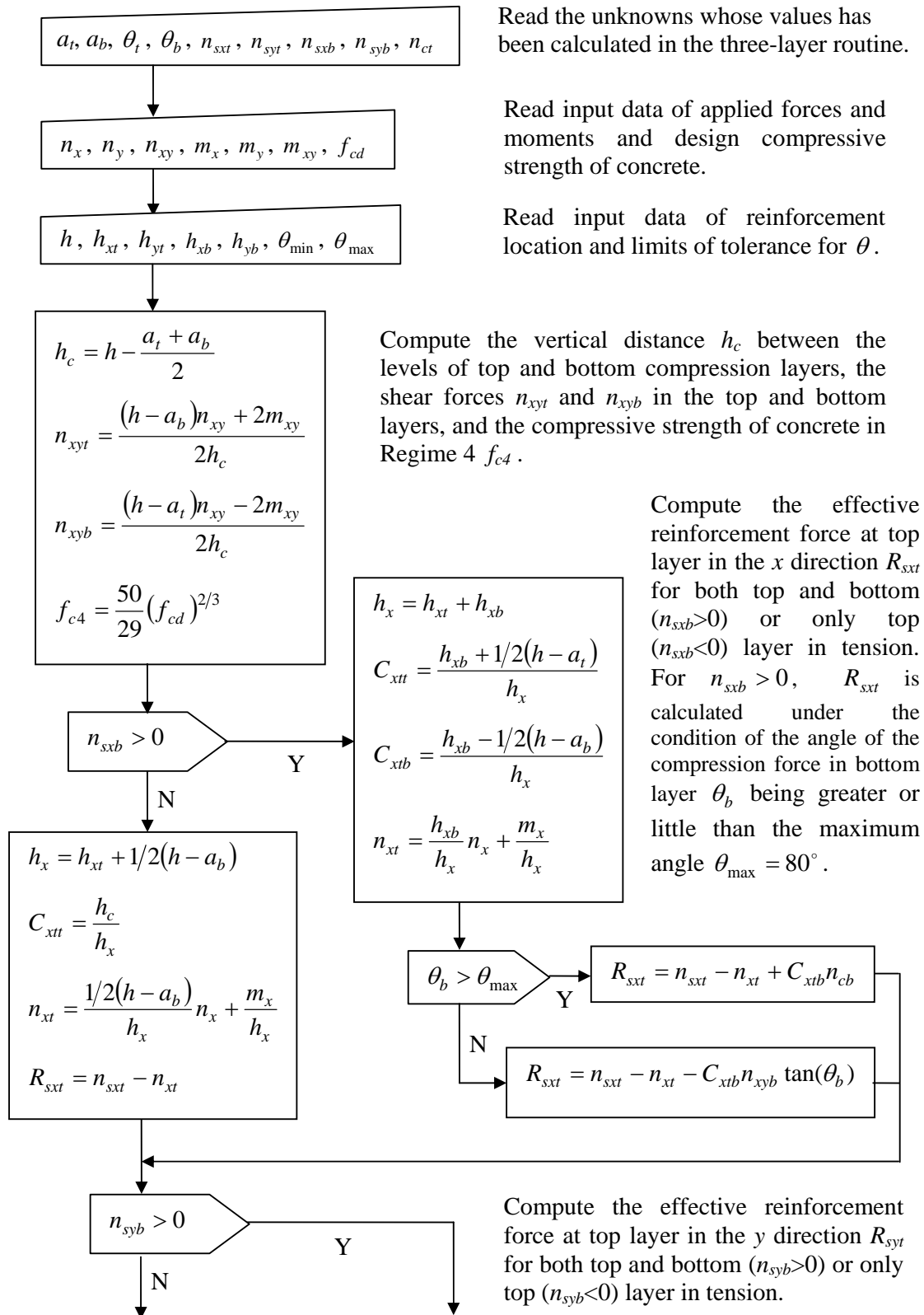

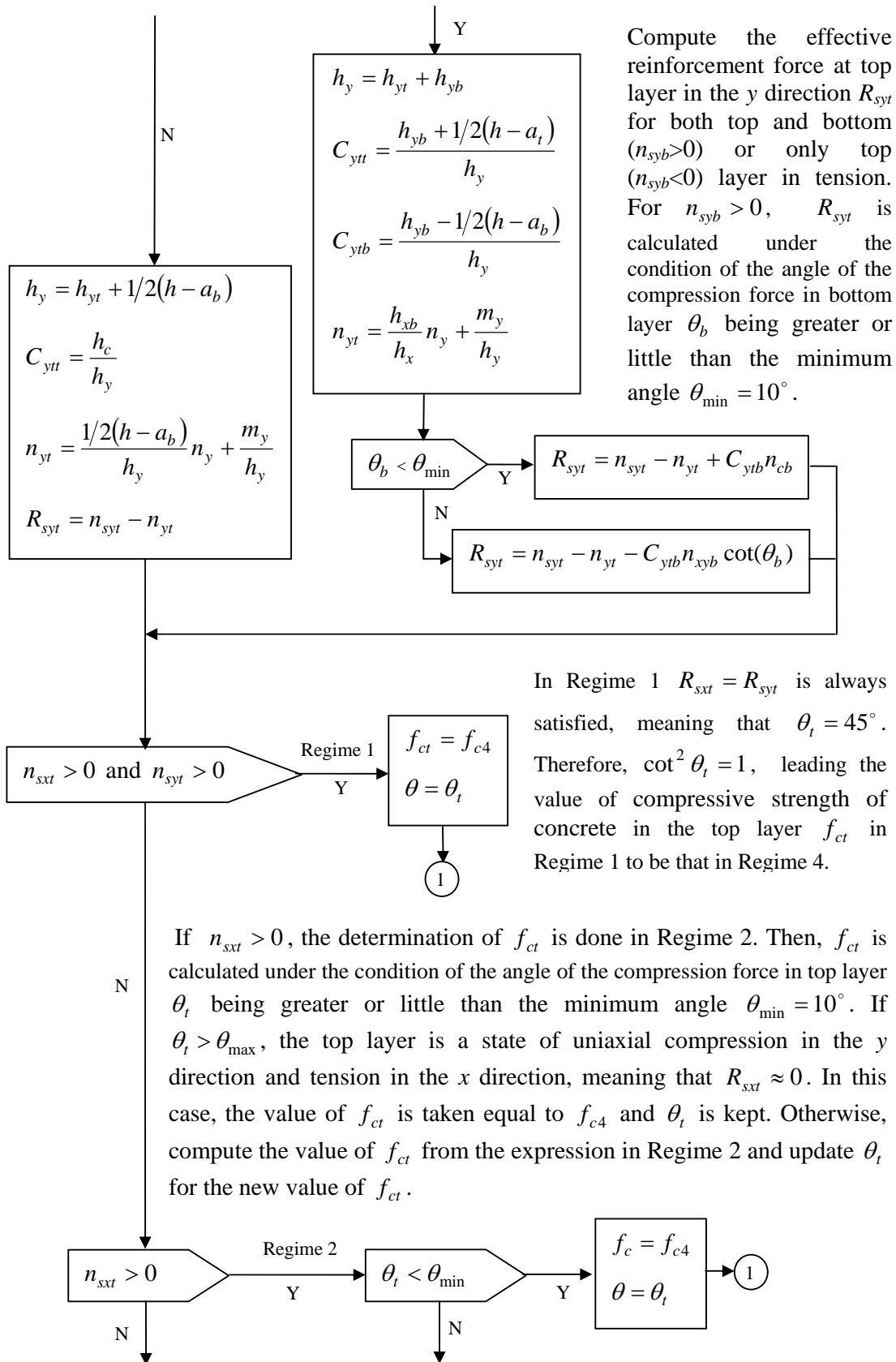

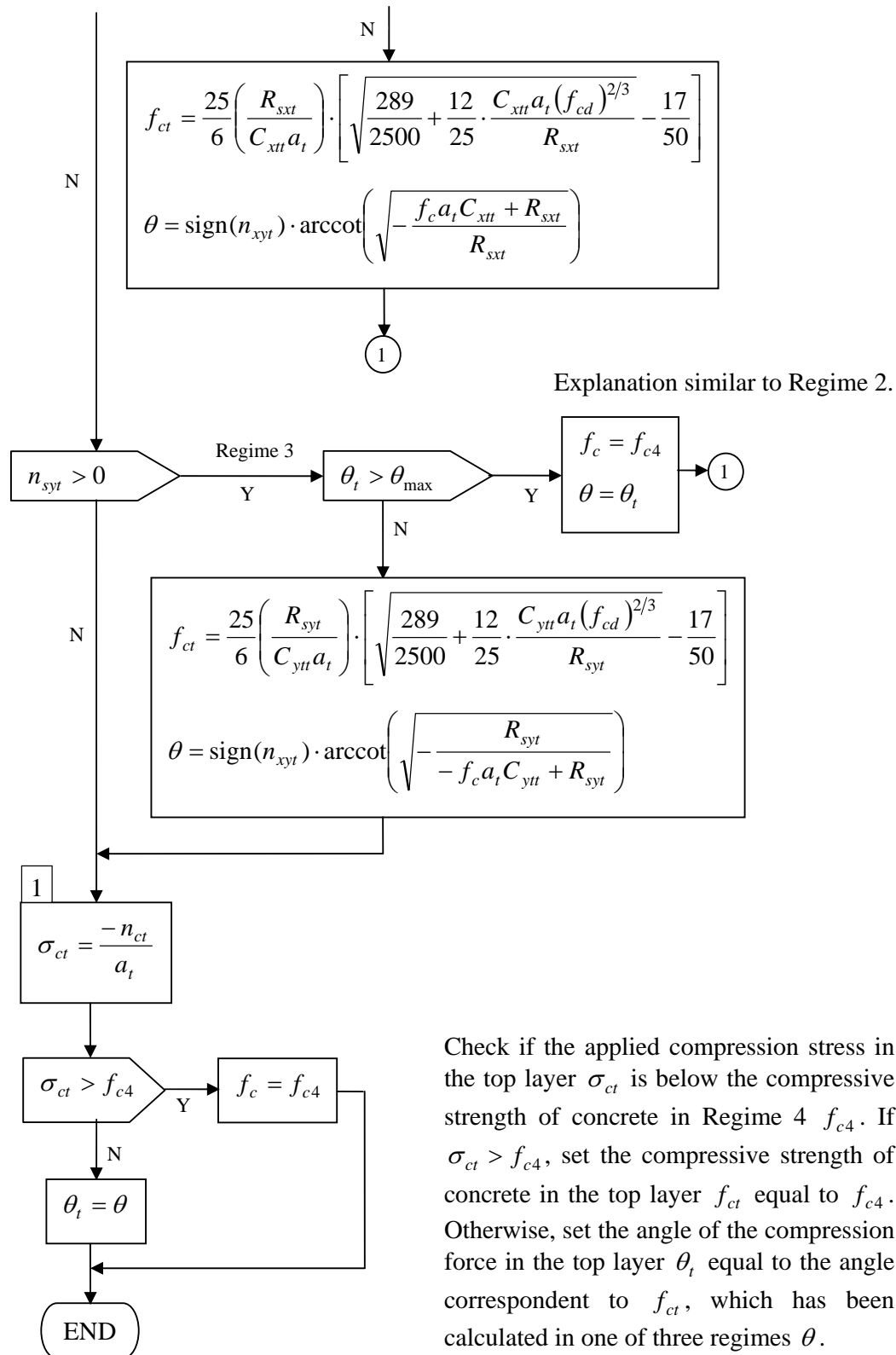

b) *Shear Routine*

The values of  $\beta$  and  $\theta_v$  correspondent to the normal strain  $\varepsilon_0 = 0.003$  and the shear stress level  $r = v/f_{cd}$  in Table 3.1 have been stored into vectors of dimension 9 with the same names of the correspondent parameters.

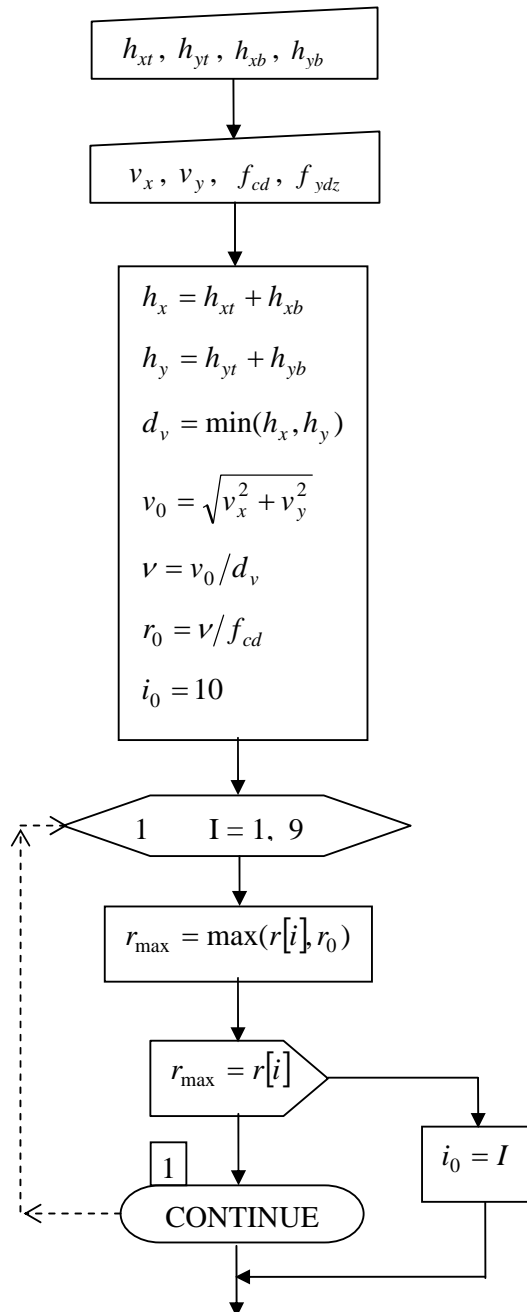

Read input data of reinforcement locations for top and bottom layers.

Read input data of transverse shear forces and design strength of concrete and reinforcement along z direction.

Compute the initial parameters.

Loop to find the upper bound value  $r_0$  in order to determine the index I. This index will give the position of the values  $\beta$  and  $\theta_v$  in Table 3.1.

Check if index  $i_0$  is below the dimension of vector which correspond to number of values stored in the vectors  $\beta$  and  $\theta_v$ .



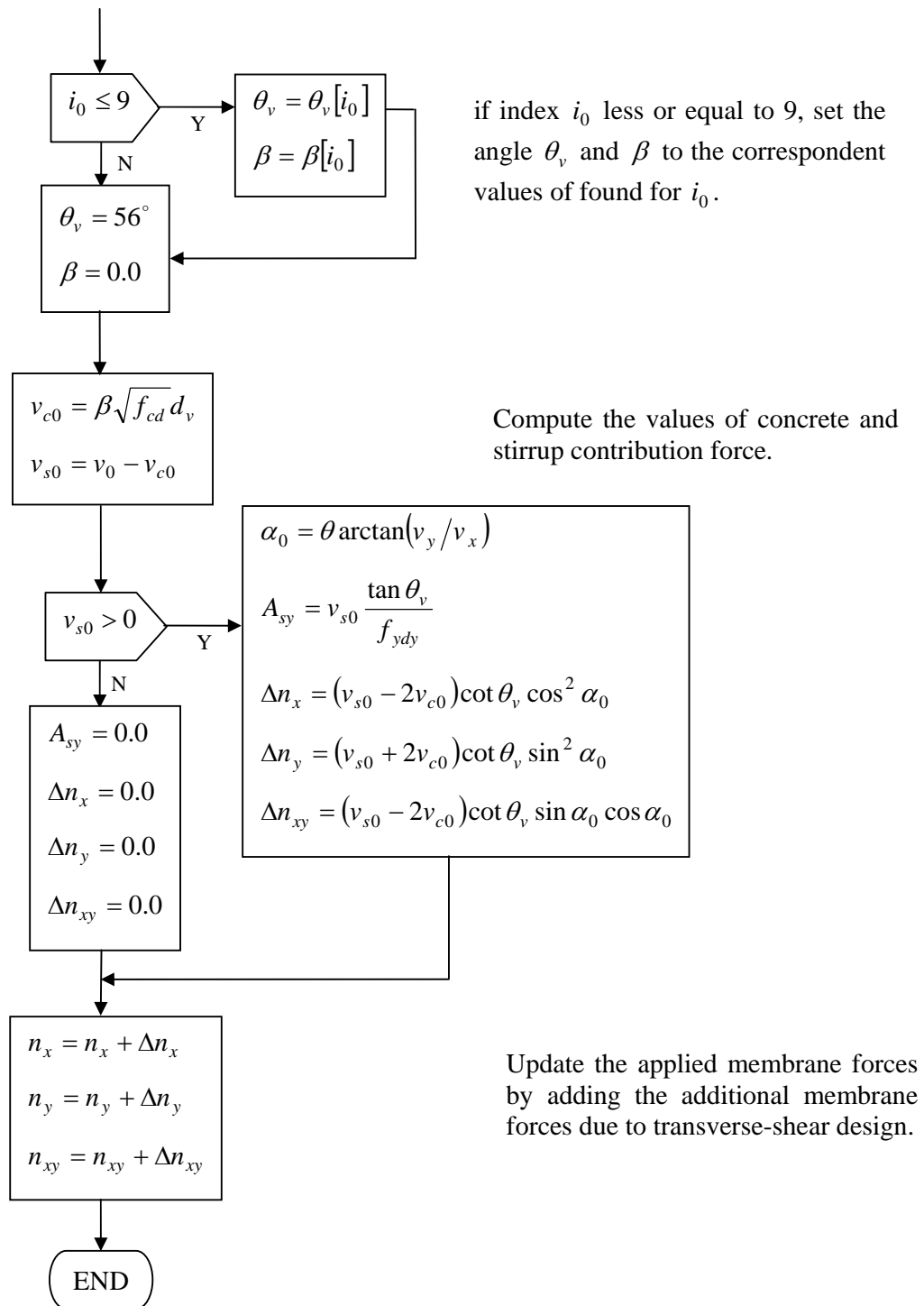

## 5 Validation and Application

This Section will present the validation of the proposed formulation for the reinforcement design of cracked, orthogonally reinforced, concrete thin surface elements as well as one application example using the computer program developed. For the validation, experimental and numerical results by means of nonlinear analysis in single element tests will be compared with the predictions of the proposed model. For the application example, the results obtained from the new sandwich model, the cracked three-layer model, will be compared to those calculated according to the three-layer approach of Lourenco and Figueiras (1993).

The linear elastic analysis, as mentioned before, was performed in DIANA<sup>®</sup> 8.1 finite element program to proceed the reinforcement design in the application example. The results of reinforcement areas computed by the computer program are stored in output files in text format and also in DIANA output format for post-processing in its graphical interface.

### 5.1 Validation 1 - Test ML7 and ML9

A test program on reinforced concrete slabs subjected to torsion was done by Marti and Kong. (1987). Here the test ML7, with a reinforcement ratio of 0.25%, and the test ML9, with a reinforcement ratio of 1%, are presented. Both slabs are 0.20 m thick. In the test 10M rebars were used and in the second test 15M rebars. Figure 5.1 shows the location of reinforcement for both slab element tests.

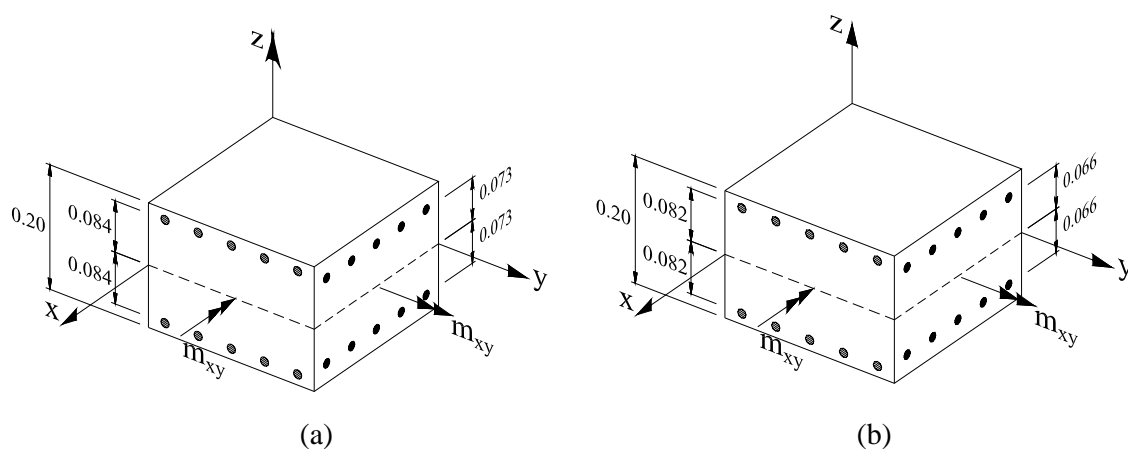

Figure 5.1 – Location of reinforcement: a) Test ML7; b) Test ML9.

With reference to the mechanical properties, the yield stress was  $479 \text{ N/mm}^2$  for the 10M bars and  $412 \text{ N/mm}^2$  for the 15M bars. The compressive strength of concrete measured in cylinders was  $f'_c = 44.4 \text{ N/mm}^2$ . Table 5.1 shows the comparisons between the experimental and those predicted by the proposed method.

Table 5.1 – Reinforcement areas of slab element tests ML7 and ML9.

Test	Ultimate $m_{xy}$ (KN.m/m)	Reinforcement areas ( $\text{cm}^2/\text{m}$ )	
		Experimental	Proposed method
ML7	42.5	5.0	5.0
ML9	101.5	20.0	19.8

As one can see from Table 5.1, the correlation between experimental and numerical is very good in agreement.

## 5.2 Validation 2 - Test Specimen SE7

An experimental facility capable of conducting large-scale tests on reinforced shell elements under a variety of different load combinations was developed at the University of Toronto. Kirsher and Collins (1986) presented the results of a series of such tests. Here only the shell element SE7 will be analyzed. The ultimate load of this 0.285-m-thick specimen was  $n_{xy} = 1806 \text{ KN/m}$  and  $m_x = 235 \text{ KN.m/m}$ . The compressive strength of concrete was  $41.8 \text{ N/mm}^2$ , measured in cylinders. The yield strength of the reinforcement was  $f_{yx} = 492 \text{ N/mm}^2$  and  $f_{yy} = 479 \text{ N/mm}^2$  in the  $x$ - and  $y$ -directions, respectively. Figure 5.2 shows the location of reinforcement in the shell element SE7.

Kolleger (1991) analyzed and designed this element by means of nonlinear analysis, assuming the same type of reinforcement in both directions  $f_{yx} = f_{yy} = 492 \text{ N/mm}^2$ . A load, proportional to the ultimate values observed in the experiment, was then increased until failure. The failure was obtained for 97% of the experimental values. Then, using the same computational code, the specimen was designed for the numerical failure load.

Table 5.3 shows the results obtained by Kolleger (1991) and those obtained with the proposed method. No significant differences are found.

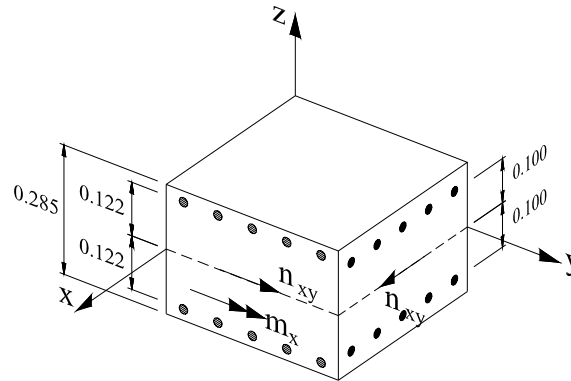

Figure 5.2 – Location of reinforcement in the shell element test SE7

Table 5.2 – Design of shell element (Test specimen SE 7)

Method	Reinforcement areas (cm <sup>2</sup> /m)				
	x-top	y-top	x-bottom	y-bottom	Total
Experimental	41.8	13.9	41.8	13.9	111.4
Nonlinear analysis	37.6	16.9	5.0	14.1	73.6
Proposed method	38.1	18.3	0.0	17.1	73.5

### 5.3 Application Example

A rectangular concrete slab clamped at three edges and the fourth edge free with distributed design load  $p$  of 15 KN/m<sup>2</sup> (including self-weight) is shown in Figure 5.3. The slab has a thickness of 0.15 m and spans of 5 m by 6 m. This example was suggested to demonstrate the capabilities of the three-layer approach of Lourenço and Figueiras (1993).

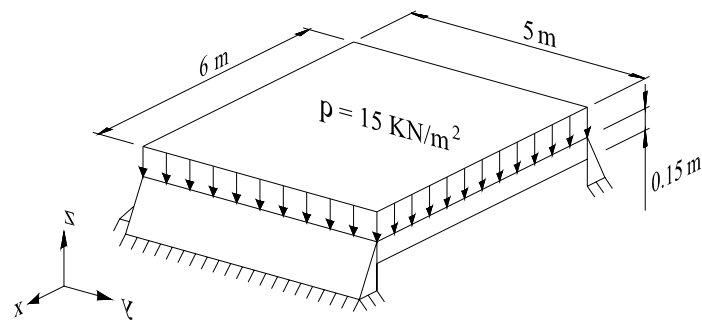

Figure 5.3 – Geometry and loads for simply supported slab

For the linear-elastic FEM analysis, the structure was modeled using eight-node quadrilateral plate bending elements with two by two in-plane Gauss integration. The material properties (concrete) used were 30500 N/mm<sup>2</sup> and 0.2, for Young's modulus and Poisson ratio, respectively. Figure 5.2 shows the graphical presentations for the principal moments.

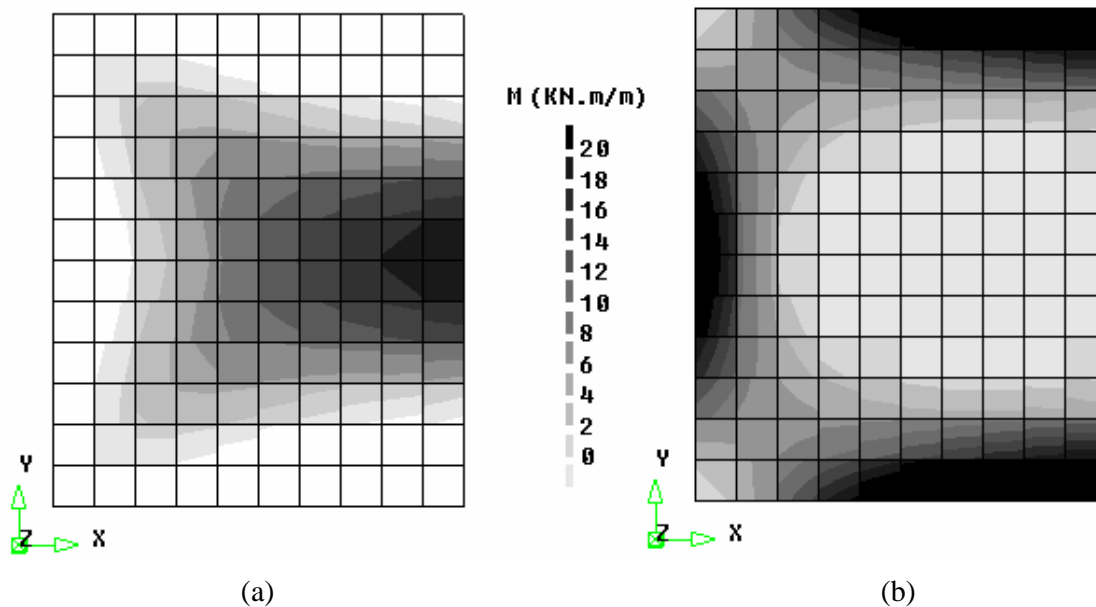

Figure 5.4 – Principal moments results in KN.m/m): a) positive (maximum); b) negative (minimum).

For the reinforcement design in both formulations, a design compressive strength of concrete  $f_{cd} = 13.33 \text{ N/mm}^2$  and a design yield strength of longitudinal and transverse reinforcement  $f_{ydx} = f_{ydy} = f_{ydz} = 347.8 \text{ N/mm}^2$ , were considered.

Finally, Figure 5.5, Figure 5.6 and Figure 5.7 show the graphical representation of reinforcement distribution at the top, bottom, and inner layer respectively, which were calculated according to the cracked three-layer formulation. For the three-layer approach, the graphical representations are not presented because they are quite similar to the cracked three-layer model.

As one can see, according to Table 5.3, the total reinforcement areas for the cracked three-layer model and three-layer approach are very similar. This fact happens because almost all the integration points had combination of forces that fell into regimes 1, see Table 5.4, whereby the value of the compressive strength of concrete  $f_c$  is also kept constant. Due to this fact, just a little increase in the total amount of reinforcement is observed. It could be expected that in cases where more integration points fall in regimes 2 and 3, larger differences are found.

Table 5.3 – Comparison: total reinforcement areas

Formulation	$A_{sxt}$ (cm <sup>2</sup> /m)	$A_{syt}$ (cm <sup>2</sup> /m)	$A_{sxb}$ (cm <sup>2</sup> /m)	$A_{syb}$ (cm <sup>2</sup> /m)	$A_{stot}$ (cm <sup>2</sup> /m)
Three-layer approach	582.29	1004.20	490.75	1024.8	3102.04
Cracked three-layer model	598.81	1120.20	447.33	977.85	3144.19
Differences (%)	2.84	11.55	-8.85	-4.58	1.36

Table 5.4 – Number of design reinforcement carried out in each Regime

Layer	Regimes			
	1	2	3	4
Top	248	4	0	228
Bottom	276	4	4	196

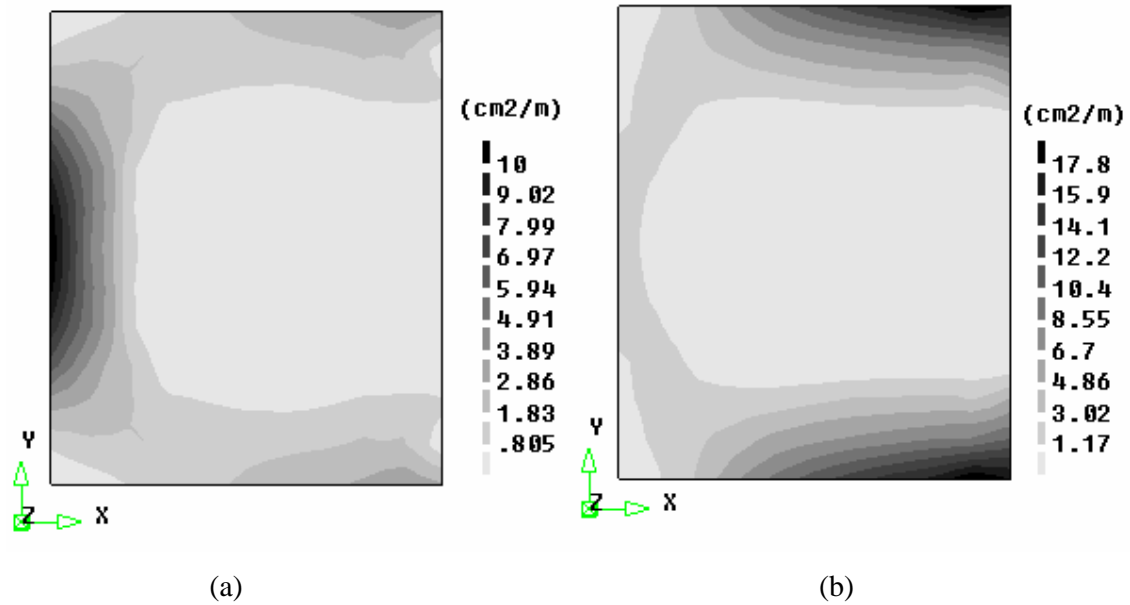

Figure 5.5 – Reinforcement areas at the top layer: a) *x*-direction; b) *y*-direction.

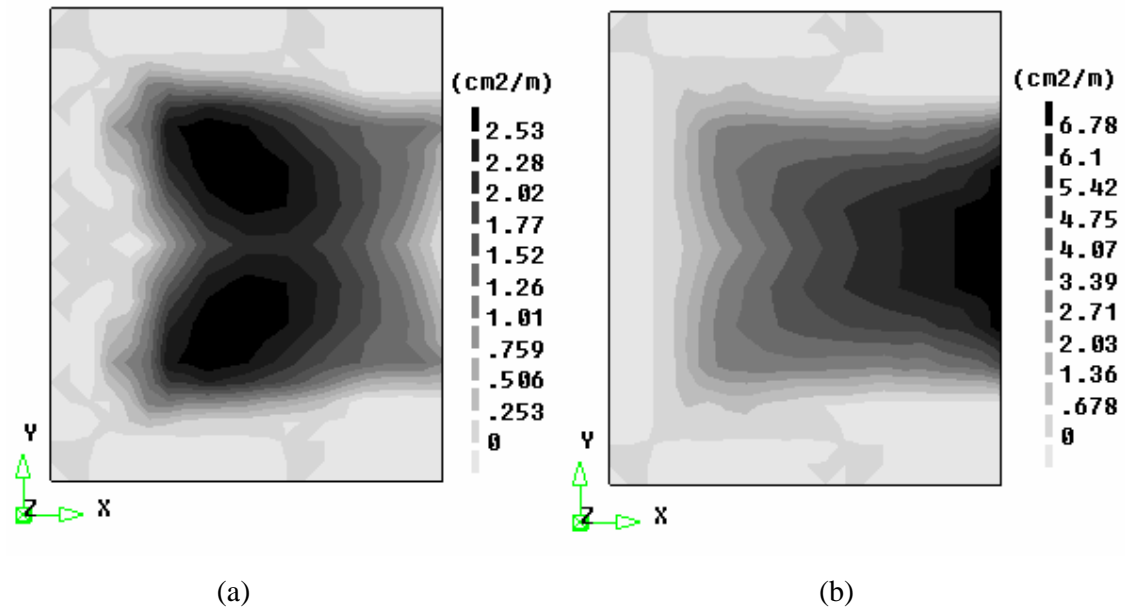

Figure 5.6 – Reinforcement areas at the bottom layer: a) *x*-direction; b) *y*-direction

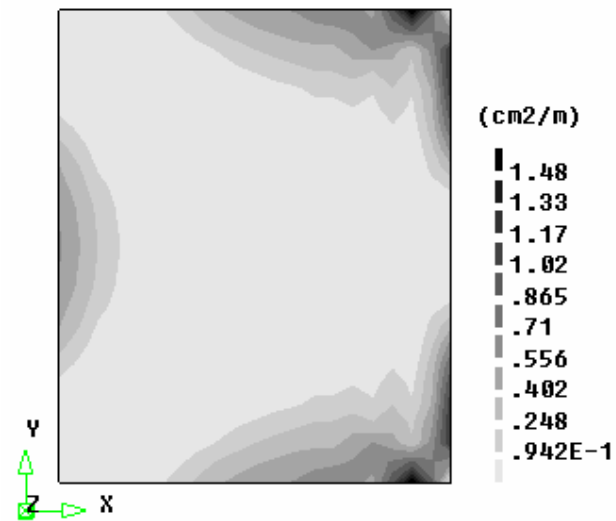

Figure 5.7 – Transverse-shear reinforcement areas



## 6 Conclusions

This report presents the extension of the CMM formulation for cracked, orthogonally reinforced, concrete thin surface elements. The introduction of cracked behavior according to the concepts of the CMM has provided the three-layer approach of Lourenco and Figueiras (1995) with constitutive laws and compatibility conditions, resulting in new theoretical model for cracked, orthogonally reinforced, shell elements. In addition, transverse shear forces have been included in the new model by using the concepts of a unified shear-design procedure based on the modified compression field theory, which has been proposed by Adebar and He (1994).

The new formulation was implemented in a computer program and incorporated in the DIANA 8.1 finite-element package through its post-processing interface, extending the use of finite-element package as also a design tool.

With reference to the validation of the new design model, a good agreement has been found with experimental results. Also, an assessment of the design by means of a nonlinear analysis has proven satisfactory. On the comparisons of the results yielded by the new formulation with the previous one, the three-layer approach, just a minor increase in the total amount of reinforcement has been found. Nevertheless, the new model is more complete and can provide more significant differences in structures with a higher percentage of integration points in regimes 2 and 3, see Palacio *et al.* (2003).

In conclusion, the new formulation seems to be fully comprehensive and adequate for practical design purposes.

## 7 References

ADEBAR, P., HE, W. (1994) – Influence of membrane forces on transverse-shear reinforcement design, *J. Struc. Engrg.*, ASCE, 120 (4), p. 1347-1366.

CARBONE, V.I., GIORDANO, L., MANCINI, G., (2001) – Design of RC membrane elements, *Structural Concrete*, 2001(4), p. 213-223 (2001)

CEB-FIP (1991) - Model Code, Final Draft, Bulletin d'Information n<sup>os</sup> 203, 204 and 205.

COLLINS, M. P., MITCHELL, D. (1991) – *Prestressed Concrete Structures*, Prentice Hall, Englewood Cliffs, N. J.

COLLINS, M. P., VECCHIO, F. J., ADEBAR, P., MITCHELL, D. (1991) – A Consistent Shear Design Model, IABSE report, Zurich, Switzerland, p. 457-462.

GUPTA, A. K. (1986) – Combined Membrane and Flexural Reinforcement in Plates and Shells, *J. Struc. Engrg.*, ASCE, 112 (3), p. 550-557.

KAUFMANN, W. (2002) - Analysis and Design of Structural Concrete Elements Subjected to In-plane Forces, *Structural Concrete*, 2002(3), p. 155-158.

KAUFMANN, W., MARTI, P. (1998) - Structural concrete: cracked membrane model, *J. Struc. Engrg.*, ASCE, 124 (12), p. 1467-1475.

KIRSCHER, U., COLLINS, M. P. (1986) – Investigating the Behavior of Reinforced Concrete Shell Elements, Pub. 86-09, Dept. Civ. Engrg., Univ. of Toronto, Toronto, Ontario.

KOLLEGER, J. (1991) – Computer Programs for Consistent Design of Surface Structures, *Structural Engineering*, IABSE, 62, Stuttgart, Germany, p. 507-512.

LOURENÇO, P.B.; FIGUEIRAS, J.A. (1993) – Automatic design of reinforcement in concrete plates and shells, *Engineering Computations*, 10 (6), p. 519-541.

LOURENÇO, P.B.; FIGUEIRAS, J.A. (1995) – A solution for the design of reinforced concrete plates and shells, *J. Struc. Engrg.*, ASCE, 121(5), p. 815-823.

MARTI, P.; KONG, K. (1987) – Response of Reinforced Concrete Slab Elements to Torsion, *J. Struc. Engrg.*, ASCE, 113 (5), p. 976-993.

MARTI, P. (1990) – Design of Concrete Slabs for Transverse Shear, *ACI Structural Journal*, March-April, p. 180-190.

MARTI, P. (1991) – Dimensioning and Detailing, *Structural Engineering*, IABSE, 62, Stuttgart, Germany, p. 411-443.



MARTI, P.; ALVAREZ, M.; KAUFMANN, W.; SIGRIST, V. (1998) – Tension Chord Model for Structural Concrete, *Structural Engineering, IABSE*, 8, No. 4, p. 287-298.

NIELSEN, M.P. (1964) - Yield conditions for reinforced concrete shells in the membrane state, *Non-classical shell problems*, North-Holland, Amsterdam, p. 1030-1040.

NIELSEN, M.P. (1964a) – Limit Analysis of Reinforced Concrete Slabs, *Acta Polytechnica Scandinavica*, Ci 26, Copenhagen, Denmark.

NIELSEN, M.P. (1971) – On the strength of reinforced concrete disks, *Acta Polytechnica Scandinavica, Civ. Engrg. Constr. Service*, Copenhagen, Denmark.

PALACIO, K.; LOURENÇO, P.B.; BARROS, J.O. – Design of RC elements subjected to in-plane loading, Report 03-DEC/E-30, University of Minho, 45 pp (2003).

VECCHIO, F.J., COLLINS, M.P. (1986) – The modified compression field theory for reinforced concrete elements subjected to shear, *ACI Journal*, 83(2), p. 219-231.