

Single-Phase Shunt Active Filter with Digital Control

J. G. Pinto, Pedro Neves, Ricardo Pregitzer, Luís F. C. Monteiro, João L. Afonso

Industrial Electronics Department
Minho University
Campus de Azurém, 4800-058 Guimarães, Portugal

E-mail: gpinto@dei.uminho.pt, pneves@dei.uminho.pt, rpregitzer@dei.uminho.pt, lmonteiro@dei.uminho.pt,
jlafonso@dei.uminho.pt

Abstract. This paper presents a single-phase shunt active filter designed to minimize problems related to power quality in electrical systems. The power stage of the active filter is based on a two-leg full-bridge inverter, with a single capacitor in the dc side, and a filter inductor in the ac side. The control system is based on the instantaneous power theory in the α - β -0 reference frame (pq-theory), derived to be applied in single-phase systems. In essence, the shunt active filter is designed to drain, from the electric grid, harmonic and reactive components of the load currents, such that the system current will become, basically, a sinusoidal waveform, with low harmonic distortion, and in phase with the system voltage. Simulation results of the shunt active filter operating with three different loads are presented in order to verify its performance.

Key words

Single-Phase Shunt Active Power Filter, Instantaneous Power Theory, Computer Simulations, Power Quality.

1. Introduction

Due to the intensive use of power converters and other non-linear loads, the number and the severity of power quality problems in the electric systems are increasing. Problems like harmonics, inter-harmonics, flicker, notches, sags, swells and others can cause malfunction of equipments based in microelectronic circuits that are very sensible to disturbances in the power supply. In order to minimize the impact of these power quality problems, in 1976 Gyugi and Strycula introduced the concepts of active filters [1].

Active filters, different from the passive ones, have the capability to dynamically adjust to the conditions of the system in terms of harmonics and reactive power compensation. In other words, the shunt active filter drains from the network the distorted components of the load currents, such that the system currents present a waveform with small harmonic distortion, and in phase with the system voltages.

The control strategy applied in this work is based on the definitions for instantaneous power in the α - β -0 reference frame (pq theory), proposed by Akagi *et al.* [2]. In literature, several works can be found on control strategies for active power filters based on instantaneous power theory [3]-[5]. It can also be observed in literature,

works involving control strategies for single-phase shunt active filters [6]-[8].

Fig. 1 presents a shunt active filter in an electric system, in which i_L represents the load current, i_S the system current and i_F represents the shunt active filter compensation current. The measured system voltage corresponds to v_S , and v_{dc} represents the measured voltage at the dc-side of the active filter. The system impedance is represented by L_S , and L_{fp} is the filter inductor used in the output of the active filter. Based on v_S , v_{dc} and i_L the shunt active filter controller generates, in real time, the reference current i_{ref} that will be synthesized by the power inverter. The power inverter is controlled by a periodic-sample switching technique.

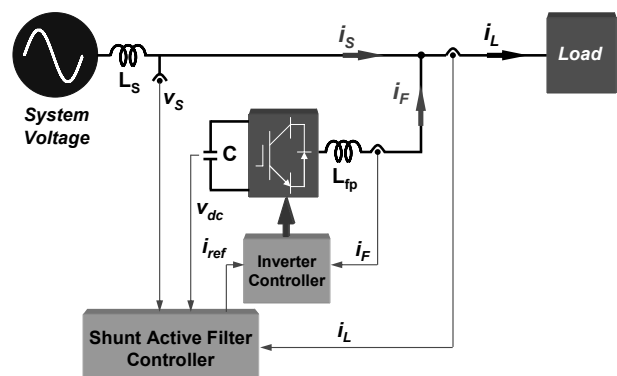

Fig. 1 - Shunt Active Power Filter schematic.

A summary involving the major topics of this paper is described as follows. A set of equations describing the control system based on the instantaneous power theory, and how they are applied to single-phase systems are presented in item 2. Item 3 briefly describes the shunt active filter power circuit. Item 4 presents the shunt active filter performance by means of simulation results developed in PSCAD®/EMTDC™. Finally, conclusions are presented in item 5.

This paper presents simulation results that evaluate the performance of the shunt active filter with three different loads. The first one is represented by a RL circuit, the second load consists in a single-phase diode bridge rectifier with a RL circuit at the dc side, and the third load is represented by a single-phase diode bridge rectifier with a RC circuit at the dc side.

2. Shunt Active Filter Controller

The controller of the shunt active power filter presented in this paper works in the α - β -0 reference frame, and therefore, the system voltages ($v_{S\alpha}$, $v_{S\beta}$, v_{S0}) and the load currents ($i_{L\alpha}$, $i_{L\beta}$, i_{L0}) must be converted to this reference frame by applying the Clarke matrices, shown on equations (1) and (2).

$$\begin{bmatrix} v_{S0} \\ v_{S\alpha} \\ v_{S\beta} \end{bmatrix} = \sqrt{\frac{2}{3}} \cdot \begin{bmatrix} \frac{1}{\sqrt{2}} & \frac{1}{\sqrt{2}} & \frac{1}{\sqrt{2}} \\ 1 & -\frac{1}{2} & -\frac{1}{2} \\ 0 & \frac{\sqrt{3}}{2} & -\frac{\sqrt{3}}{2} \end{bmatrix} \cdot \begin{bmatrix} v_{Sa} \\ v_{Sb} \\ v_{Sc} \end{bmatrix} \quad (1)$$

$$\begin{bmatrix} i_{L0} \\ i_{L\alpha} \\ i_{L\beta} \end{bmatrix} = \sqrt{\frac{2}{3}} \cdot \begin{bmatrix} \frac{1}{\sqrt{2}} & \frac{1}{\sqrt{2}} & \frac{1}{\sqrt{2}} \\ 1 & -\frac{1}{2} & -\frac{1}{2} \\ 0 & \frac{\sqrt{3}}{2} & -\frac{\sqrt{3}}{2} \end{bmatrix} \cdot \begin{bmatrix} i_{La} \\ i_{Lb} \\ i_{Lc} \end{bmatrix} \quad (2)$$

The original theory of instantaneous reactive power is only applicable to three-phase systems. The strategy used to apply this theory to a single-phase system consists in creating two virtual currents and two virtual voltages that have the same magnitude as the measured current and voltage, but are shifted $\pm 120^\circ$ to perform a virtual three-phase system. After this operation the methodology is the same as applied in real three-phase systems. At the end of the calculations only one of the three reference currents is used to control the inverter.

After the transformation, the p-q theory components are calculated using the expressions (3-4), where p is the instantaneous real power, and q is the instantaneous imaginary power (by definition).

$$p = v_{S\alpha} \cdot i_{L\alpha} + v_{S\beta} \cdot i_{L\beta} \quad (3)$$

$$q = v_{S\beta} \cdot i_{L\alpha} - v_{S\alpha} \cdot i_{L\beta} \quad (4)$$

Normally only the average value of the instantaneous real power (\bar{p}) is desirable and the other power components can be compensated using a shunt active filter. In order to calculate the reference currents that the active filter should inject it is necessary to separate the desired power components from the undesired ones. The undesired power components are denominated p_x and q_x .

In addition to the instantaneous power components defined by the p-q Theory, there is also a component, p_{reg} , which is used to regulate the capacitor voltage in the dc side of the Shunt Active Power Filter. This regulation is done with a proportional controller and the error between the reference voltage (V_{ref}) and the voltage measured at the dc side of the inverter (v_{dc}).

$$p_{reg} = k_p (V_{ref} - v_{dc}) \quad (5)$$

The component p_{reg} is included in the value of p_x . Therefore, the values of the undesired power components are given by:

$$p_x = (p - \bar{p}) - p_{reg} = \tilde{p} - p_{reg} \quad (6)$$

$$q_x = q \quad (7)$$

The undesired power components are used to determine the compensation currents in the α - β coordinates by the expressions (8). The compensation current in the 0 coordinate is obtained directly from load currents by expression (9).

$$\begin{bmatrix} i_{ref_a} \\ i_{ref_b} \end{bmatrix} = \frac{1}{v_\alpha^2 + v_\beta^2} \cdot \begin{bmatrix} v_\alpha & v_\beta \\ -v_\beta & v_\alpha \end{bmatrix} \cdot \begin{bmatrix} p_x \\ q_x \end{bmatrix} \quad (8)$$

$$i_{ref_0} = i_{L0} = \frac{1}{\sqrt{3}} \cdot (i_{La} + i_{Lb} + i_{Lc}) \quad (9)$$

The reference compensation currents in the a - b - c coordinates (i_{ref_a} , i_{ref_b} , i_{ref_c}) are determined by applying the inverse Clarke transformation to the currents in the α - β -0 coordinates, as demonstrated in expression (10).

$$\begin{bmatrix} i_{ref_a} \\ i_{ref_b} \\ i_{ref_c} \end{bmatrix} = \sqrt{\frac{2}{3}} \cdot \begin{bmatrix} \frac{1}{\sqrt{2}} & 1 & 0 \\ \frac{1}{\sqrt{2}} & -\frac{1}{2} & \frac{\sqrt{3}}{2} \\ \frac{1}{\sqrt{2}} & -\frac{1}{2} & -\frac{\sqrt{3}}{2} \end{bmatrix} \cdot \begin{bmatrix} i_{ref_0} \\ i_{ref_a} \\ i_{ref_b} \end{bmatrix} \quad (10)$$

Fig. 2 illustrates the shunt active filter controller in the form of a block diagram.

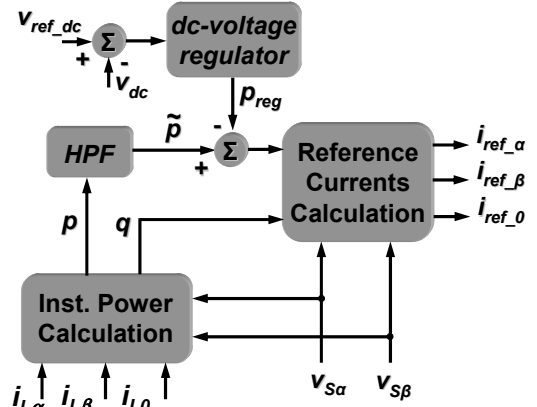

Fig. 2 – Active filter controller block diagram.

3. Shunt Active Filter Power Circuit

The power circuit of the Single-Phase Shunt Active Filter is constituted by a two-leg, 4 IGBTs (with antiparallel diodes) Voltage Source Inverter (VSI). The dc side of the inverter uses a single capacitor (with 4.7 mF capacitance), and between the inverter and the point of connection to the electric grid is used a filter inductor (with 5 mH inductance) to reduce the ripple, caused by the inverter switching, in the compensation current produced by the shunt active filter.

The switching control of the IGBTs of the inverter has been done with Periodic Sampling technique [9], which is a very simple technique, but that does not work with a fixed switching frequency, although establishes an upper frequency limit, which in this work was set to 15 kHz.

4. Simulation Results

This item shows simulation results for the Single-Phase Shunt Active Filter, working with Periodic Sampling switching technique, for three different types of loads: linear RL load, single-phase full bridge rectifier with a series RL load, and single-phase full bridge rectifier with a parallel RC load. For each load it is presented the voltage system (v_s) and the source current (i_s), first with the shunt active filter turned off, and then with the active filter turned on. With the shunt active filter operating, it is also shown the compensation current produced by the active filter (i_f) and its reference current (i_{ref}), that corresponds to the compensation current calculated by the digital control system of the active filter. For each load it is also shown the behavior of the voltage system, source current, and active filter dc side voltage when the shunt active filter is turned on (transient operation).

A. RL Load

This load (denominated load A) consists of a 31 mH inductor with 0.7Ω resistance. Figures 3 to 7 show waveforms obtained from simulation results performed with this type of load. Fig. 3 presents the system voltage (v_s) and the source current (i_s) before the shunt active filter starts its operation. Fig. 4 illustrates the same waveforms after the connection of the active filter to the electric system. Fig. 5 presents the reference current (i_{ref}) and the compensation current (i_f) of the active filter. It is important to comment that in figures 3, 4 and 5 the aforementioned waveforms are observed with the power system in steady-state. Fig. 6 presents the system voltage (v_s) and the source current (i_s) when the shunt active filter is connected to the power system (transient operation). Fig. 7 illustrates the dc side voltage (v_{dc}) also when the shunt active filter is connected to the power system (transient operation).

From these simulation results it is possible to conclude that, for this type of load the shunt active filter corrects successfully the power factor, and ought to that, the current source value decreases considerably.

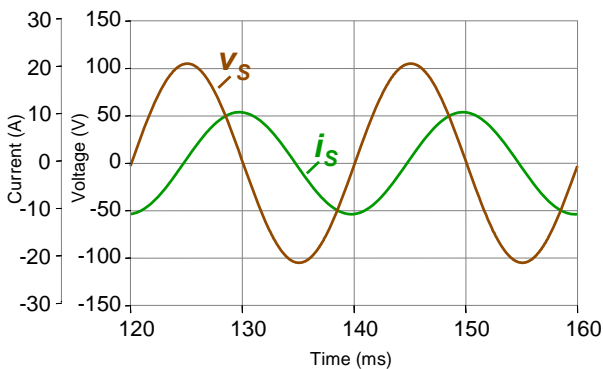

Fig. 3 – Load A: System voltage (v_s) and source current (i_s) before the shunt active filter starts its operation.

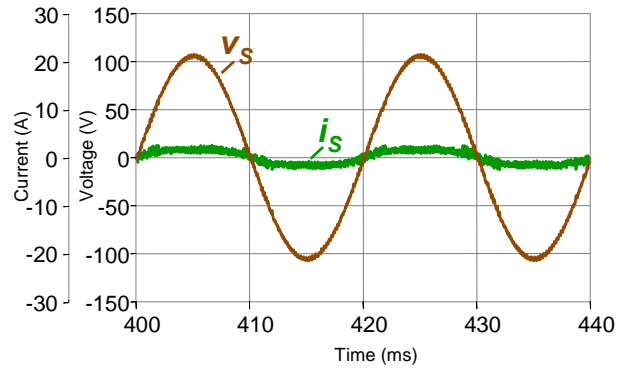

Fig. 4 – Load A: System voltage (v_s) and source current (i_s) after the connection of the active filter to the electric system.

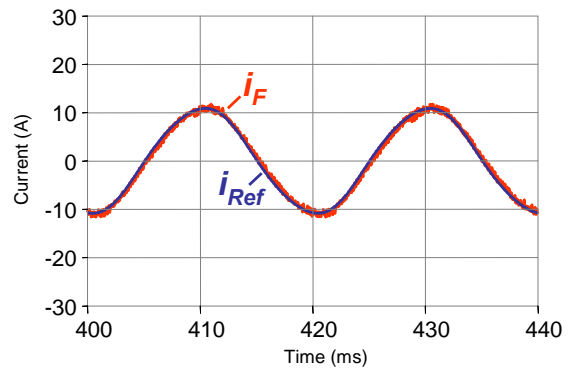

Fig. 5 – Load A: Reference current (i_{ref}) and compensation current (i_f) of the shunt active filter.

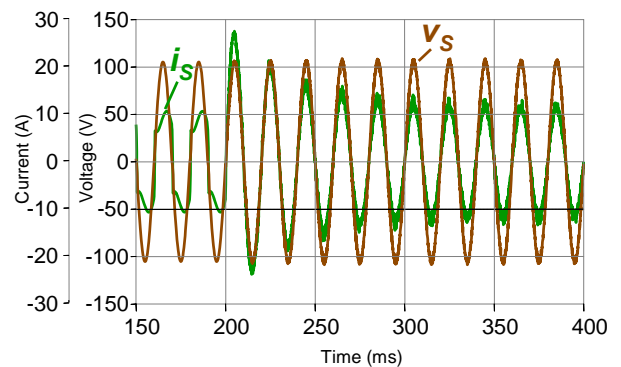

Fig. 6 – Load A: System voltage (v_s) and source current (i_s) when the shunt active filter is turned on (transient operation).

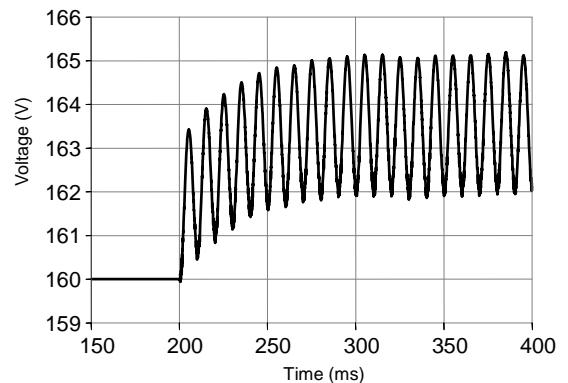

Fig. 7 – Load A: Dc side voltage (v_{dc}) when the active filter is turned on (transient operation).

B. Full Bridge Rectifier with a Series RL Load

This load (named load B) consists of a four diodes full bridge rectifier with an inductor in series with a resistor in the dc side, totalizing 31 mH, 7.7 Ω . Figures 8 to 12 show waveforms obtained from simulation results performed with this type of load. Fig. 8 presents v_S and i_S before the shunt active filter starts its operation. Fig. 9 illustrates the same waveforms after the connection of the shunt active filter to the electric system. Fig. 10 presents the waveforms of i_{ref} and i_F of the active filter. The figures 8, 9 and 10 present waveforms with the power system in steady-state. Fig. 11 shows v_S and i_S , and Fig. 12 presents v_{dc} , when the shunt active filter is connected to the power system (transient operation).

It can be seen from these simulation results that the shunt active filter compensates the current distortion successfully, turning the source currents almost sinusoidal, although some high-frequency components are now observed due to the switching of the active-filter power inverter.

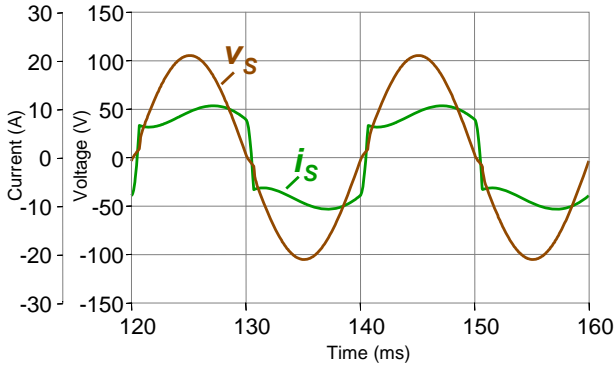

Fig. 8 – Load B: System voltage (v_S) and source current (i_S) before the shunt active filter starts its operation.

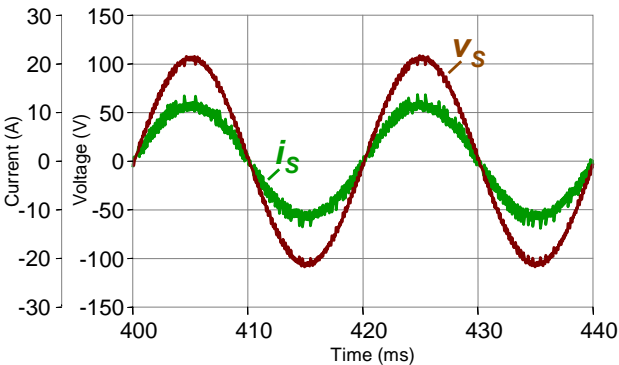

Fig. 9 – Load B: System voltage (v_S) and source current (i_S) after the connection of the active filter to the electric system.

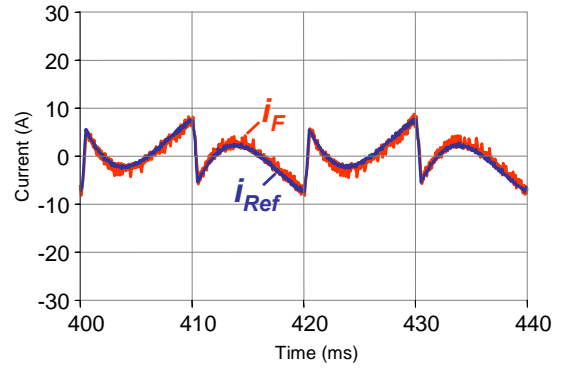

Fig. 10 – Load B: Reference current (i_{ref}) and compensation current (i_F) of the shunt active filter.

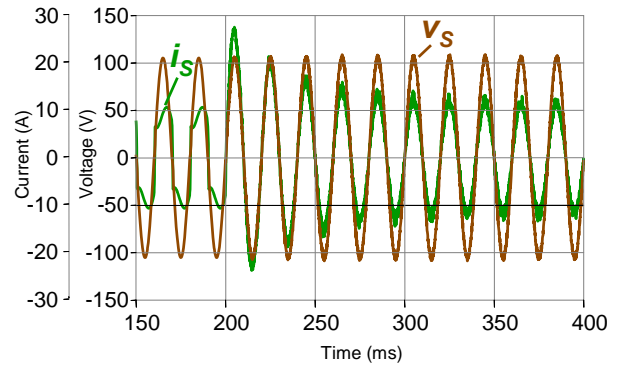

Fig. 11 – Load B: System voltage (v_S) and source current (i_S) when the shunt active filter is turned on (transient operation).

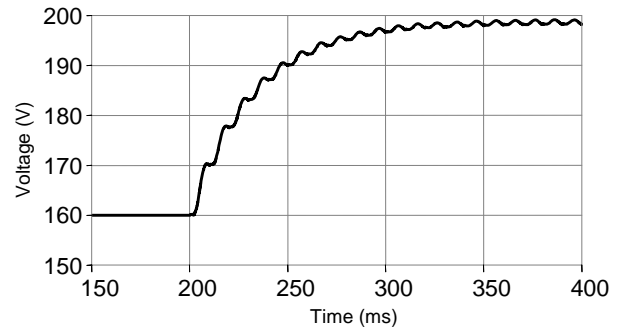

Fig. 12 – Load B: Dc side voltage (v_{dc}) when the active filter is turned on (transient operation).

C. Full Bridge Rectifier with a Parallel RC Load

In this case, the load (named load C) consists of a four diodes full bridge rectifier with a capacitor in parallel with a resistor in the dc side. The capacitance value is 1.9 mF, and the resistance value is 31 Ω . Figures 13 to 17 show waveforms obtained from simulation results performed with this type of load. Fig. 13 shows v_S and i_S before the shunt active filter starts its operation. In Fig. 14 are observed the same waveforms after the connection of the active filter to the electric system. Fig. 15 illustrates the waveforms of i_{ref} and i_F (reference current and compensation current of the active filter). Figures 13, 14 and 15 present waveforms with the power system in steady-state. Fig. 16 presents v_S and i_S , and Fig. 17 shows v_{dc} , when the shunt active filter is connected to the power system (during transient)

operation).

As can be seen from these simulation results, the shunt active filter compensates well the current distortion. However, based on Fig. 14, it can be observed that i_s presents a small distortion due to the fact that the current to be compensated assumes a peak value that is very difficult to be entirely synthesized.

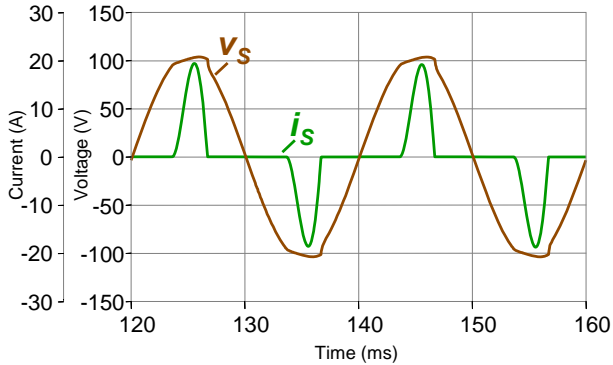

Fig. 13 – Load C: System voltage (v_s) and source current (i_s) before the shunt active filter starts its operation.

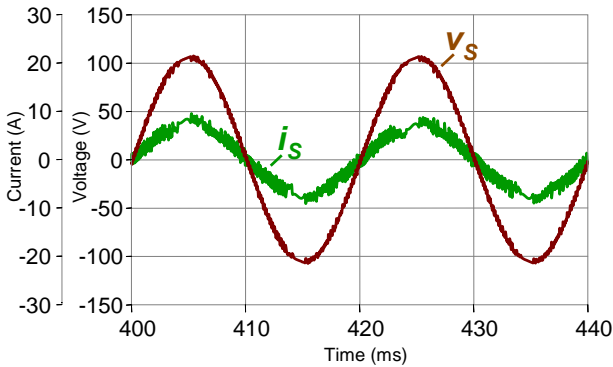

Fig. 14 – Load C: System voltage (v_s) and source current (i_s) after the connection of the active filter in the electric system.

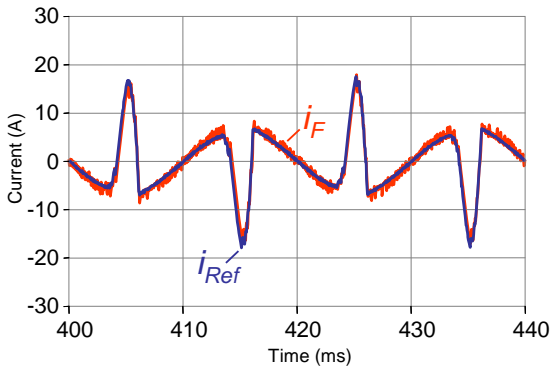

Fig. 15 – Load C: Reference current (i_{ref}) and compensation current (i_f) of the shunt active filter.

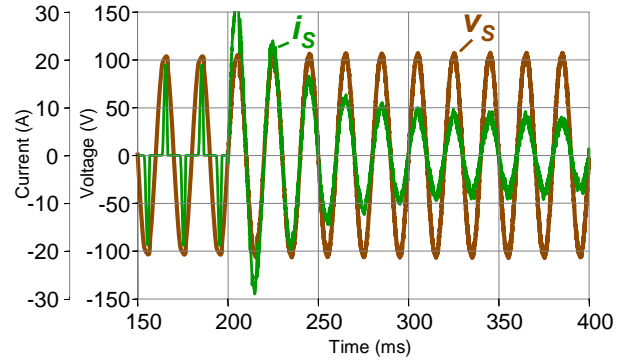

Fig. 16 – Load C: System voltage (v_s) and source current (i_s) when the shunt active filter is turned on (transient operation).

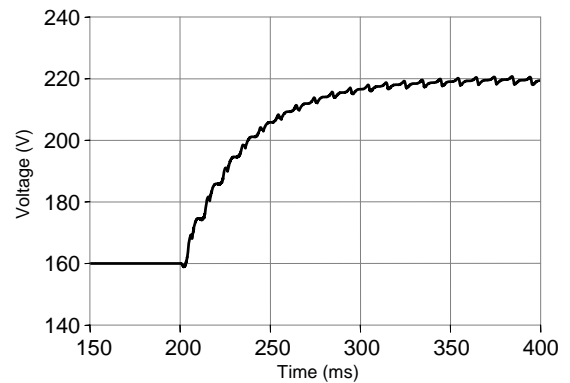

Fig. 17 – Load C: Dc side voltage (v_{dc}) when the active filter is turned on (transient operation).

5. Conclusions and Future Work

This paper presented simulation results obtained with a single-phase shunt active power filter with a control system based on the p-q theory, and operating with Periodic Sampling switching technique, which is a very simple technique, but that does not work with a fixed switching frequency, although establishes an upper frequency limit, which in this work was set to 15 kHz.

The shunt active filter control system is based on a simple stratagem that enables the use of the traditional p-q Theory, originally developed to three-phase power systems, in single-phase systems.

Three different types of loads were used to test the single phase active filter: a linear RL load, a rectifier with RL load, and a rectifier with RC load.

The simulation results proved that the shunt active filter was capable of compensating harmonics currents and correcting power factor for the different types of loads used in the simulations. However it was observed that the performance of the active filter was not totally satisfactory for the case of Load C (full bridge rectifier with a parallel RC load), since the compensated source current presented still some distortion. It happens because this load is very difficult to be compensated, since its current behaves like pulses, that vary from zero to almost 20 A, and then again to zero, in about 3 ms.

It was also possible to see that the transient operation of the shunt active filter when it is turned on does not imply in any problem to the electric system or to the active filter itself.

In a next work, the obtained simulation results will be compared with experimental results, to be measured in a developed single-phase shunt active power filter prototype.

Acknowledgement

This work was supported by FCT (Fundação para a Ciência e a Tecnologia), project funding POCTI/ESE/41170/2001 and POCTI/ESE/48242/2002. The authors are also grateful to PRIME (Programa de Incentivos à Modernização da Economia) for funding the Project SINUS. The author Luís F. C. Monteiro is grateful to Alban program for supporting his education project at the University of Minho.

References

- [1] L. Gyugi and E. C. Strycula, "Active AC Power Filters", IEEE-IAS Annual Meeting Record, 1976, pp. 529-535.
- [2] H. Akagi, Y. Kanazawa, A. Nabae, "Generalized Theory of the Instantaneous Reactive Power in Three-Phase Circuits", IPEC'83 - Int. Power Electronics Conf., Tokyo, Japan, 1983, pp. 1375-1386.
- [3] E.H. Watanabe, R.M. Stephan and M. Aredes, "New Concepts of Instantaneous Active and Reactive Powers in Electrical Systems with Generic Loads," IEEE Trans. on Power Delivery, vol. 8, no. 2, pp. 697-703, April 1993.
- [4] M. Aredes, E.H. Watanabe, "New Control Algorithms for Series and Shunt Three-Phase Four-Wire Active Power Filters," IEEE Trans. on Power Delivery, vol. 10, no. 3, pp. 1649-1656, July 1995.
- [5] Ricardo Pregitzer, J. C. Costa, Júlio S. Martins, and João L. Afonso, "Simulation and Implementation Results of a 3 Phase 4 Wire Shunt Active Power Filter", Proceedings (CD-ROM) ICHQP'2006 - International Conference on Harmonics and Quality of Power, 1-5 Oct. 2006, Cascais, Portugal.
- [6] Haque, M.T.; Ise, T.; "Implementation of single-phase pq theory," Proceedings of the Power Conversion Conference, 2002. PCC Osaka 2002, Volume 2, 2-5 April 2002, pp. 761-765.
- [7] Nabae, A.; Tanaka, T.; "A new approach to individual-phase reactive power compensator for nonsinusoidal and unbalanced three-phase systems-proposal for a quasi-instantaneous reactive power compensator," 8th International Conference on Harmonics and Quality of Power, 1998. Proceedings, Volume 1, 14-16 Oct. 1998, pp. 532-536.
- [8] Willems, J.L.; "A new interpretation of the Akagi-Nabae power components for nonsinusoidal three-phase situations," IEEE Transactions on Instrumentation and Measurement, Volume 41, Issue 4, August 1992, pp. 523-527.
- [9] S. Buso; L. Malesani; P. Mattavelli; Comparison of Current Control Techniques for Active Filter Applications; IEEE Transactions on Industrial Electronics, vol. 45, Issue 5, October 1998; pp. 722-729.