

Concrete Reinforced by Braided Fibre Composite Rods

R. Fangueiro*, F. Soutinho*, G. Sousa*, S. Jalali** and M. de Araújo*

*Department of Textile Engineering, University of Minho
Campus de Azurém, 4800 Guimarães, PORTUGAL
Tel. +351 253 510 280 Fax: +351 253 510 293
rfang@det.uminho.pt

**Department of Civil Engineering, University of Minho
Campus de Azurém, 4800 Guimarães, PORTUGAL
Tel. +351 253 510 200 Fax: +351 253 510 217

Abstract — This paper describes the work that is being done at the University of Minho concerning the development of braided rods for concrete reinforcement.

A preliminary research study has been conducted to understand the mechanical behaviour of braided fabrics. The tensile properties of these samples have been evaluated and the results presented.

In order to produce braided reinforced composite rods to use as a concrete reinforcement, a special technique has been developed using a standard vertical braiding machine. Special samples have been prepared and tested to evaluate the adherence between both materials involved. The tensile and bending properties of braided reinforced composite rods have been evaluated and the results obtained presented and discussed.

Concrete beams reinforced by braided composite rods, have been prepared and tested. The results obtained are presented and compared with those obtained for conventional concrete beams reinforced by steel rods

1. Introduction

Concrete structures are subjected to repeated loading and to aggressive environmental agents which may lead to poor mechanical and durability performance of the structures with time. One of the most serious problems affecting concrete is corrosion of the steel reinforcement. As shown in Fig.1 corrosion may occur due to reaction of lime present in hydrated cement with carbon dioxide or to the action of chlorides. In the first case, the lime reaction with the carbon dioxide present in the atmosphere leads to a gradual decrease in concrete alkalinity. When the pH of the concrete cover is lower than 9 the compact oxide layer that protects the steel is destroyed, thus leading to the formation of electrochemical reactions which are responsible for the corrosion of the steel. The chloride ion attack is due mainly to migration of chlorides ions present in the vicinity of the structure. It is accepted that when the chloride ions reach a given critical amount the potential for steel corrosion increases significantly. This fact is particularly hazardous in marine or structures in contact with de-icing salts.

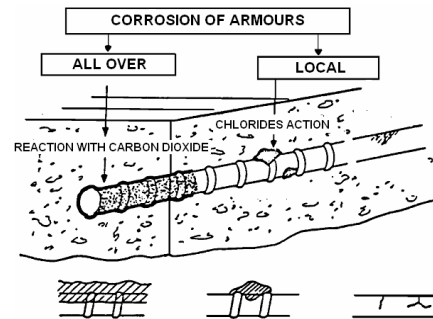

Fig. 1. Corrosion of steel armours

The braiding technique is probably the most ancient production process for textile structures. Normally used for ropes and cables, braided fabrics are also very interesting for composite reinforcements due to their characteristics: in-plane multiaxial orientation, conformability, excellent damage tolerance and cost. The braiding technique can produce a wide range of preforms for composite reinforcements (T's, I's, hollow fabrics), however, the number of yarn bobbins in the braiding machine limits the dimensions of the fabric.

2. Braided Reinforced Composite Rods

In order to overcome problems encountered during previous research works on concrete reinforced by glass-braided fabrics, braided reinforced composite rods have been produced and tested. Moreover, the adhesion between concrete and composite rods has also been evaluated and discussed.

2.1 Production

The samples have been produced on a conventional braiding machine specially adapted to impregnate simultaneously the braided fabrics. In order to increase roughness of the braided reinforced composite material rods, and then its adhesion to the concrete, braided

fabrics have been produced as a ribbed structure, as shown in Figure 2. This ribbed structure is provided by thicker yarns that are used in the braiding machine in a combination of 7 standard to 1 thicker yarn. For a stronger effect on roughness the number of thicker yarns could be increased during braiding the process.



(a) (b)

Fig. 2. Ribbed structure

(a) braided fabric (b) braided reinforced composite rod

The glass braided fabrics have been produced and simultaneously impregnated with a polyester thermosetting resin during the braiding process. The characteristics of the composite material rods produced are shown in Table 1.

Table 1 - Characteristics of the composite material rods

Braided fabric type	Fibre type	Thickness (mm)	Fiber volume fraction (%)	Resin type
Core reinforced	Braiding yarns: 110 tex, E glass fiber Core reinforcement: 12 E glass fiber 900 tex rovings	3.7	63.44	polyester

2.2 Mechanical Properties

For the evaluation of the tensile properties of the braided reinforced composite rods produced, experimental work has been undertaken using a HOUNSFIELD universal tensile tester, according to ASTM D638 standard, at a cross-head speed of 1 mm/min. The results obtained are shown in Table 2 while Figure 3 shows the typical load-extension curve.

Table 2 – Tensile properties of composite reinforced rods

Final Strength	Extension at maximum stress (%)	Young's Modulus (Mpa)
946,81	6,93	17700

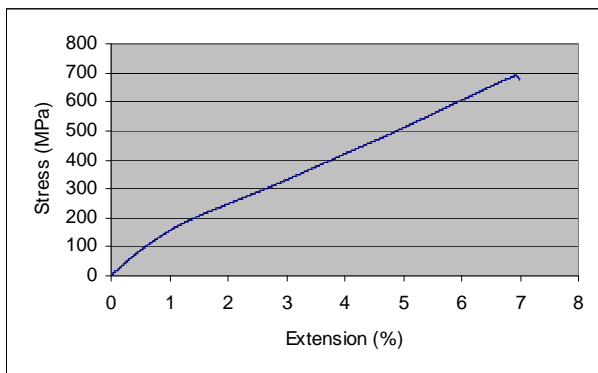

Fig. 3. Typical stress-strain curve for braided reinforced composite rods

2.3 Adhesion to the Concrete

In order to evaluate the adherence between the braided composite rods and the concrete, 8 samples have been prepared, as shown in Figure 4. The samples have been tested (Figure 5) on a universal tensile tester, at a cross-head speed of 0.1 mm/s, according to standard NP EN 10002-1 usually used for steel. The braided composite rods have completely adhered to the concrete up to the breaking point



Fig. 4. Samples for adherence test



Fig. 5. Adherence test

3. Concrete Beams Reinforced by Braided Reinforced Rods

3.1 Samples Preparation

Three concrete beams reinforced by an armour of braided composite rods (Figure 6) and three concrete beams reinforced by an armour of steel were prepared. The dimensions of the beams are presented in Figure 7.



Fig. 6. Composite rods reinforcements used

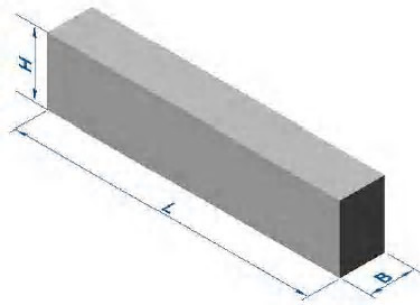

Fig. 7. Beam dimensions
(B=10 cm H=15 cm L=65 cm)

The curing process occurred in three different steps: 24h in the place where the beams were made; 20 days in water at a temperature of 20 °C; 6 days at a room temperature of 20°C. (Figure 8)



Fig. 8. Concrete beams reinforced by composite rods

3.2 Testing and Results

The beams have been tested in bending in a servo-controlled system with a speed of 10 $\mu\text{m/s}$. The displacements and the corresponding loads were registered. (Figure 9).



Figure 9 – Three point bending test for concrete beams reinforced by composite rods

Tables 3 and 4 present the results obtained for each type of beam tested.

Table 3. Bending test results for beams reinforced by steel

	Strength (Kn)	Elongation at Failure (mm)
Beam 1	58,1	4,4
Beam 2	63,3	2,5
Beam 3	60,1	3,4
Mean	60,5	3,4

Table 4. Bending test results for beams reinforced by composite rods

	Strength (Kn)	Elongation at Failure (mm)
Beam 1	32,5	8,2
Beam 2	30,3	4,8
Beam 3	30,7	6,4
Mean	31,3	6,5

Figure 10 presents a beam after testing. The broken braided reinforced composite rods are shown.



Fig. 10. Beam produced with braided reinforced composite rods after testing

Figure 11 presents the load-deformation curves for each type of beam tested.

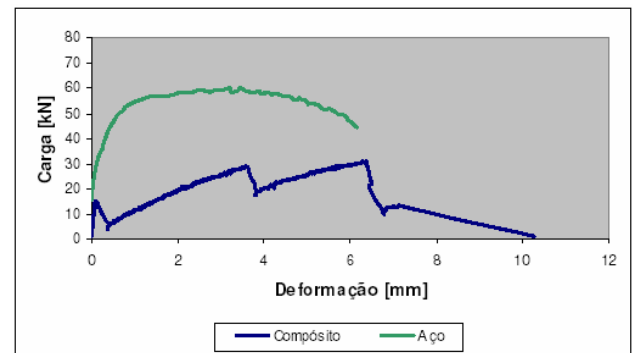

Fig. 11. Load-strain curves for concrete beams reinforced by composite rods and steel

4. Conclusions

Analysing the results obtained and the correspondent load-extension curves it is possible to detect different performances between both types of beams tested. The steel reinforced beams carry twice as much load compared to composite reinforced beams. Moreover, strain values of the steel reinforced beams are lower than those obtained for beams reinforced by the composite rods. In the load-strain curves obtained for the composite reinforced beams, three peaks are visible that correspond to the breaking point of each of the composite rods used. These peaks show that the rods in the reinforcement are not stressed simultaneously. Moreover, the first peak indicates that the reinforcement is not bearing the full load at the initial stage of testing. This behaviour is probably due to the rather loose state of the composite

rods that are tensioned only after some considerable deformation of the beam. Another problem encountered is the fact that composite rods have a lower modulus of elasticity when compared to that of the steel rods used, i.e. 18 GPa compared to 210 GPa.

Further research work is being undertaken in order to overcome the problems encountered and reported in this work. The technology used to produce the braided composite rods is being improved in order to allow the placement of straight fibers inside the braided fabric and to allow a better distribution of the resin. The samples are now being produced with a higher density of roving in the core so that the mechanical properties of the material may be improved. Also, the beams will be longer in order to enable four point bending tests to be performed so that the results obtained may be more representative.

References

- Fangueiro, R.; Soutinho, F; Jalali, S. and Araújo, M. (2004), Development of Braided Fabrics For Concrete Reinforcements, Proceedings of 4th AUTEX CONFERENCE, Roubaix, France, 22-24 June.
- Ferreira, José (2003), Desenvolvimento de Estruturas de Reforço para Componentes de Veículos Automóveis, Relatório de Estágio, Universidade do Minho, Guimarães, Portugal.
- Ko, F.K., (1989), "Three dimensional Fabrics for composites", Textile Structural Composites: Series 3, Chou, T.W. and Ko, F.K., Editors, Elsevier, New York.
- Mendes, M T., Gonçalves S. C., Alves, S. M.(2004), "Elementos Estruturais Entrançados para Reforço do Betão", Projecto da Universidade, Universidade do Minho, Guimarães, Portugal
- Pastore, Christopher, Ko, Frank and Harris, Harry (2004), "Braided Hybrid Composites for Bridge Repair and Construction",
- Somboonsong, W. (1997), "Development of ductile hybrid fiber reinforced polymer (D-H-FRP) for concrete structures", *Ph.D.Thesis*, Department of Civil and Architectural Engineering, Drexel University, Philadelphia, PA, December.
- Sousa, G. (2004), "Estruturas entrançadas para reforço do betão", Master Thesis, University of Minho, Guimarães, Portugal.

This document was created with Win2PDF available at <http://www.daneprairie.com>.
The unregistered version of Win2PDF is for evaluation or non-commercial use only.