



hilotec

# Self-building Manual for Sustainable Housing

Luís F. Ramos, Thomas Sturm, Diogo Gomes, Paulo Mendonça, Rute Eires, Aires Camões, Paulo B. Lourenço



University of Minho  
School of Engineering





University of Minho  
School of Engineering

The **University of Minho** is currently among the most prestigious institutions of higher education in Portugal, and it has also gradually come to assert itself on the international scene. Founded in 1973, the University's mission is focused on the creation, dissemination and application of knowledge, under the spirit of freedom of thought and plural critical judgments, through the promotion of higher education and the construction of a society paradigm based on humanistic principles, and having knowledge, creativity and innovation as cornerstones for growth, sustainable development, welfare and solidarity.



The **ISISE – Institute for Sustainability and Innovation in Structural Engineering** and the **C-TAC – Centre of Territory Environment and Construction**, are two research centers of the Civil Engineering Department at the University of Minho. These centers aim at promoting innovation and sustainability, with a close link to the construction sector industry. One common field of work is the study of sustainability of the built and natural environment, including sustainable housing. In the **HiLoTec** project, which resulted in the present self-construction manual, the goal was to combine knowledge and innovation as the key ingredients for wealth generation for developing countries.

# HLT hilotec

## Self-building Manual for Sustainable Housing

**Authors**  
Luís F. Ramos, Thomas Sturm, Diogo Gomes,  
Paulo Mendonça, Rute Eires, Aires Camões,  
Paulo B. Lourenço

Simple, economical and sustainable  
earth technology solution to build  
your own house



University of Minho  
School of Engineering



Institute for Sustainability  
and Innovation  
in Structural Engineering



Centre of Territory  
Environment and Construction



FUNDAÇÃO MANUEL  
ANTÓNIO DA MOTA



**Publisher**  
University of Minho – Department of Civil Engineering

**Authors**  
Luís F. Ramos, Thomas Sturm, Diogo Gomes, Paulo Mendonça,  
Rute Eires, Aires Camões, Paulo B. Lourenço

**Graphic Design**  
Typeface Design

© 2014 Authors and Publishers

All rights reserved. No part of this publication may be reproduced, stored in a retrieval system, or transmitted, in any form or by any means without the prior written permission of the publisher.

ISBN 978-972-8692-88-9

DL 381778/14

The Editors, the Authors and the publisher are not responsible for the use, which might be made of the following information.

September 2014, 90 copies

Printed in PORTUGAL

## 1 | Introduction

1.5 | Introduction

## 2 | Soil Selection

2.2 | Objectives  
2.2 | Materials and Tools  
2.3 | Construction Place  
2.4 | Collecting Soil  
2.4 | Hand Test of the Soil  
2.5 | Ball Test of the Soil  
2.6 | Cigar Test of the Soil  
2.7 | Bottle Test of the Soil  
2.7 | Further Technical Information

## 3 | Manufacturing Blocks

3.2 | Objectives  
3.2 | Materials and Tools  
3.3 | Blocks  
3.4 | Producing the Blocks  
3.5 | Collecting the Soil  
3.5 | Sieving  
3.6 | Mixing Soil, Cement and Water  
3.7 | Pressing the Block  
3.8 | Storing  
3.8 | Curing and Drying  
3.9 | Testing the Block  
3.9 | Blocks Results

## 4 | Construction of Foundations

4.2 | Objectives  
4.2 | Materials and Tools  
4.3 | Construction Working Platform  
4.4 | First Marking Steps  
4.5 | Second Marking Steps  
4.6 | Digging  
4.7 | Foundation  
4.7 | Type of Foundation  
4.8 | Type of Foundation  
4.9 | Location of Reinforcements  
4.9 | Ground Floor  
4.10 | 1st Row  
4.11 | Reinforcement

## 5 | Building Walls

5.2 | Objectives  
5.2 | Materials and Tools  
5.3 | Damaged Blocks  
5.4 | 1st Row  
5.5 | 2nd Row  
5.6 | Construct the Walls  
5.6 | Corners  
5.7 | Meeting of Walls  
5.7 | Corners  
5.8 | Reinforcement  
5.9 | Horizontal Course  
5.10 | Construction of Windows  
5.11 | Last Row before concrete  
5.11 | Reinforcement of Ring Beam  
5.12 | Concrete Mixture and Formwork  
5.13 | Concrete Formwork

## 6 | Construction of the Roof

6.2 | Objectives  
6.2 | Materials and Tools  
6.3 | Placement of Purlins  
6.3 | Construct Wedges  
6.4 | Placing the Purlins  
6.5 | Roof Structure  
6.6 | Roof Cover

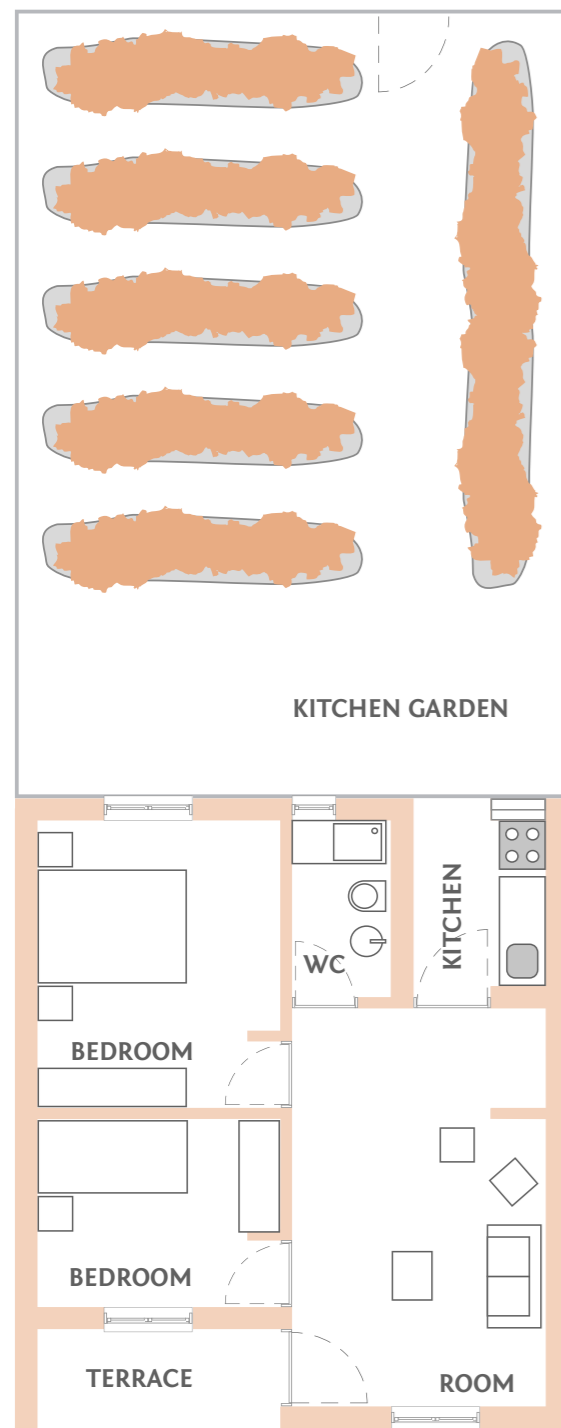

ISOLATED HOUSE



MAIN ELEVATION

REAR ELEVATION



ROW-HOUSES

## The HiLoTec project

Development of a Sustainable Self-Construction System for Developing Countries

The future of the construction industry will require changes at many levels. One is the ability of companies to adapt to new challenges, converting needs to opportunities and simultaneously contributing to the solving of social and environmental problems. In the coming decades we will see a change in attitude in the industry, with a strong tendency to adopt natural and recycled materials, as well as bet on green technology and social innovation oriented to emerging countries.

On the other hand, emerging countries have a high demand for housing construction on a large scale, but the current techniques in the developed countries for building requires a large amount of natural resources and skilled labor. This contextualization brings sustainability problems for the construction sector in emerging countries, often with scarce natural resources and with the construction sector underdeveloped.

Through a cooperative action between the construction company Mota-Engil Engineering and the University of Minho in Portugal, a construction technology was developed based on the use of Compressed Earth Blocks as part of a social concept for innovative small houses, favoring the adoption of local and natural materials and with the main premise of being dedicated to self-construction.

The HiLoTec project - Development of a Sustainable Self-Construction System for Developing Countries was based on this idea. One of the several results of this project is this construction manual.

To Mota-Engil the project was a platform for incubation of knowledge about earth construction and to obtain a constructive solution validated technically and scientifically, suitable to be implemented in the markets where it operates.

For the University of Minho the project was an opportunity to strengthen skills in research, laboratory and scientific development, through the development of engineering studies, architecture and sustainability, as well as supporting the doctoral scholarships and dissemination of scientific publications.

May the knowledge of this project be of benefit, in the future, for the welfare of those who build a HiLoTec house.



# HLT hilotec

Self-building Manual  
for Sustainable Housing



University of Minho  
School of Engineering



info: [www.civil.uminho.pt/hilotec](http://www.civil.uminho.pt/hilotec)

# HLT hilotec

Self-building Manual  
for Sustainable Housing

- 1 | Introduction
- 2 | Soil Selection
  - 2.2 | Objectives
  - 2.2 | Materials and Tools
  - 2.3 | Construction Place
  - 2.4 | Collecting Soil
  - 2.4 | Hand Test of the Soil
  - 2.5 | Ball Test of the Soil
  - 2.6 | Cigar Test
  - 2.7 | Bottle Test
  - 2.7 | Further Technical Information
- 3 | Manufacturing Blocks
- 4 | Construction of Foundations
- 5 | Building Walls
- 6 | Construction of the Roof



University of Minho  
School of Engineering



Objectives

In this Chapter you will learn how to select the right soil for your house!

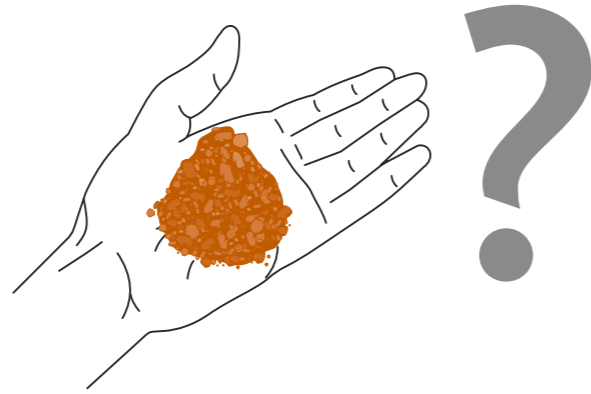

Materials and Tools

These are the materials and tools that you will need in this phase: one bottle, a shovel, and a hoe.



Construction Place

To construct the house you must choose the right place!

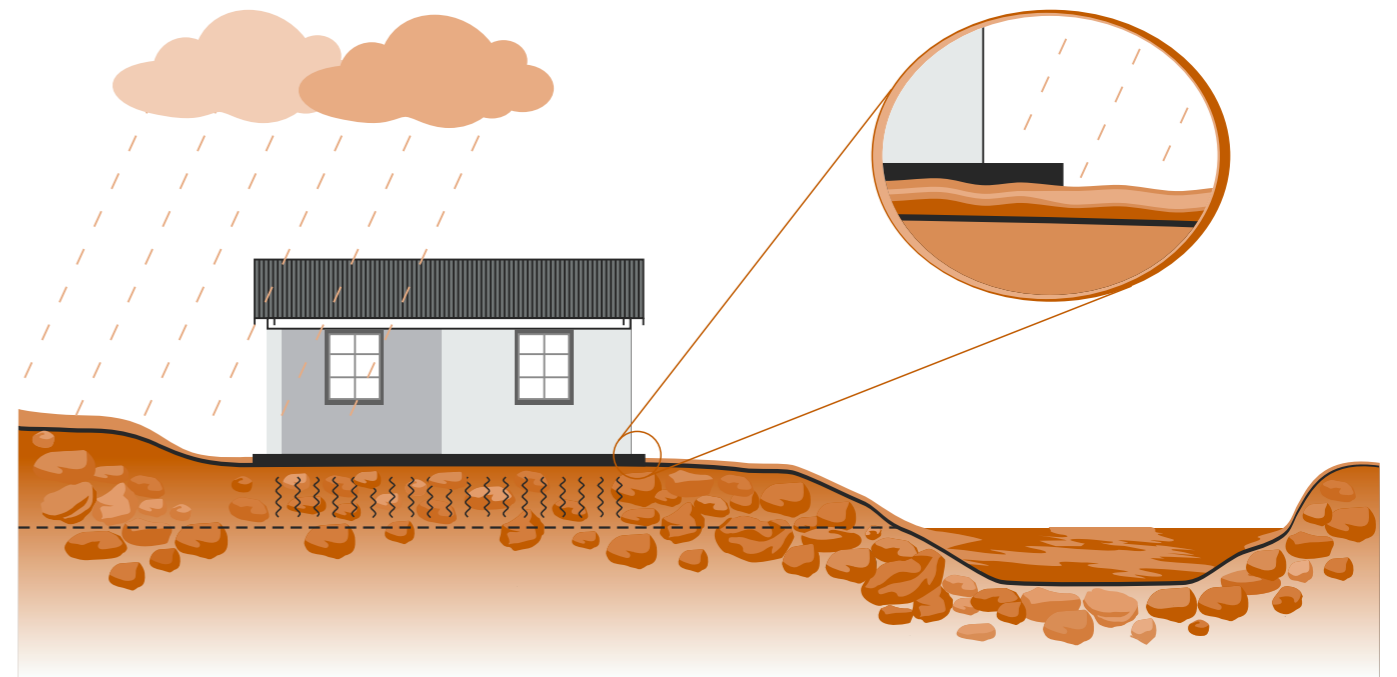
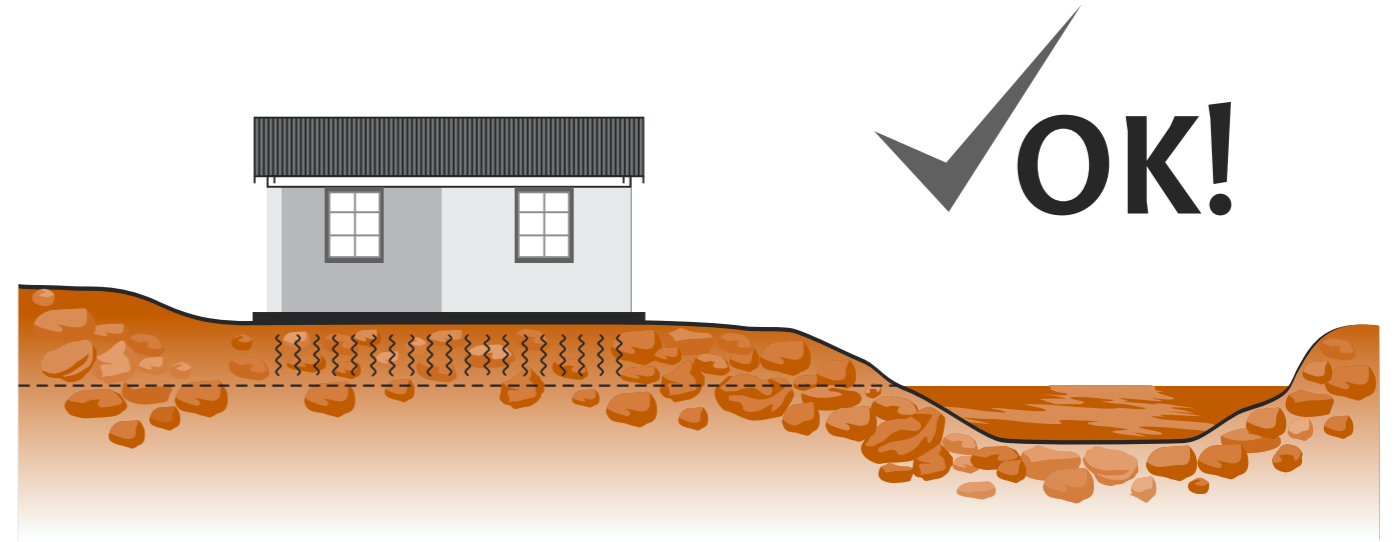

### Collecting the soil

You must collect the soil below 50 cm of the surface. Generally, the surface soil is not good for construction.

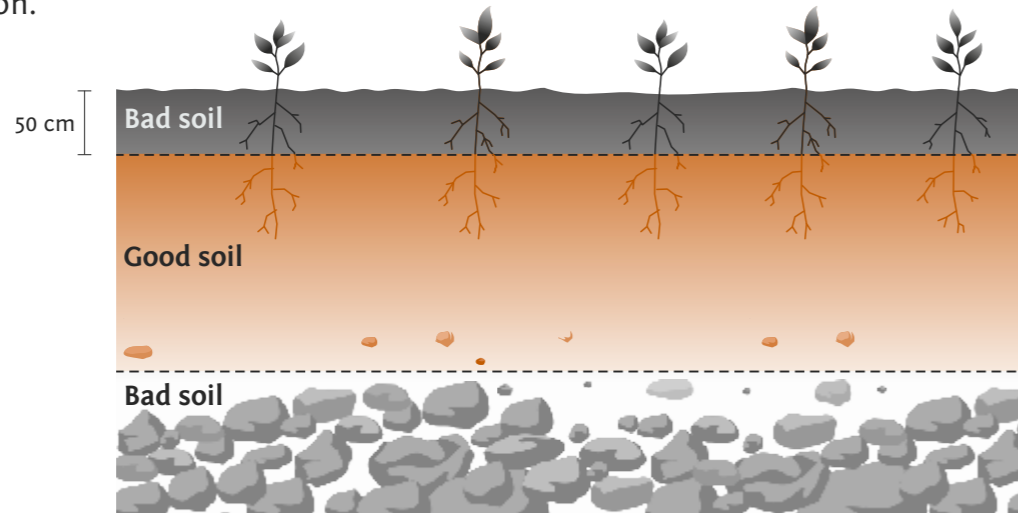

### Hand Test of the Soil

- 1 Take some soil and put it in your hand.
- 2 Add a little bit of water.
- 3 Mix it very well.
- 4 Smell the soil
- 5 Clean your hand.

**Result** Does it smell like an organic material or is it hard to wash your hand? If yes, the soil is not OK! (you can't use this soil)

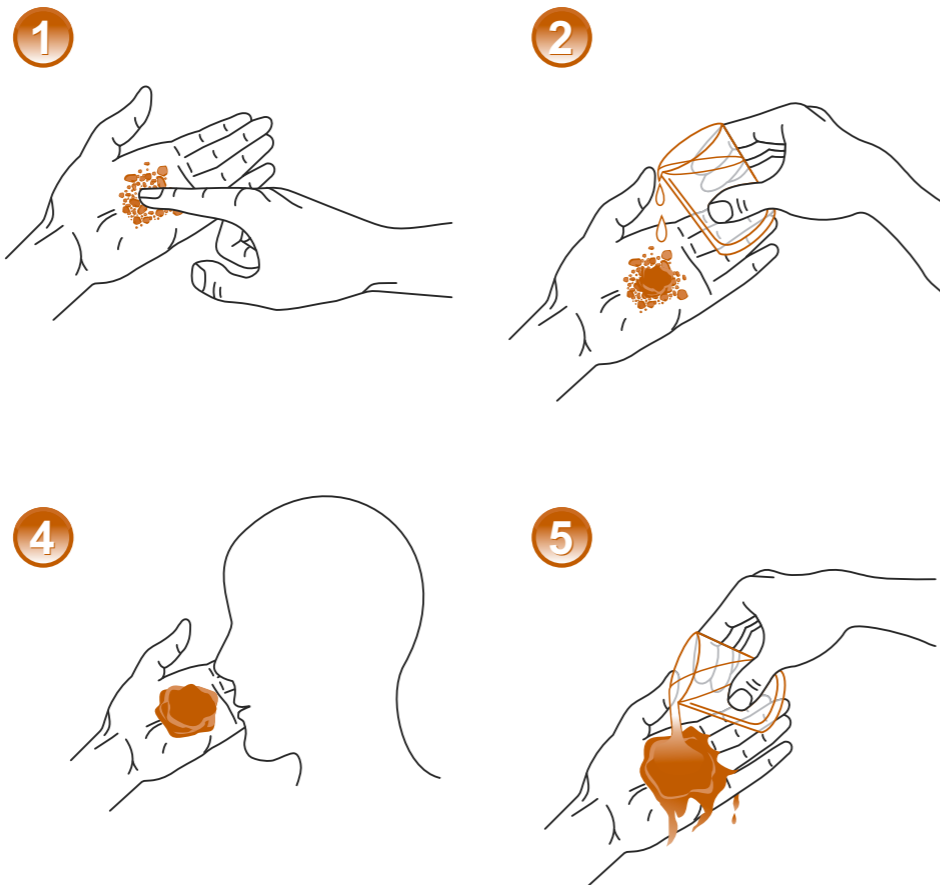

### Ball Test of the Soil (recommended)

- 1 Take a portion of soil and put it in your hand.
- 2 Add a little bit of water.
- 3 Make a ball with your hands.
- 4 Cut the ball into two parts with your hands.

**Result** Can you make the ball? When you cut the ball with your hands, if it doesn't crumble it is OK (you can use this soil).

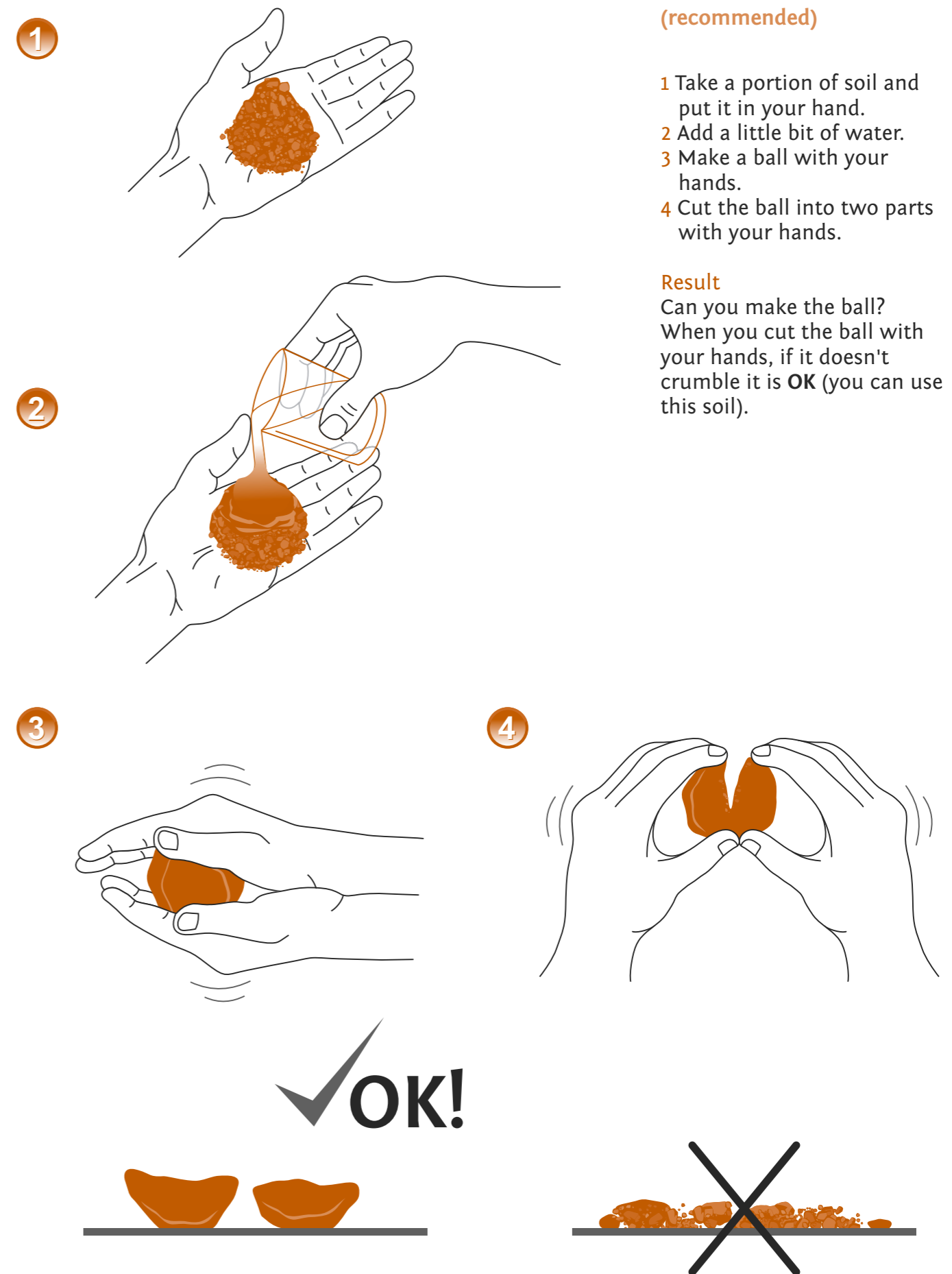

**Cigar test**

- 1 Take some soil and put it in your hand.
- 2 Add a little bit of water.
- 3 Mix all very well.
- 4 With your hands, make a 30 cm long "cigar" with 2.5 cm of thickness.
- 5 Put the "cigar" on a table.
- 6 Push the "cigar" gently with your hand over the edge until it breaks off.
- 7 Measure the part that is left on the table.

**Result** Is the part left on the table between 15 to 25 cm in length? **OK** (you can use this soil)

**Note** You must repeat this test a few times

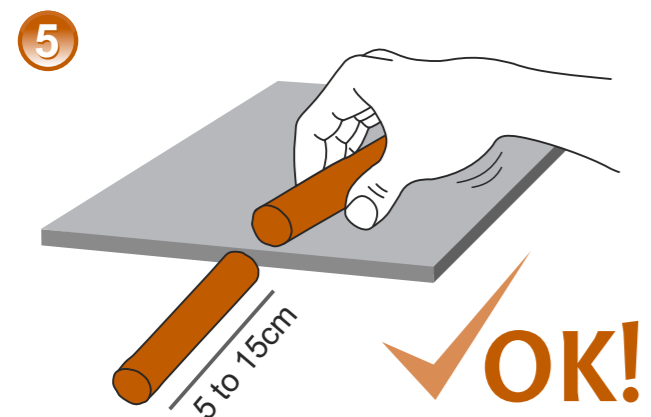
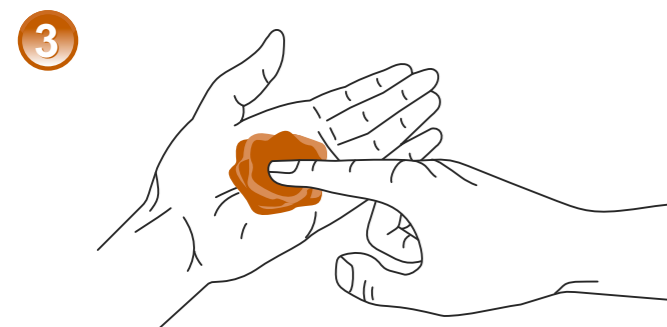
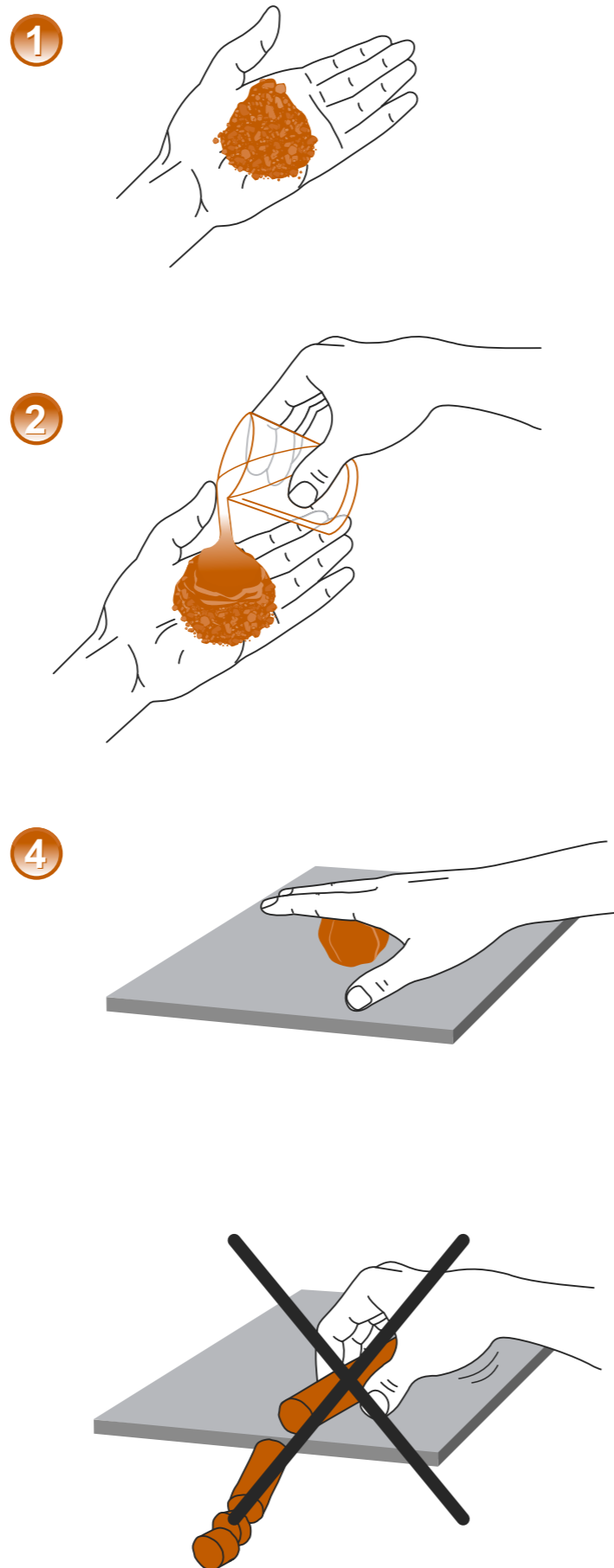

**Bottle Test**

- 1 With a bottle of 1.5 L, fill 1/4 of the bottle with soil without gravel and 3/4 with water.
- 2 Shake the bottle very well.
- 3 Let the bottle rest for 30 minutes vertically.
- 4 Measure the thickness of the soil layers.

**Results** If the sand and gravel part is around 3/4 of the soil portion the soil is good for CEB production.

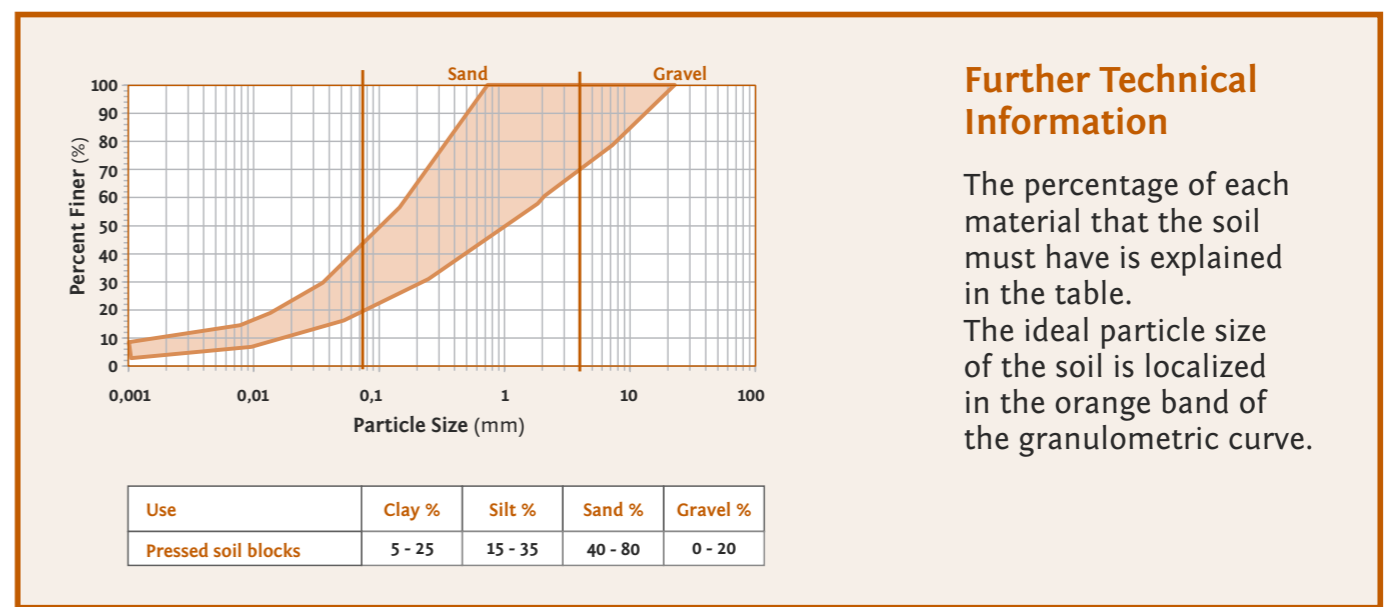
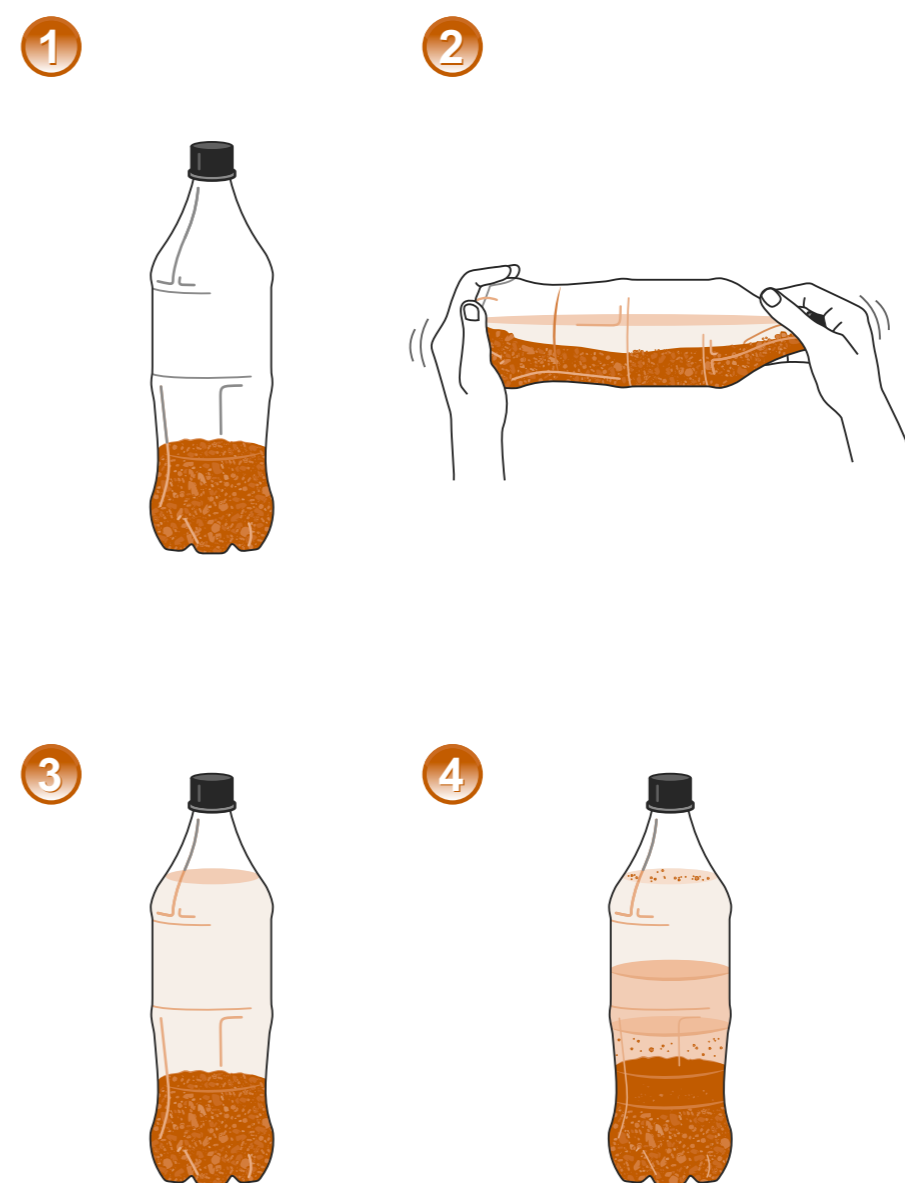

**Further Technical Information**

The percentage of each material that the soil must have is explained in the table. The ideal particle size of the soil is localized in the orange band of the granulometric curve.

# HLT hilotec

Self-building Manual  
for Sustainable Housing



University of Minho  
School of Engineering



Institute for Sustainability  
and Innovation  
in Structural Engineering



Centre of Territory  
Environment and Construction



FUNDAÇÃO MANUEL  
ANTÓNIO DA MOTA

info: [www.civil.uminho.pt/hilotec](http://www.civil.uminho.pt/hilotec)

# HLT hilotec

Self-building Manual  
for Sustainable Housing

- 1 | Introduction
- 2 | Soil Selection
- 3 | **Manufacturing Blocks**
  - 3.2 | Objectives
  - 3.2 | Materials and Tools
  - 3.3 | Blocks
  - 3.4 | Producing the Blocks
  - 3.5 | Collecting the Soil
  - 3.5 | Sieving
  - 3.6 | Mixing Soil, Cement and Water
  - 3.7 | Pressing the Block
  - 3.8 | Storing
  - 3.8 | Curing and Drying
  - 3.9 | Testing the Block
  - 3.9 | Blocks Results
- 4 | Construction of Foundations
- 5 | Building Walls
- 6 | Construction of the Roof



University of Minho  
School of Engineering



Institute for Sustainability  
and Innovation  
in Structural Engineering



Centre of Territory  
Environment and Construction



FUNDAÇÃO MANUEL  
ANTÓNIO DA MOTA





**Objectives**

In this Chapter you will learn how to make the blocks for your house!

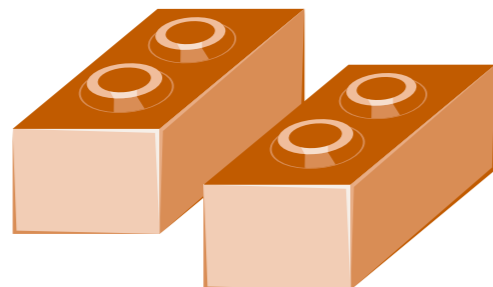

**Materials and Tools**

These are the materials and tools that you will need in this phase: **machine to produce the blocks, shovel, hoe, bucket, water, cement, sieve and plastic sheets to cover the blocks.**

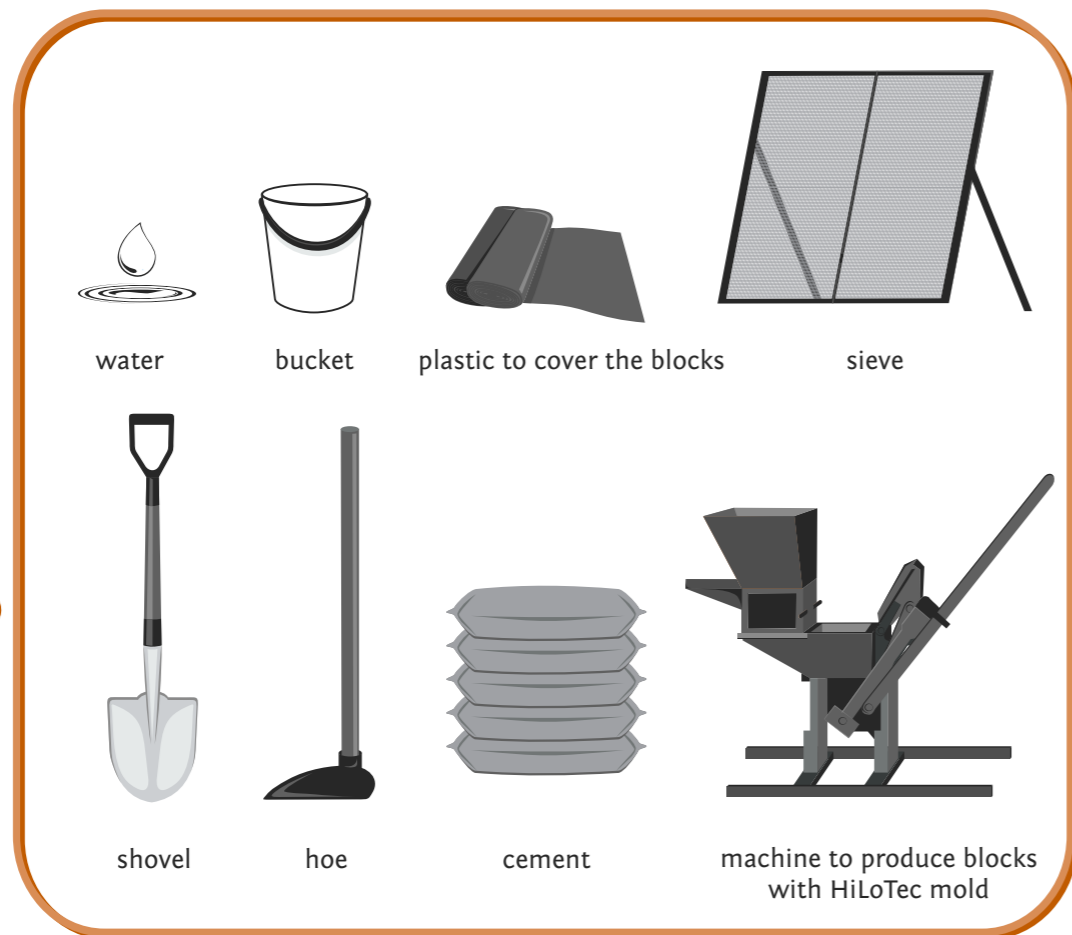

**Blocks**

These are the blocks that you will produce to build your house! You will need to make standard blocks and some half blocks. Pay attention to the block dimensions. It is very important that you respect them.

**Standard Block**

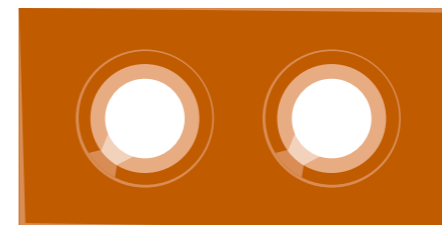

**Half Block**

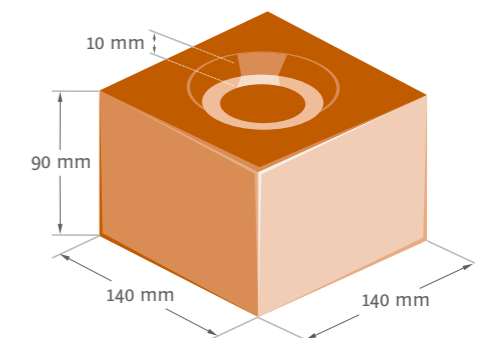
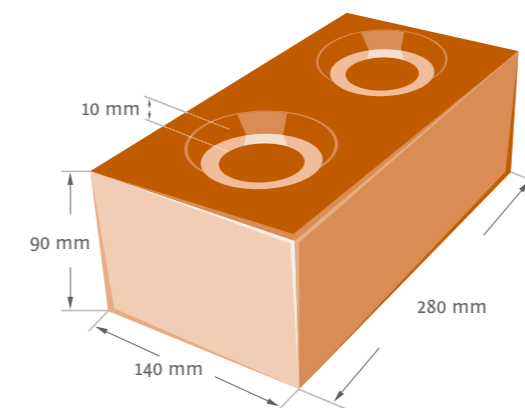
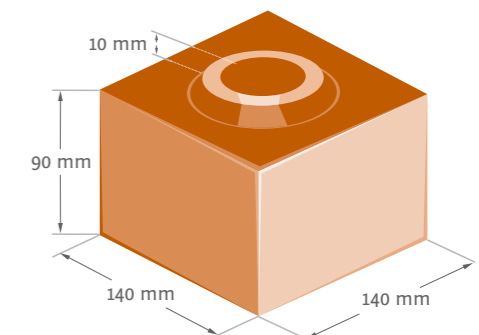
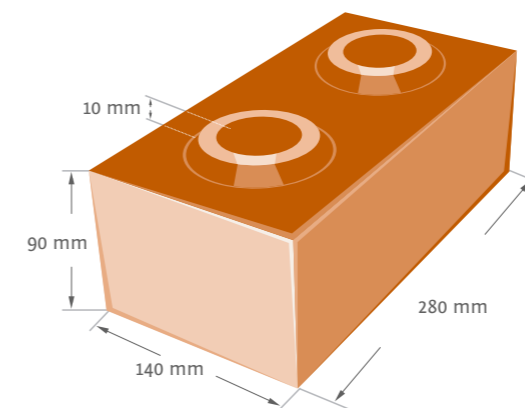

**Producing the Blocks**

This is the process that you must follow to produce the blocks.

- 1 Collecting the soil
- 2 Sieving
- 3 Mixing soil, cement and water
- 4 Pressing the block
- 5 Storing
- 6 Curing and drying

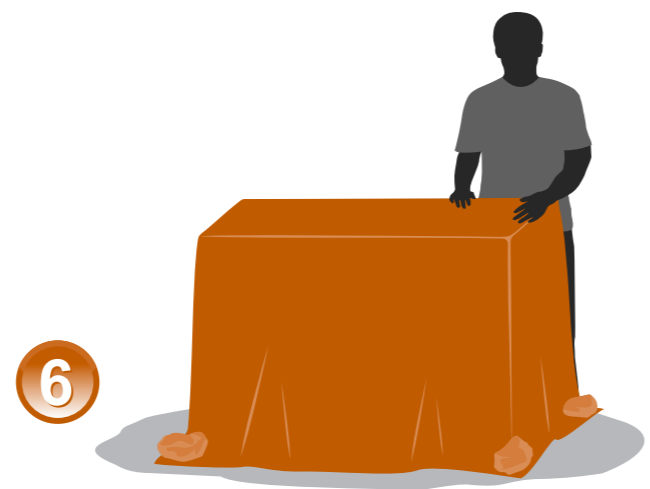
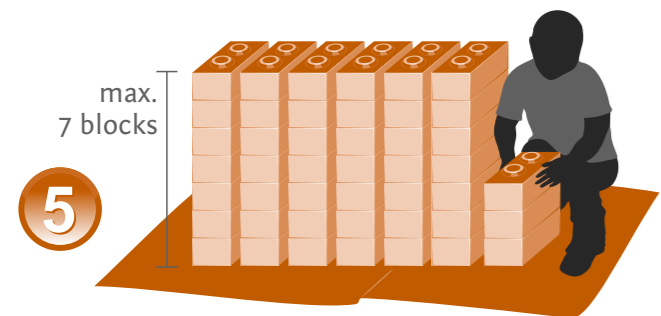
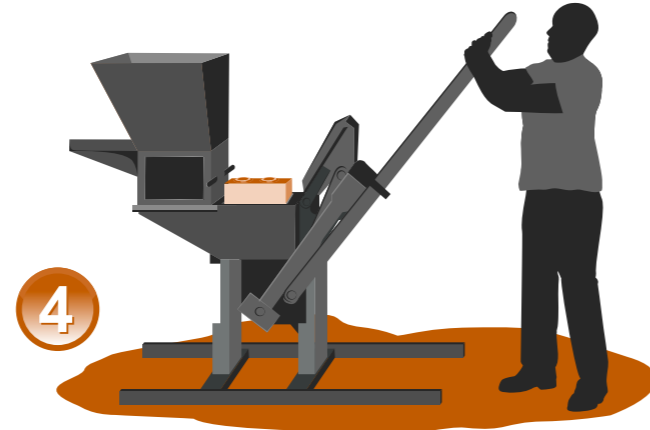
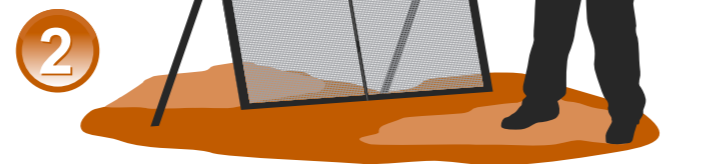
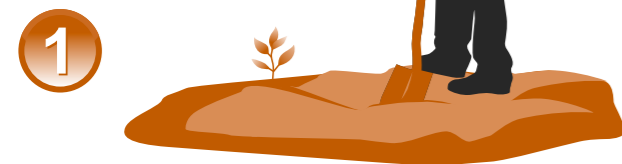

**Collecting the Soil**

You must collect the soil below 50 cm of the surface. Generally, the surface soil is not good for construction.

**Zone 1** Known as topsoil, the soil in this zone is likely to contain organic matter and is usually dark in colour.

**Zone 2** Soil in this zone is likely to be beige in colour and will be very sticky if it has a high clay content. Under wet conditions, puddles of water will form on clay soils and the texture will be slippery and easy to touch.

**Zone 3** Soil in this zone usually contains sandy soil which is more difficult to excavate. It retains no free water, and will feel gritty.

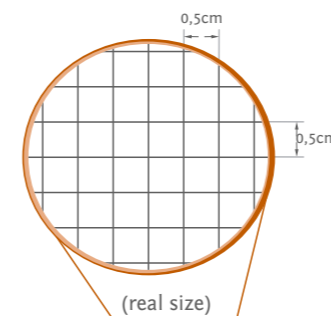
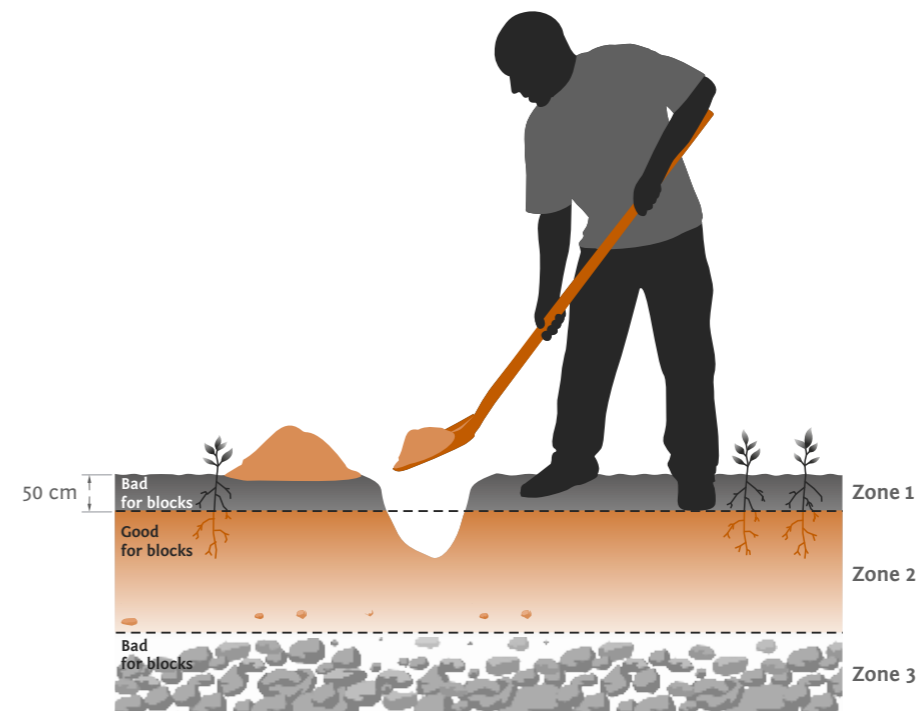

**Sieving**

The sieve must have a net with 5mm width.

### Mixing soil, Cement and Water

For the soil mixture you need 19 buckets of earth and 1 of cement.

Mix the soil with the cement and add a bucket of water. Mix it well!

Take a portion of soil and make the ball test, to see if the you have to put in more water.

#### Ball test

- 1 Take a portion of soil and put it in your hand.
- 2 Add a little bit of water.
- 3 Make a ball with your hands.
- 4 Cut the ball in two parts with your hands.

**Result** Can you make the ball?  
When you cut the ball with your hands if it doesn't crumble, it is **OK** ( you can use the mix).

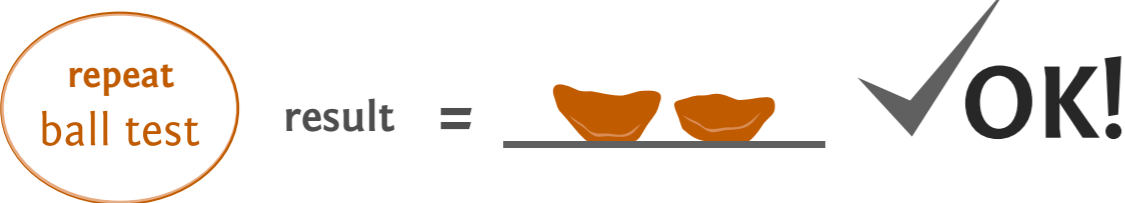
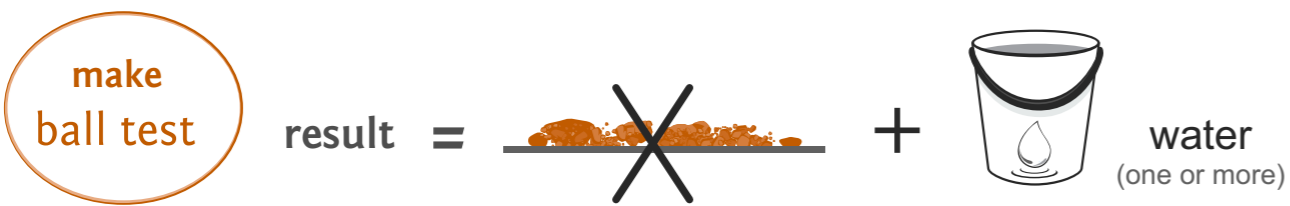
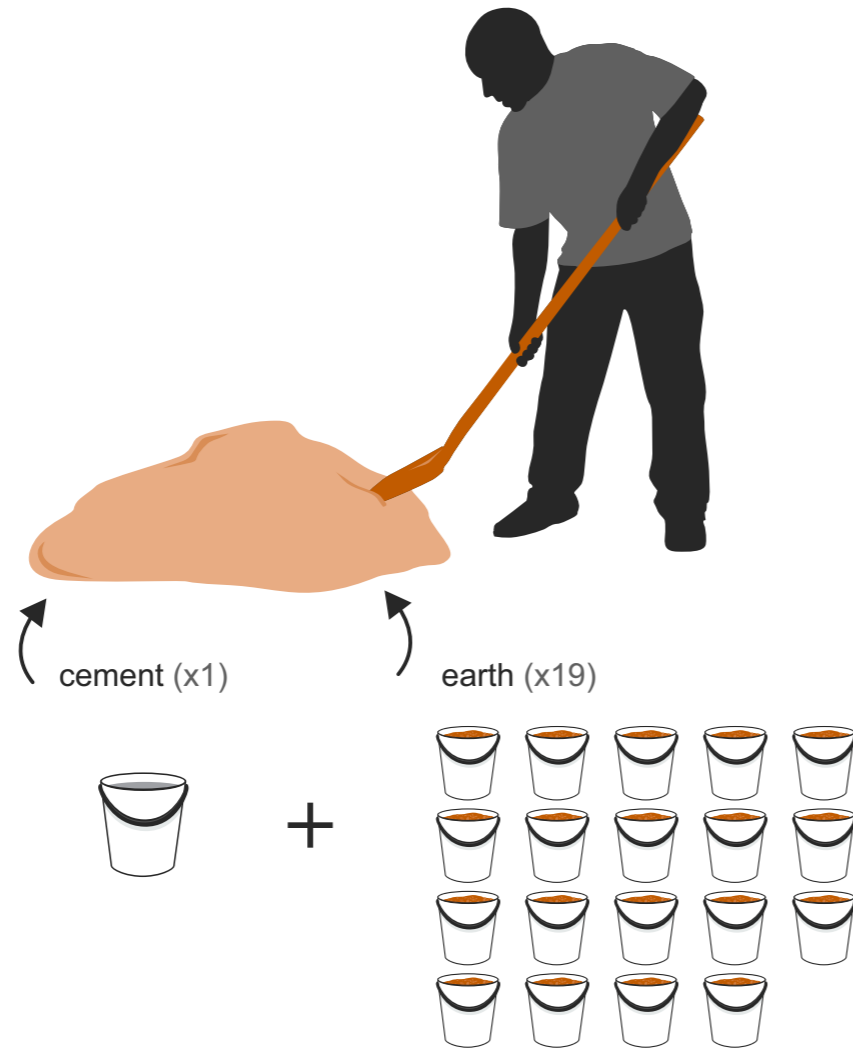

### Pressing the Block

To utilize the machine you must:

- 1 Open the lever.
- 2 Put the soil inside the machine.
- 3 Close the lever.
- 4 Take out the block smoothly and laid down next to the machine in columns.

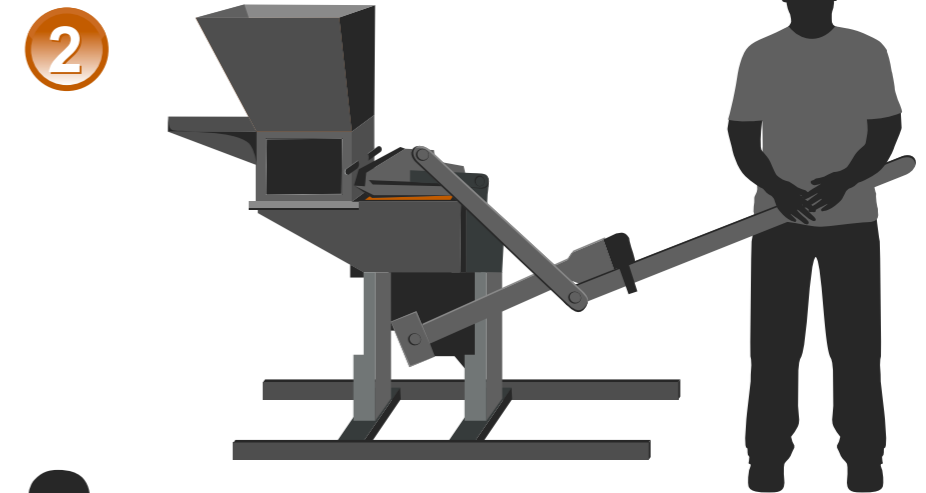
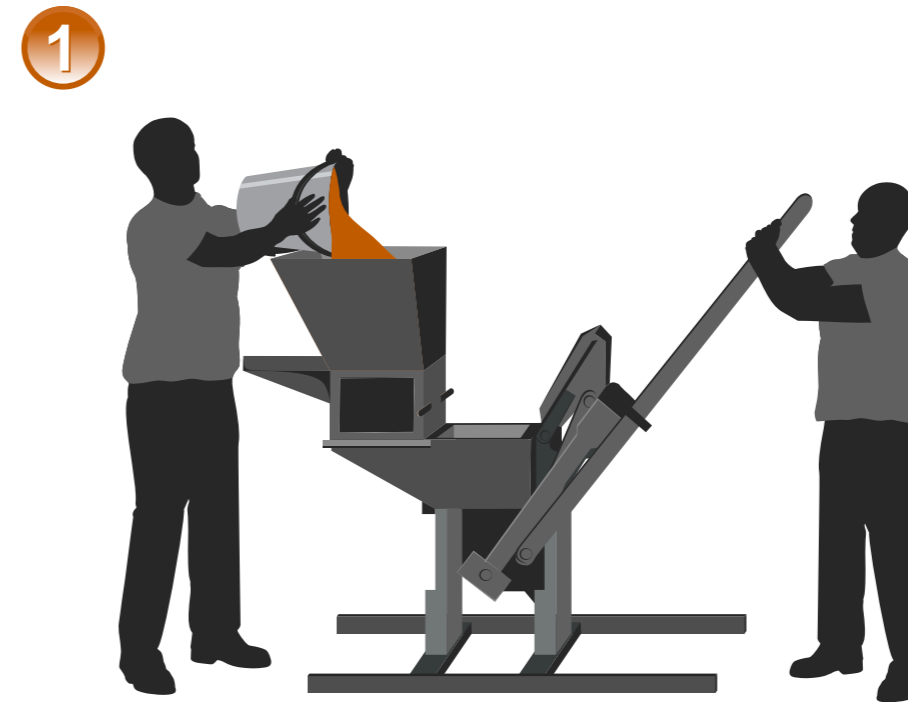

**Storing**

You must stack the blocks a maximum of 7 blocks in height and leave at least 5 cm between each column.

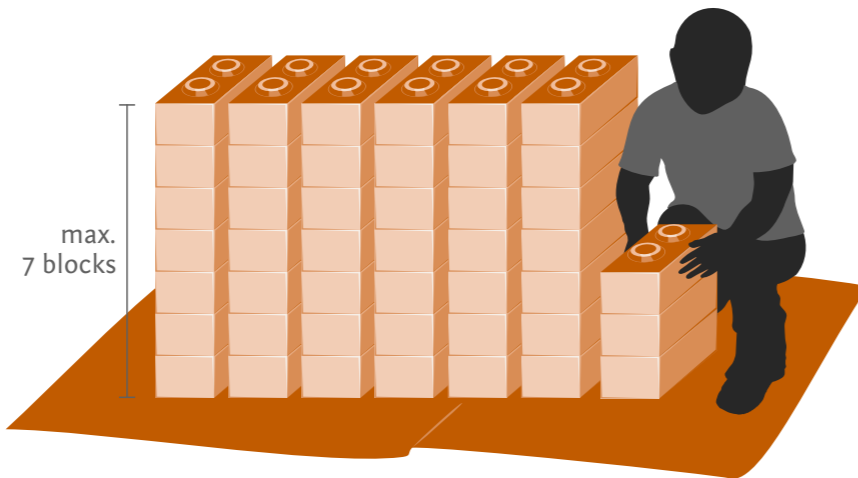

**Curing and Drying**

For curing and drying, you must cover the blocks with a plastic sheet. After 7 days uncover the blocks. After 28 days they are ready for construction!

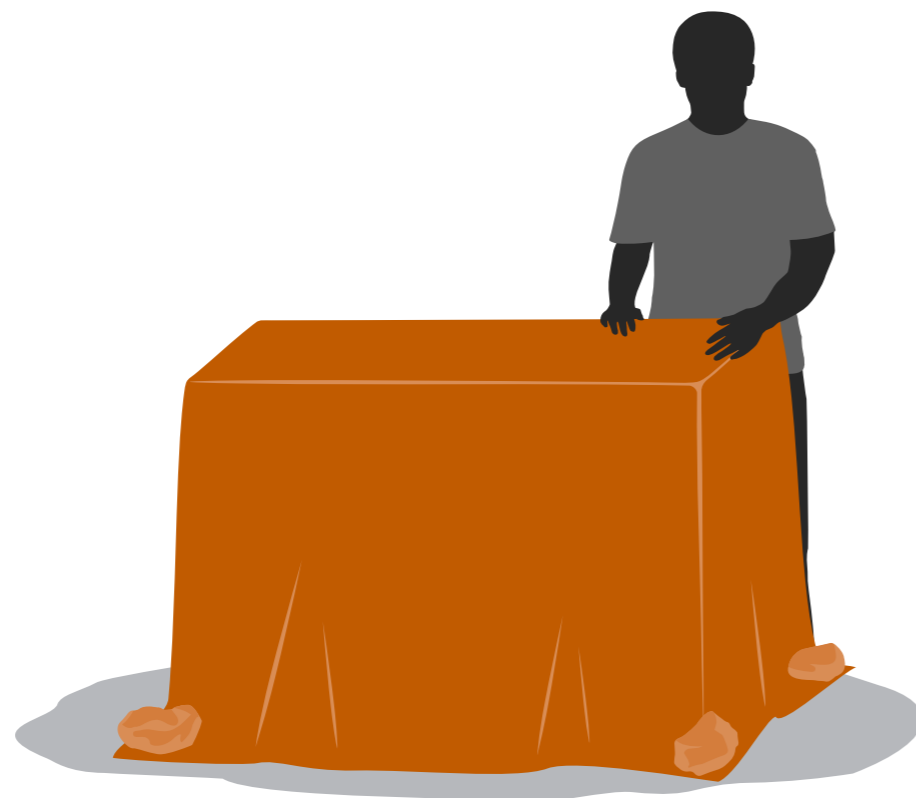

**Testing the Blocks**

To check if you can use the finished blocks you must do this test on three blocks from each production batch.

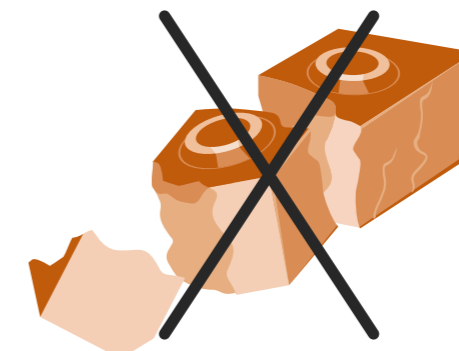
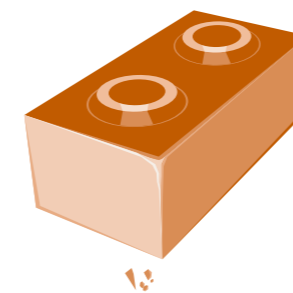
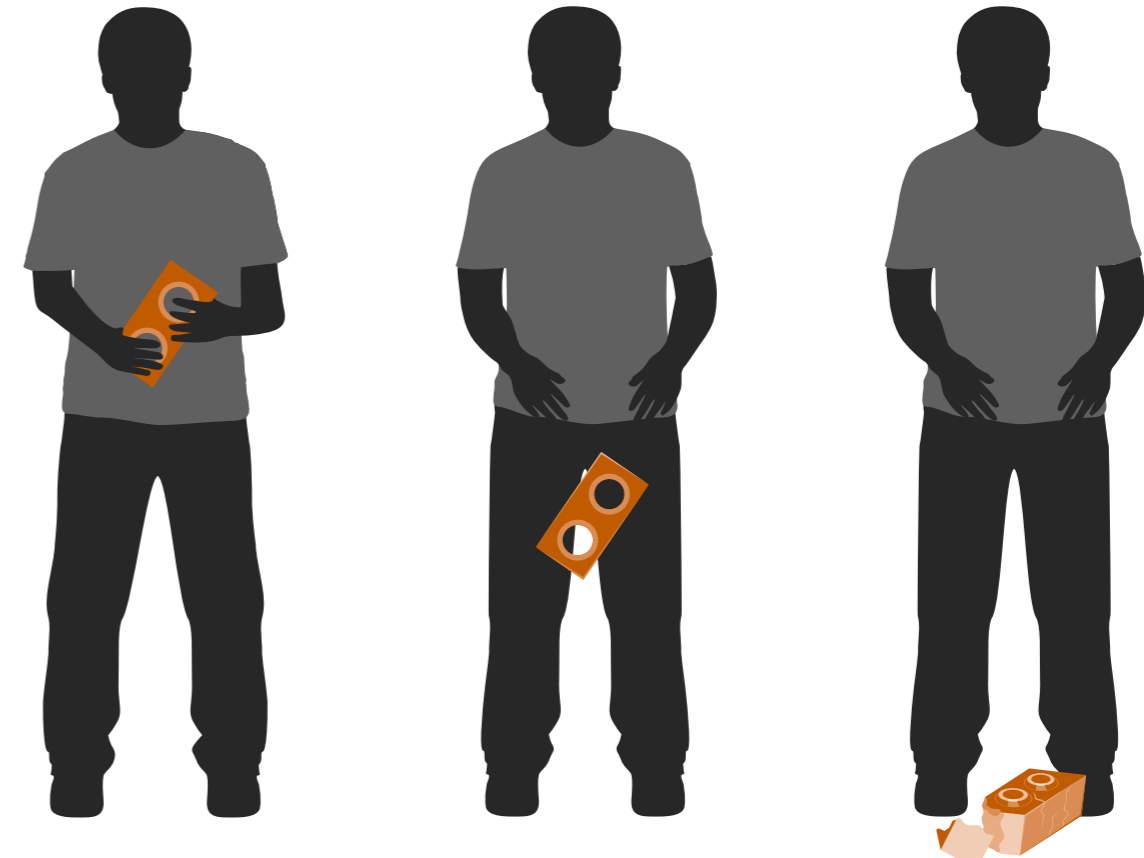

**Block's Results**

If only the tip on which the blocks fell breaks, the blocks are OK!

# HLT hilotec

Self-building Manual  
for Sustainable Housing



University of Minho  
School of Engineering



info: [www.civil.uminho.pt/hilotec](http://www.civil.uminho.pt/hilotec)

# HLT hilotec

Self-building Manual  
for Sustainable Housing

- 1 | Introduction
- 2 | Soil Selection
- 3 | Manufacturing Blocks
- 4 | **Construction of Foundations**
  - 4.2 | Objectives
  - 4.2 | Materials and Tools
  - 4.3 | Construction Working Platform
  - 4.4 | First Marking Steps
  - 4.5 | Second Marking Steps
  - 4.6 | Stacks
  - 4.6 | Dig In
  - 4.7 | Foundation
  - 4.7 | Type of Foundation
  - 4.8 | Type of Foundation
  - 4.9 | Location of Reinforcements
  - 4.9 | Ground Floor
  - 4.10 | 1st Row
  - 4.11 | Reinforcement
- 5 | Building Walls
- 6 | Construction of the Roof



University of Minho  
School of Engineering





**Objectives**

In this Chapter you will learn how to make the foundations for the walls of your house!

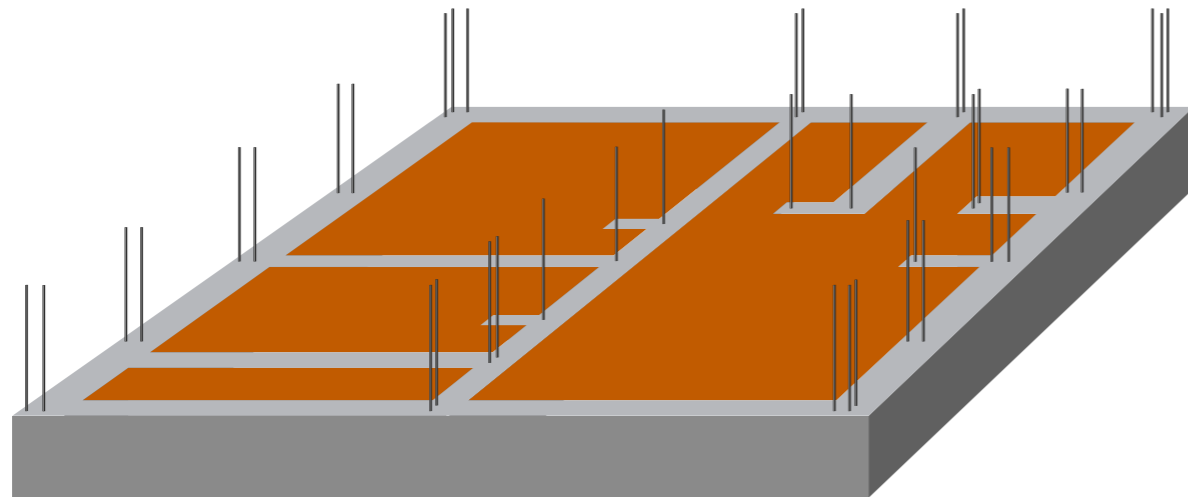

**Materials and Tools**

These are the materials and tools that you will need in this phase:  **cords, tape, some wood, steel rods of 8mm, transparent hose, shovel, hoe, compactor and material for foundations.**



**Construction Working Platform**

- 1 Take a transparent hose with more or less 10 m.
- 2 Put clean water inside the hose.
- 3 Measure the height H1 and H2 from the ground.
- 4 Subtracting H1 from H2 you will get the depth that you have to dig or fill

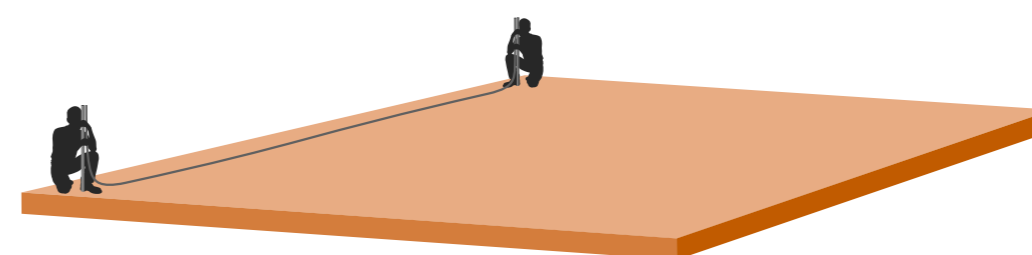
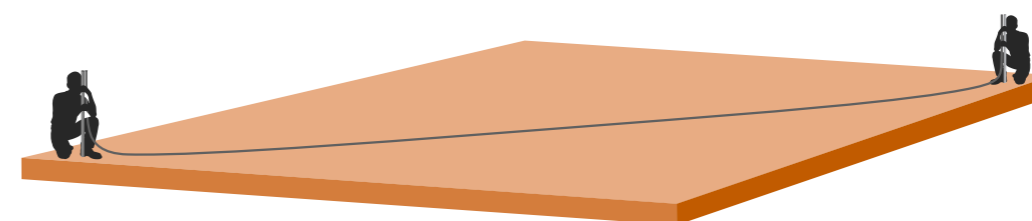
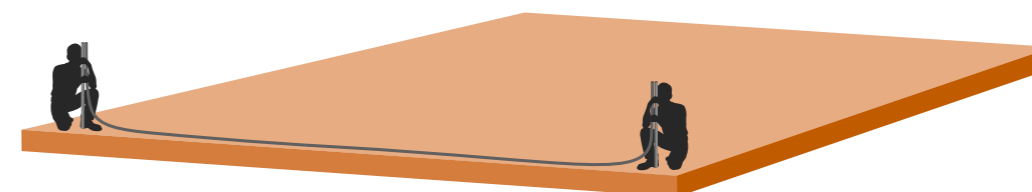
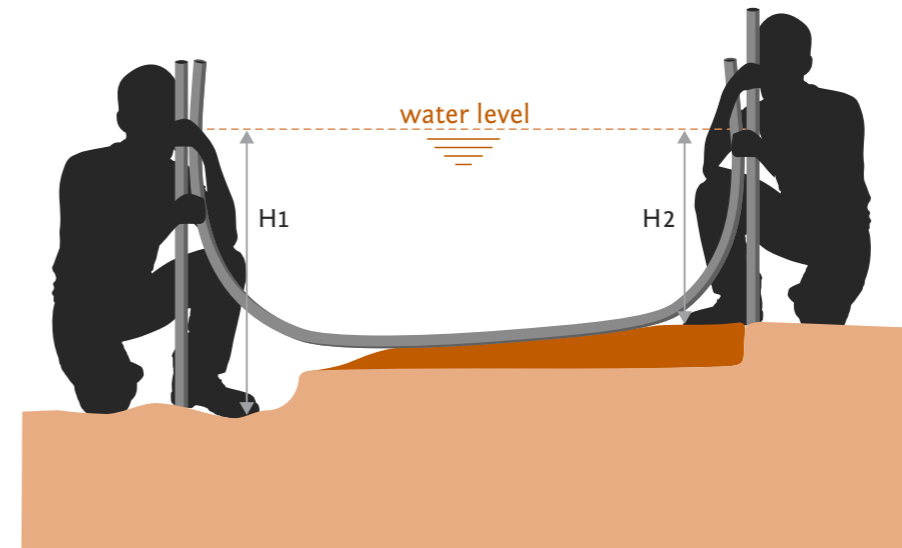

First Marking Steps

1 Mark point 1 with a stake at the recommended distance, **D**, from the street, given by the local authorities.

2 Mark point 2 at **D** meters from the road and 7 m from point 1.

3 Mark 6 m between point 1 and 2. Then mark one perpendicular line of 8 m. The length of the diagonal must be 10 m.

4 From the auxiliary line, mark point 3 at a distance of 7,98 m from point 1.

5 Repeat the process of step 3 at point 2 and mark point 4.

6 Check the diagonals. The diagonals must have a length of 10,62 m.

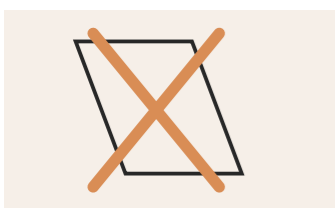
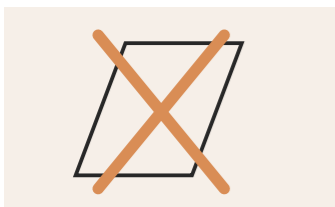
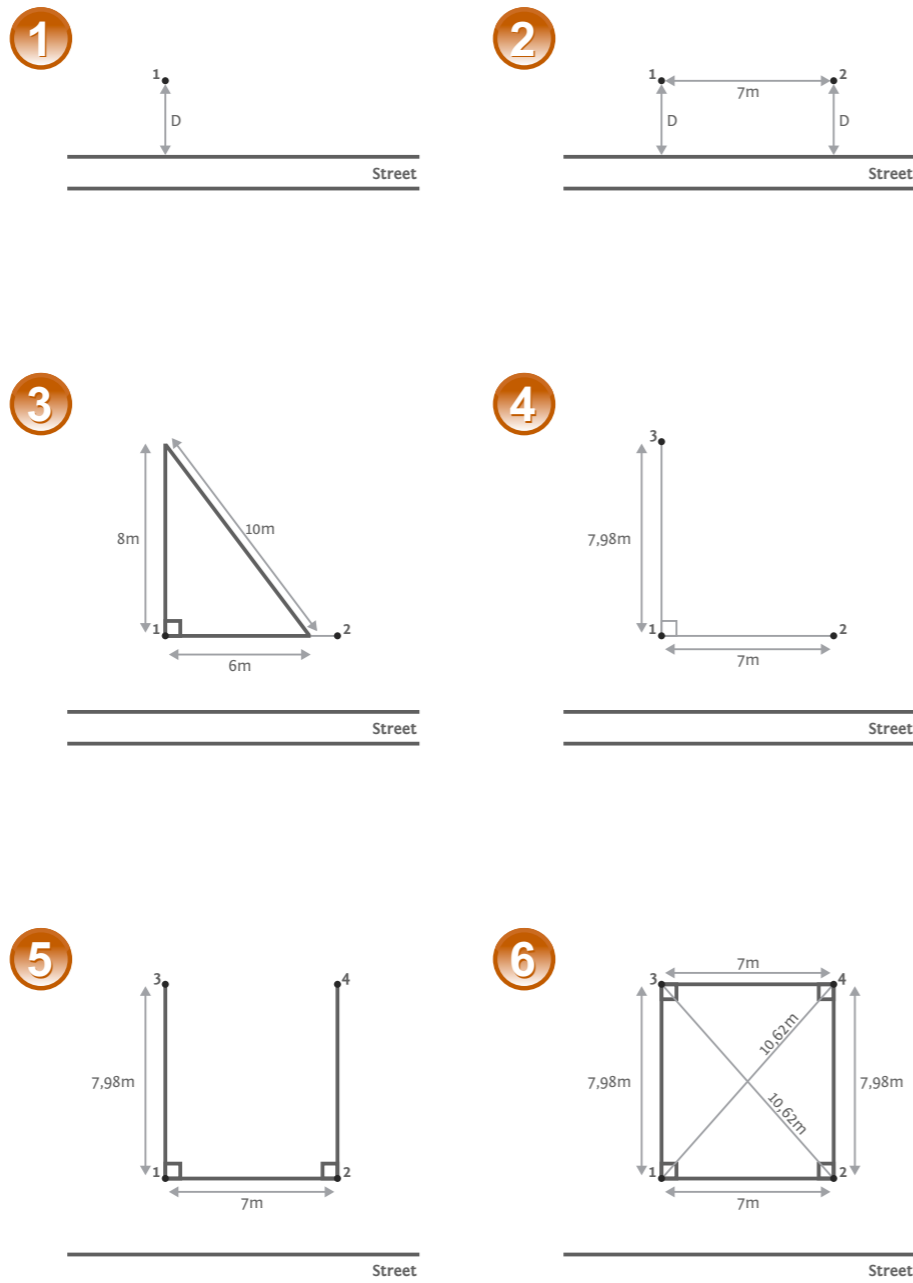
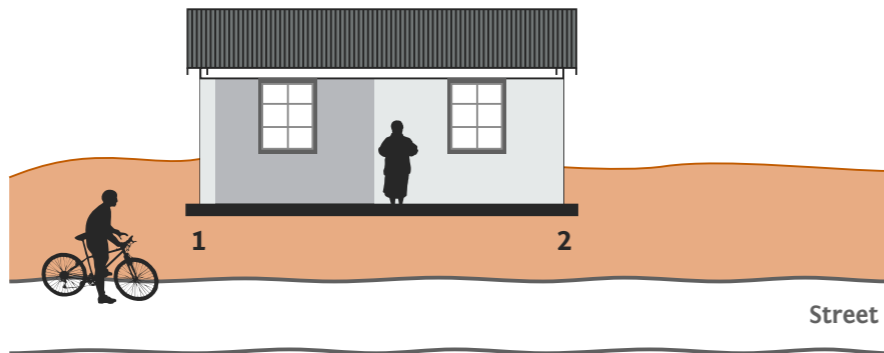

Second Marking Steps

Stretch the cords between the stakes to mark the outline of the walls. Then mark parallel to the cords the edges of the foundations with the chalk rope on the ground. Make sure that the distance of the marked lines towards the nearest cord is always the same.

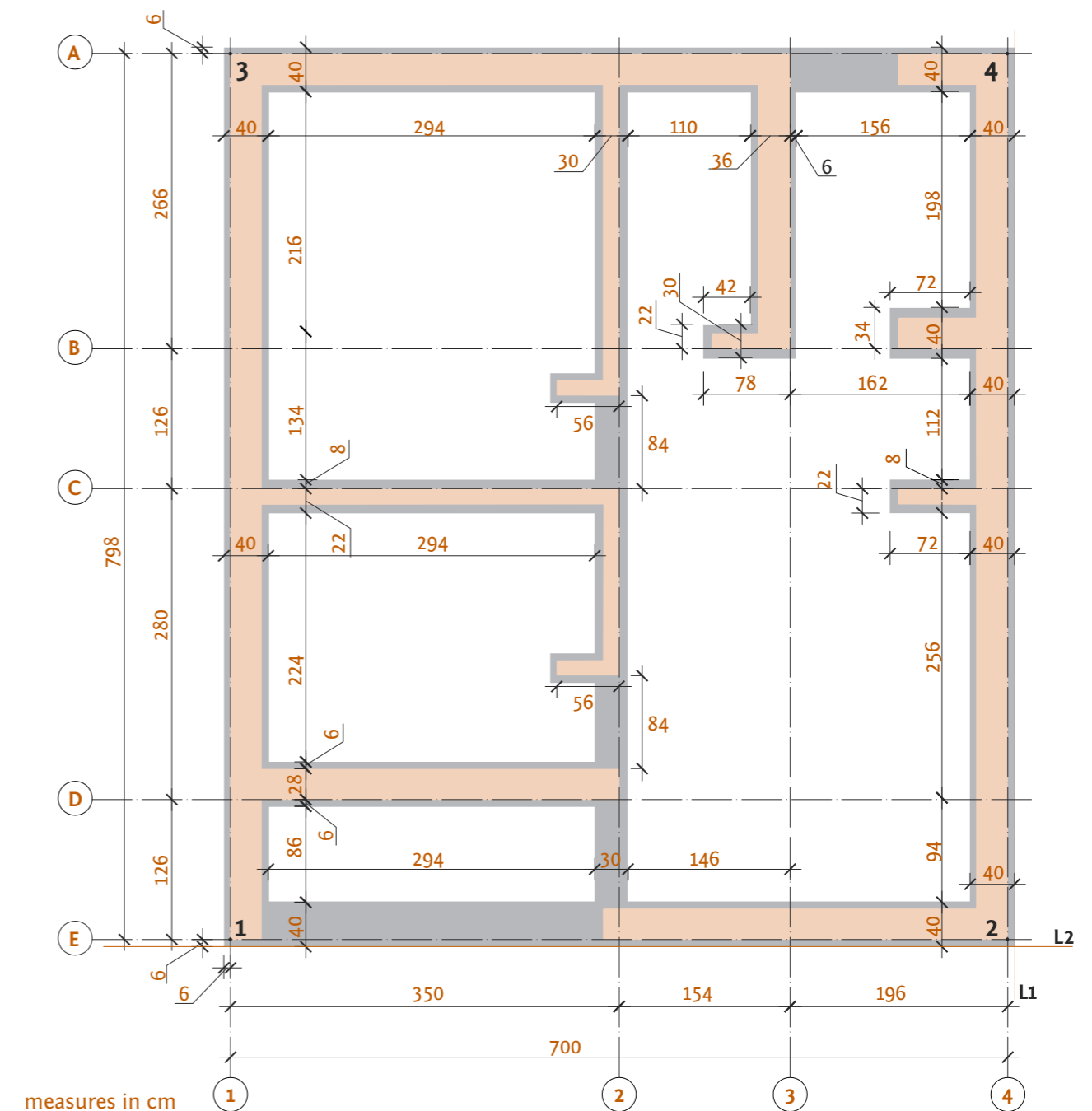

**Stakes**

This is how your marking should look like before you start digging.

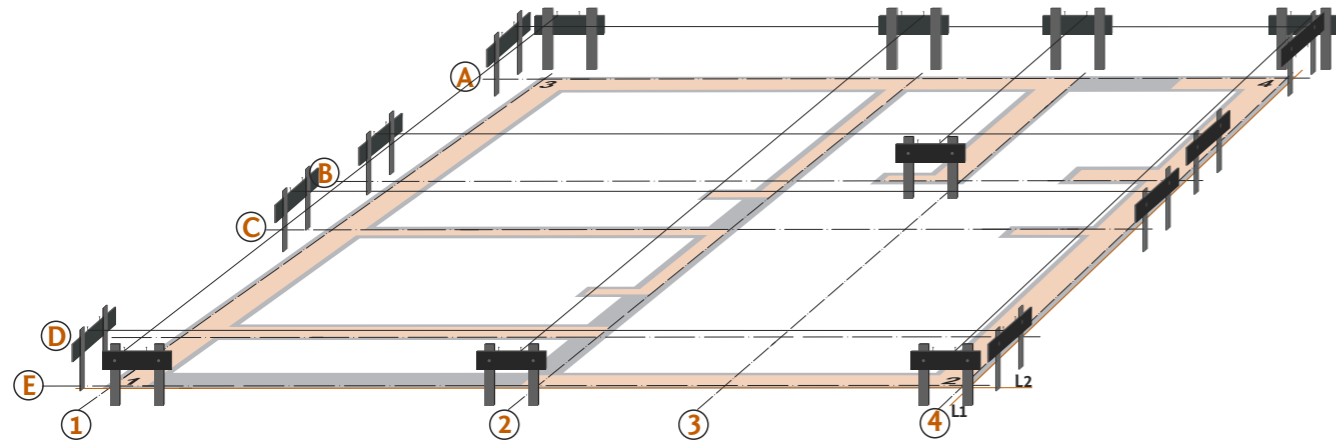

**Digging**

Now it's time to dig!  
You can remove the ropes during this task to be more comfortable, as long as you **don't** move the stakes.

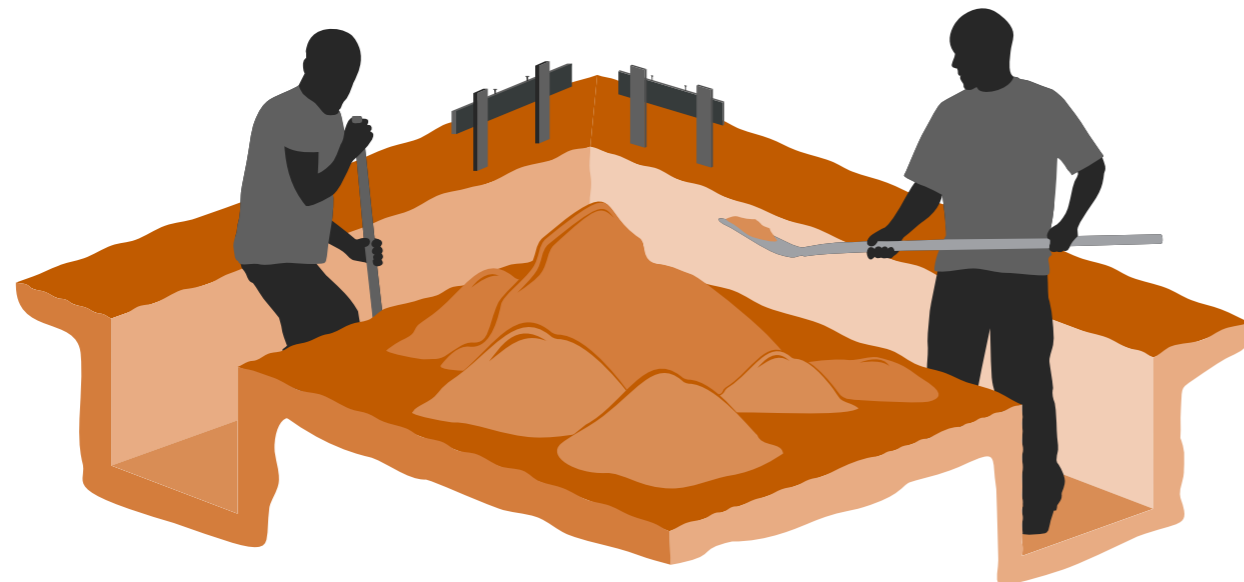

**Foundation**

The foundation will protect your house from floods and moisture damp.  
Pay attention to details.

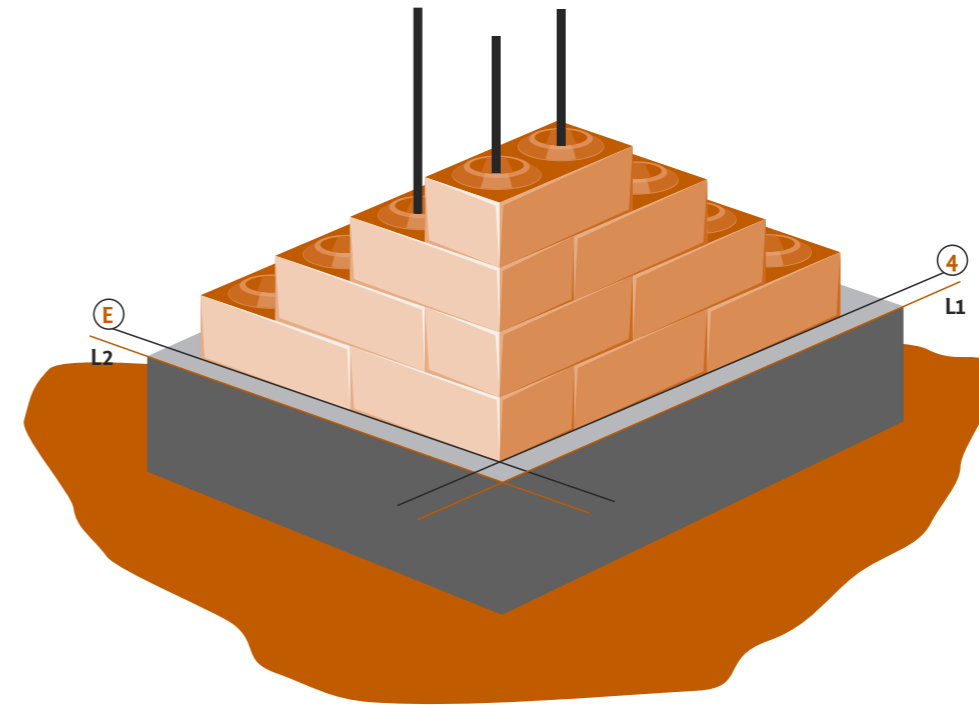

**Type of Foundation**

You can choose which kind of foundation you will use, but please respect the dimensions and levels.

**Poor Concrete**

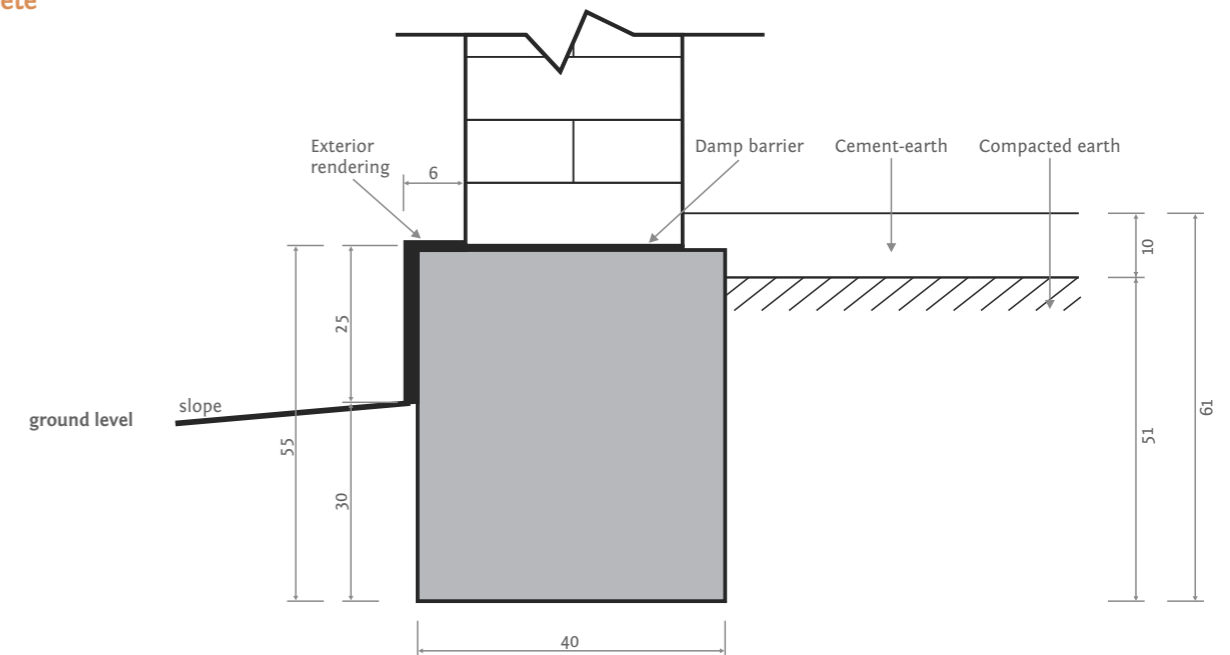

measures in cm

Type of Foundation (cont.)

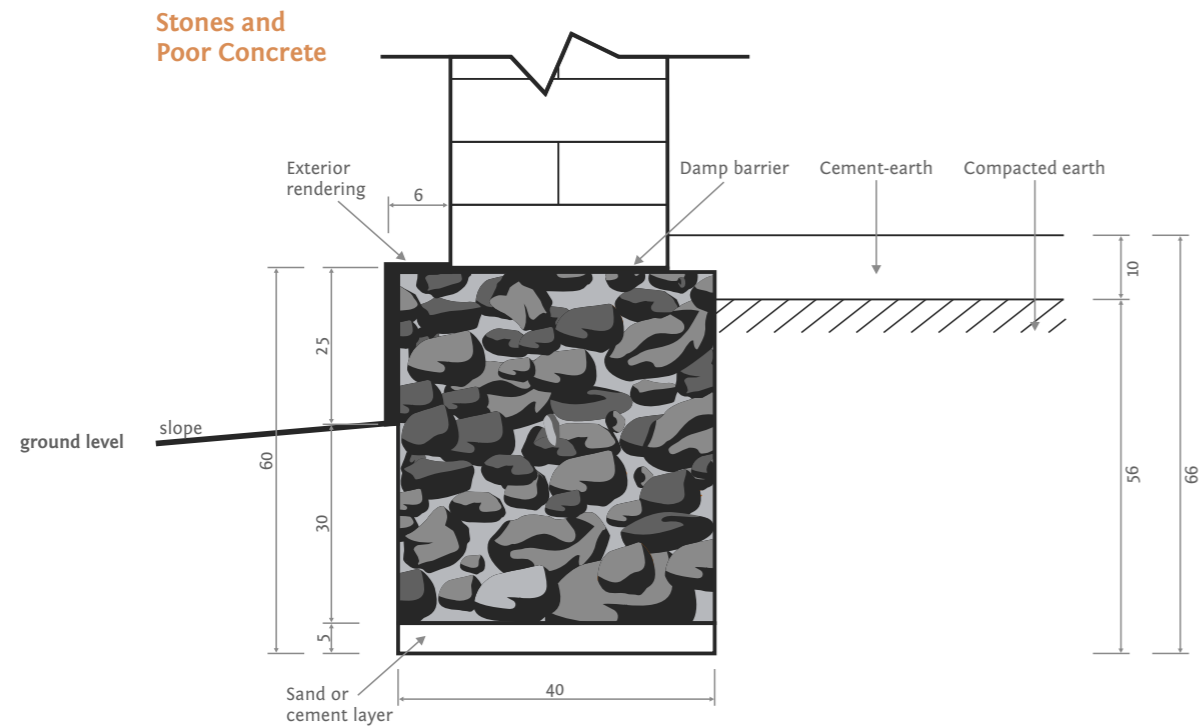
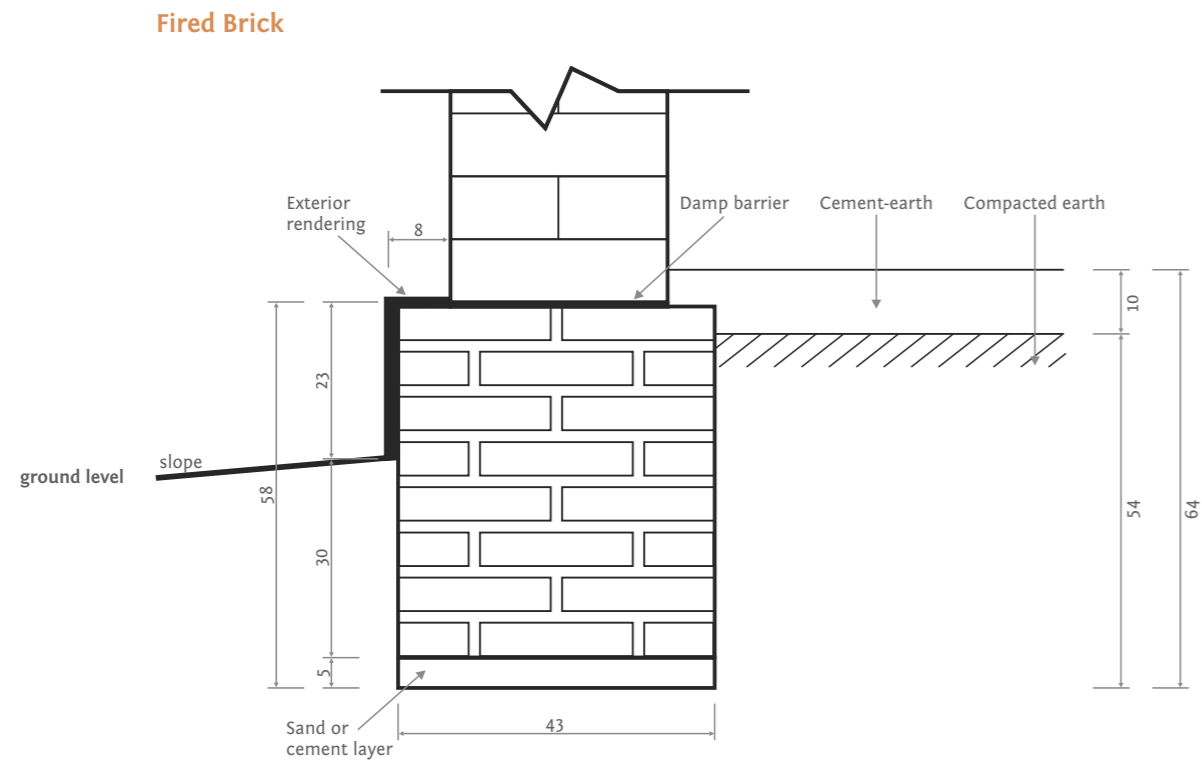

measures in cm

Location of reinforcements

Reinforcements must be placed in the correct points.

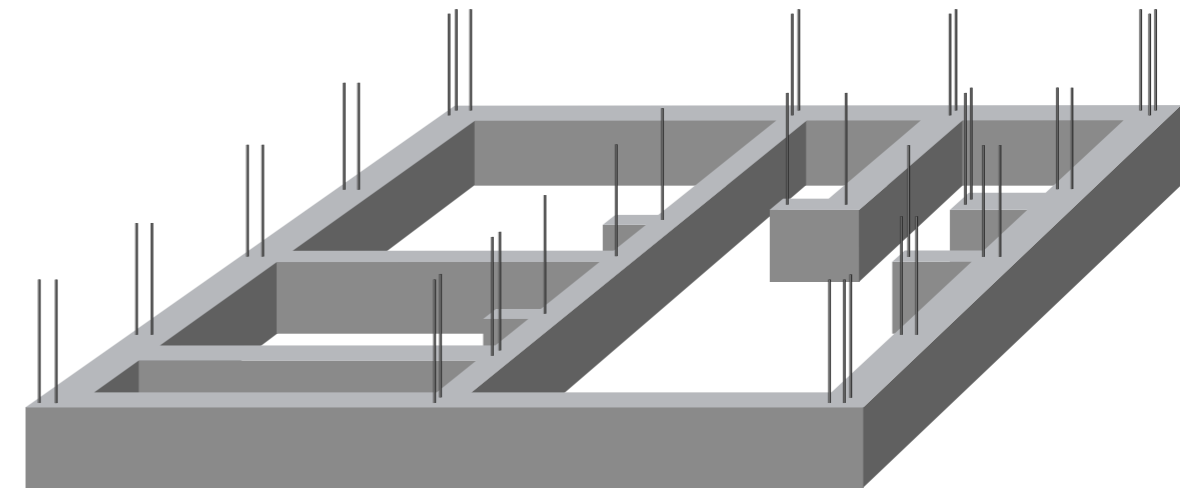

Ground Floor

You need to compact the soil inside the house very well before making the pavement. You can use for your pavement the same soil cement mixture you used to produce the blocks. Make sure to compact the soil cement mix again for the pavement while it is fresh.

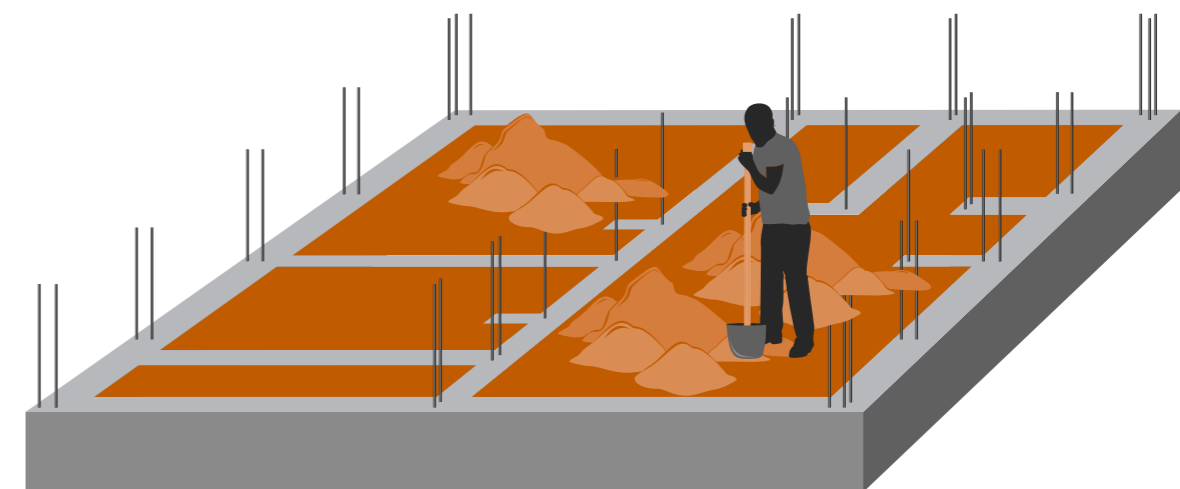

1<sup>st</sup> Row

Location of the reinforcements.

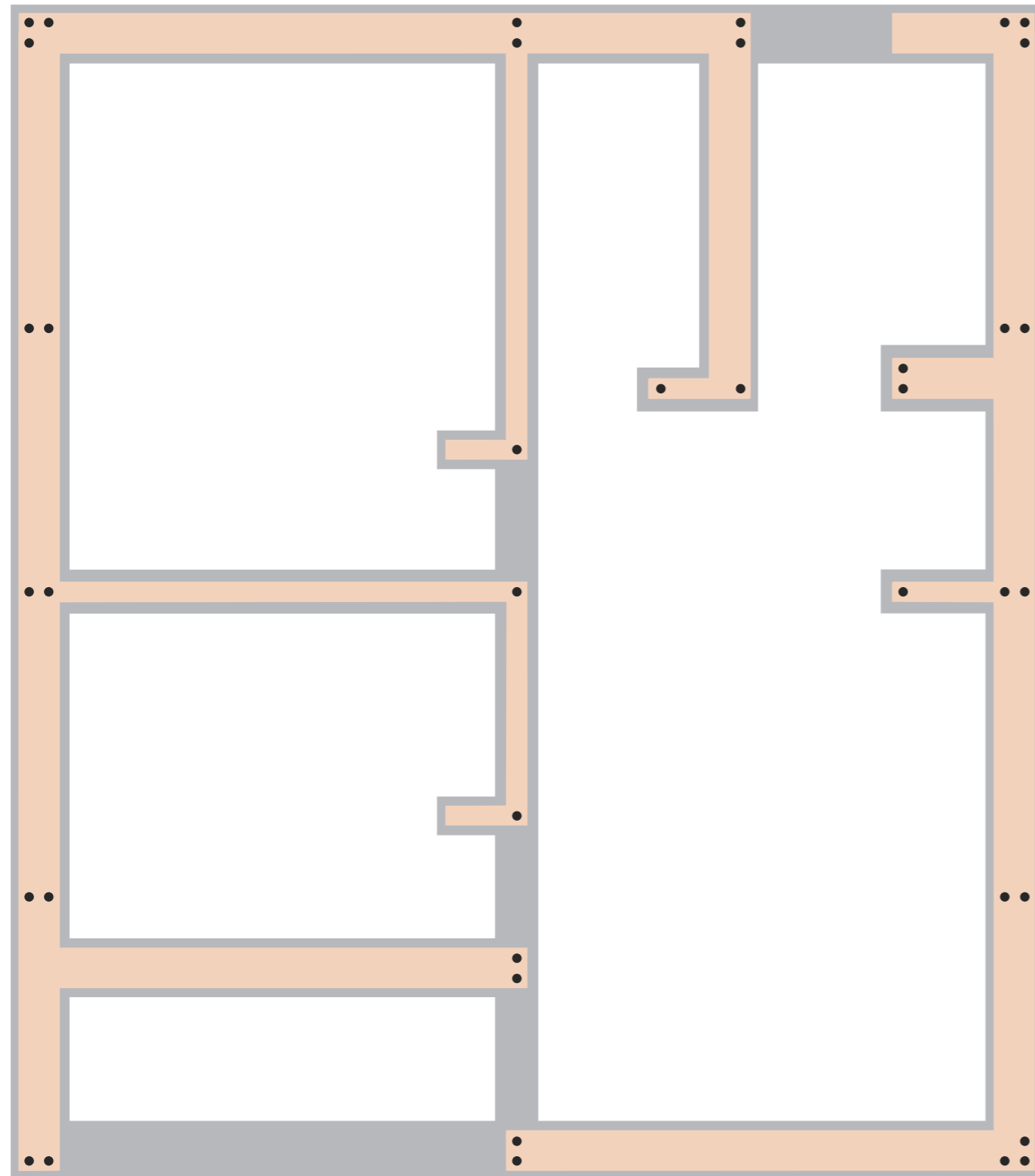
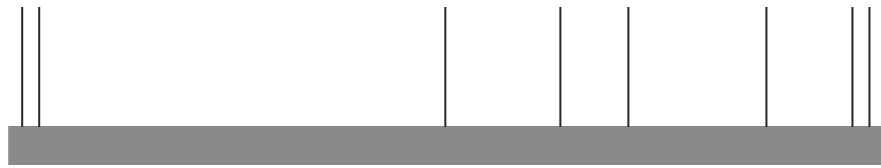

Reinforcement

Location of the first row of blocks with reinforcements.

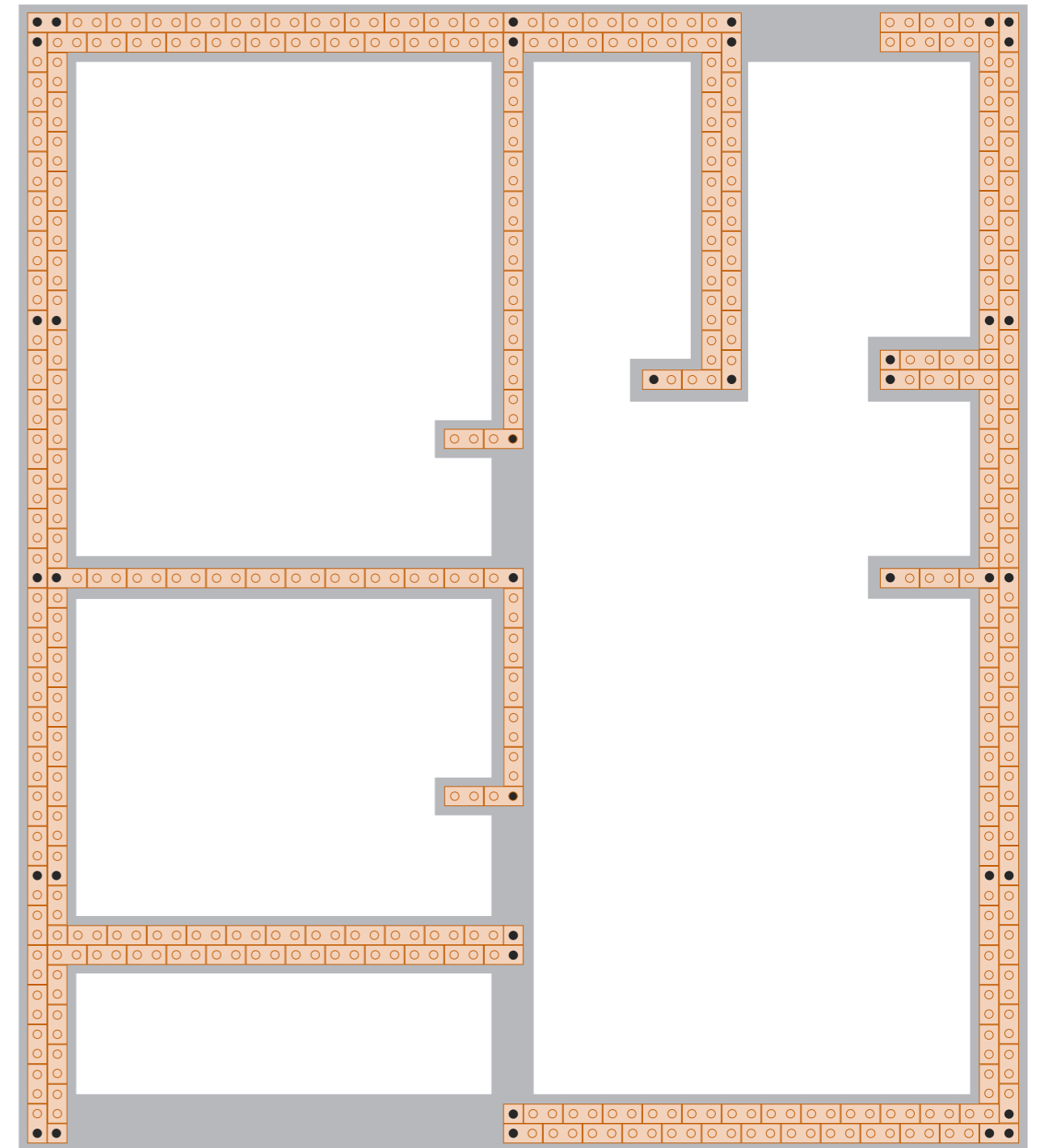
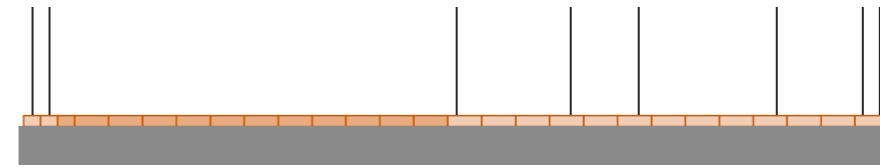



# HLT hilotec

Self-building Manual  
for Sustainable Housing



University of Minho  
School of Engineering



info: [www.civil.uminho.pt/hilotec](http://www.civil.uminho.pt/hilotec)

# HLT hilotec

Self-building Manual  
for Sustainable Housing

- 1 | Introduction
- 2 | Soil Selection
- 3 | Manufacturing Blocks
- 4 | Construction of Foundations
- 5 | Building Walls
  - 5.2 | Objectives
  - 5.2 | Materials and Tools
  - 5.3 | Damaged Blocks
  - 5.4 | 1st Row
  - 5.5 | 2nd Row
  - 5.6 | Construct the Walls
  - 5.6 | Corners
  - 5.7 | Meeting of Walls
  - 5.7 | Corners
  - 5.8 | Reinforcement
  - 5.9 | Horizontal Course
  - 5.10 | Construction of Windows
  - 5.11 | Last Row before concrete
  - 5.11 | Reinforcement of Ring Beam
  - 5.12 | Concrete Mixture and Formwork
  - 5.13 | Concrete Formwork
- 6 | Construction of the Roof



University of Minho  
School of Engineering



**Objectives**

In this Chapter you will learn how to build the walls of your house!

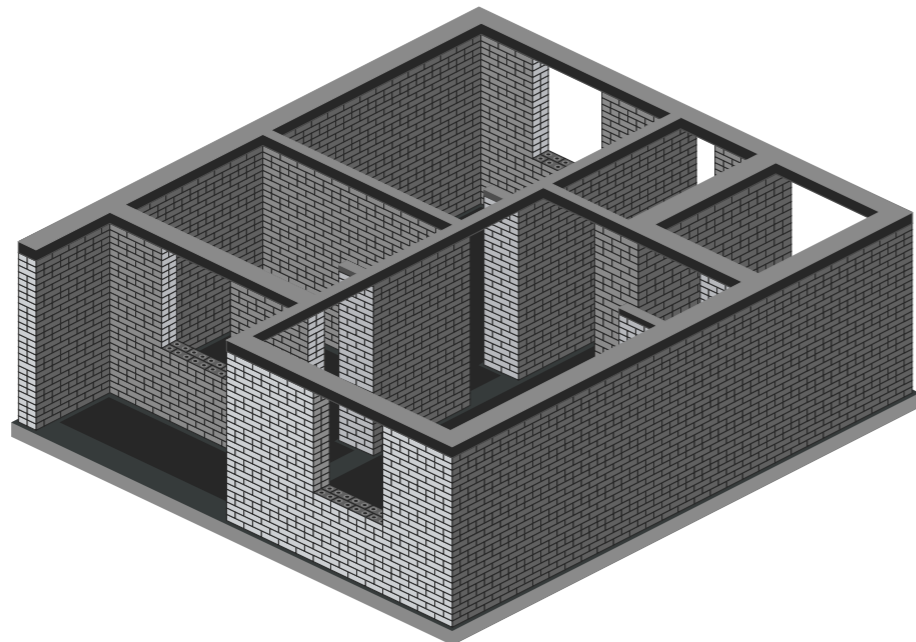

**Materials and Tools**

These are the materials and tools that you will need in this phase: **cement, wire, sand, gravel, wood for formwork, staples, water, some paper or newspaper and the blocks.**

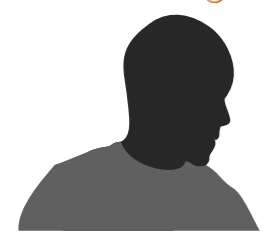
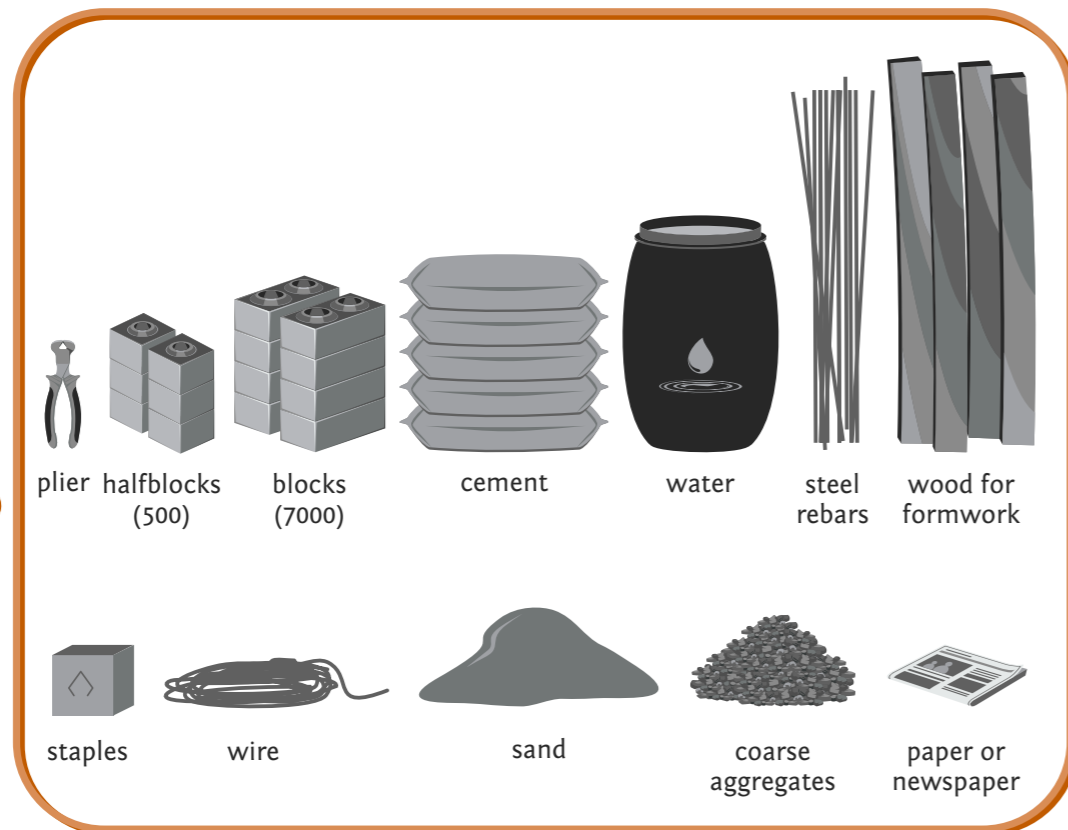

**Damaged Blocks**

Do not use damaged blocks to build your house!

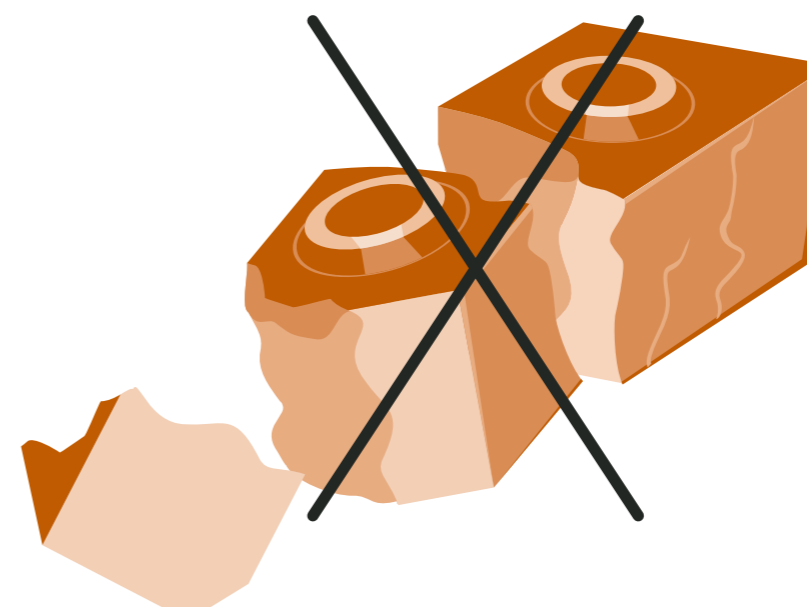
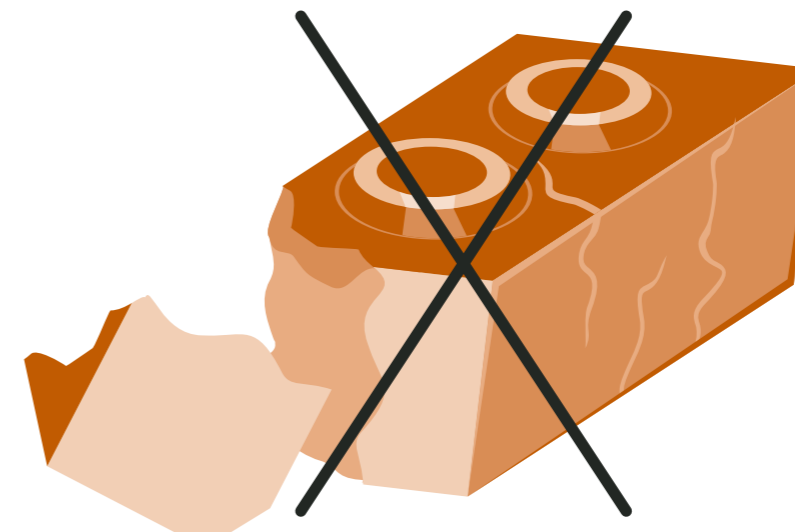

1<sup>st</sup> Row

The first row of the walls is **very important** for the construction of the house! The exact geometry of this row will help to laid down the upper blocks in courses, avoiding cracks, and helping the passage of steel rebars through the holes.

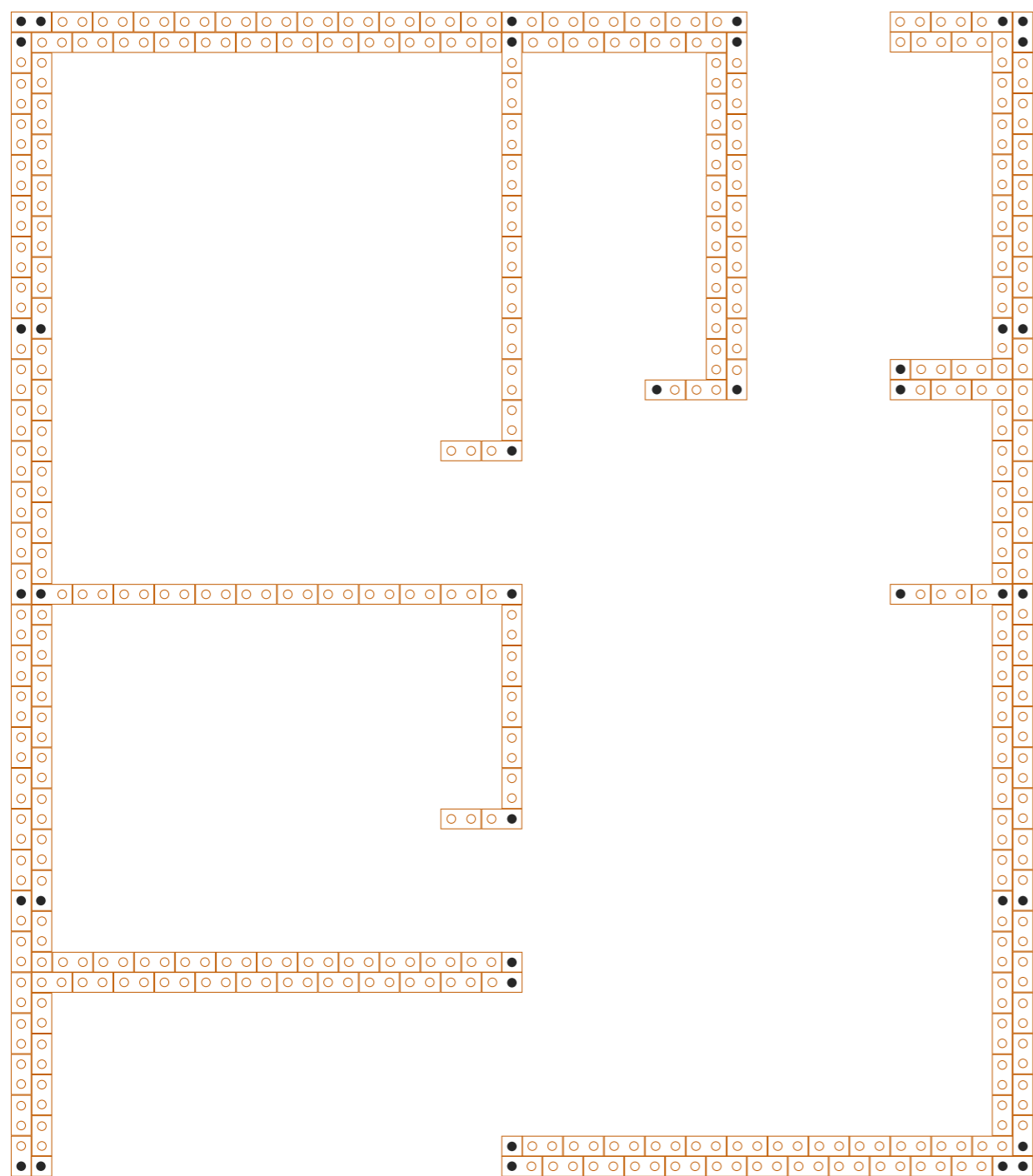
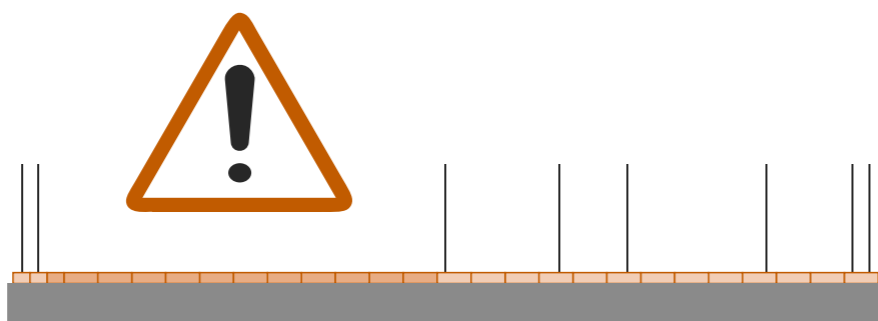

2<sup>nd</sup> Row

Then comes the second row...

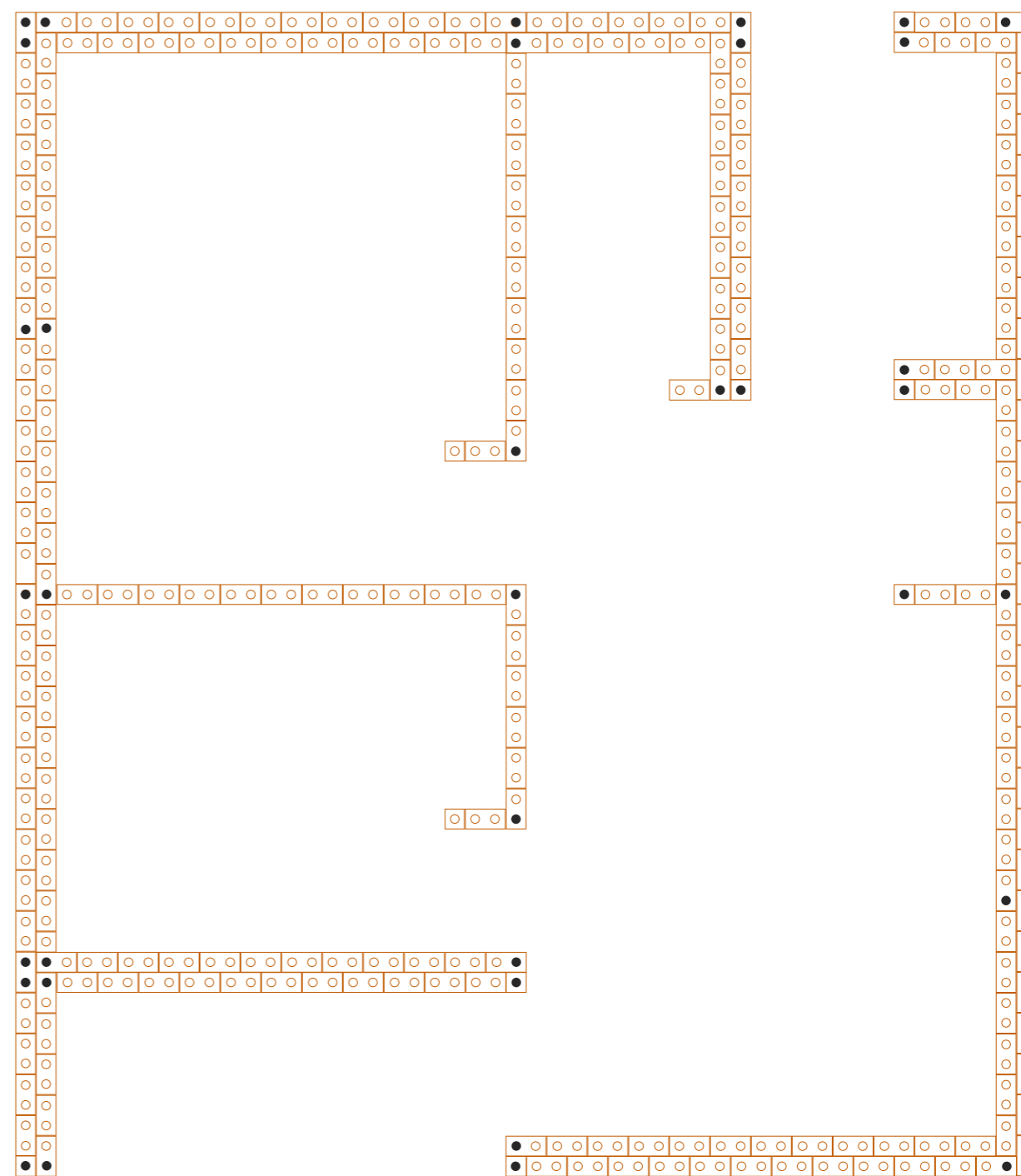
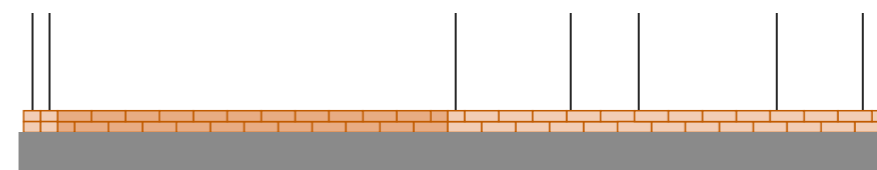

### Construct the Walls

To construct the walls correctly, it's very important that the blocks follow the pattern.

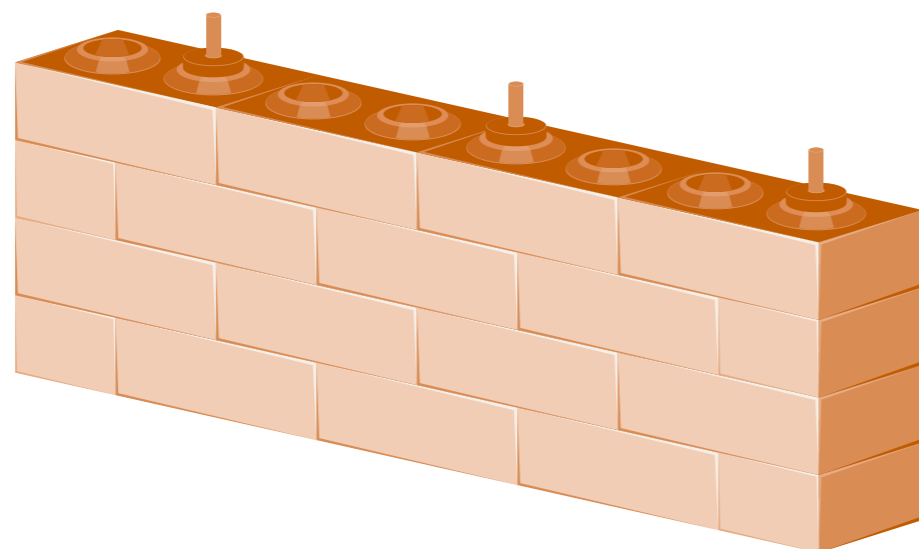

### Corners

Corners for division walls with reinforcements.

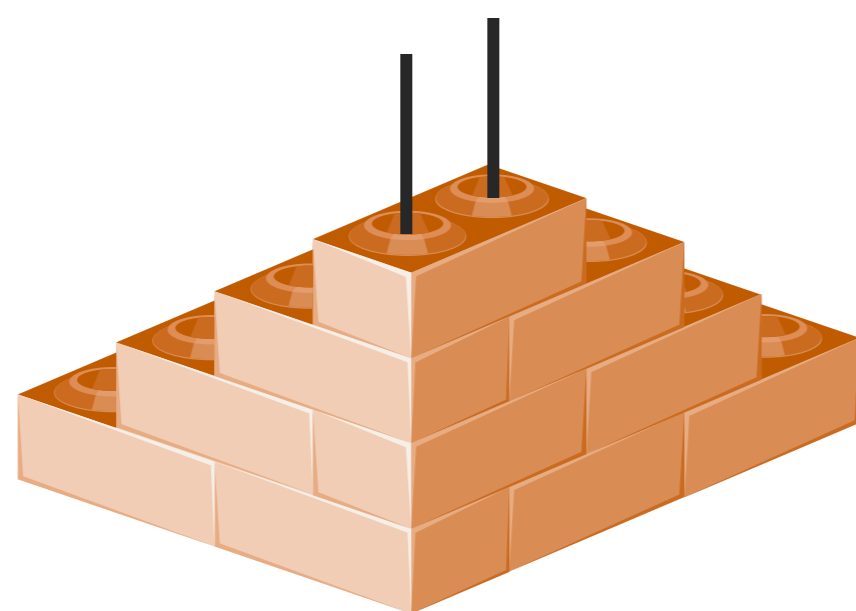

### Meeting of walls

Meeting of division walls.

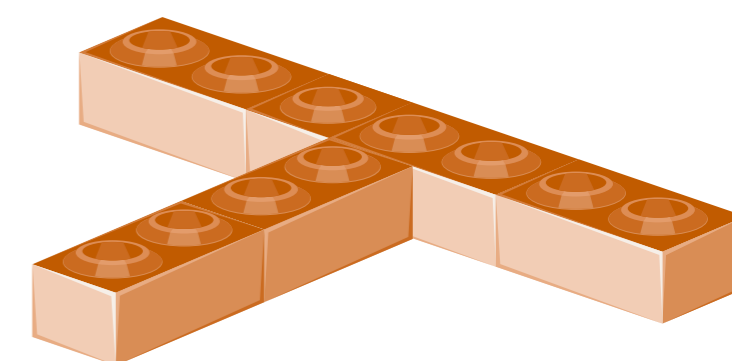
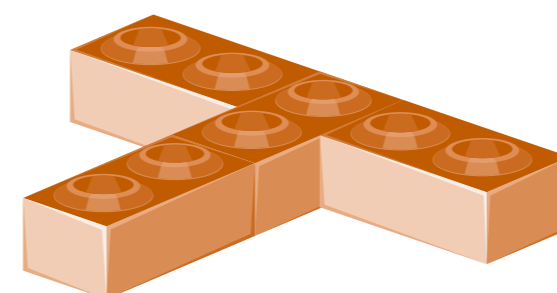

### Corners

Corners for division walls.

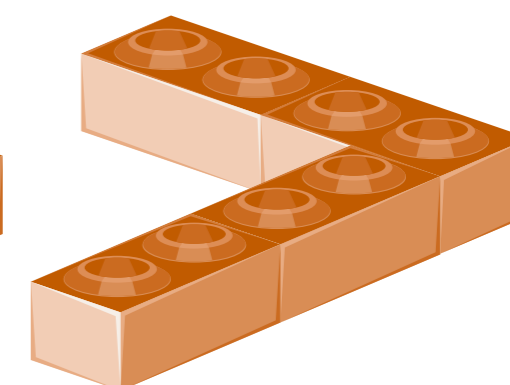
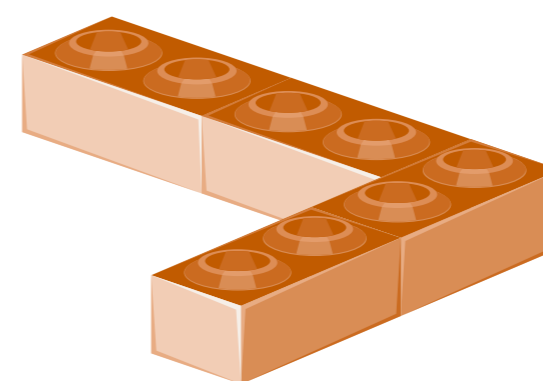

**Reinforcement**

In the spots marked in the plan you will place the steel reinforcement rebars for your house.

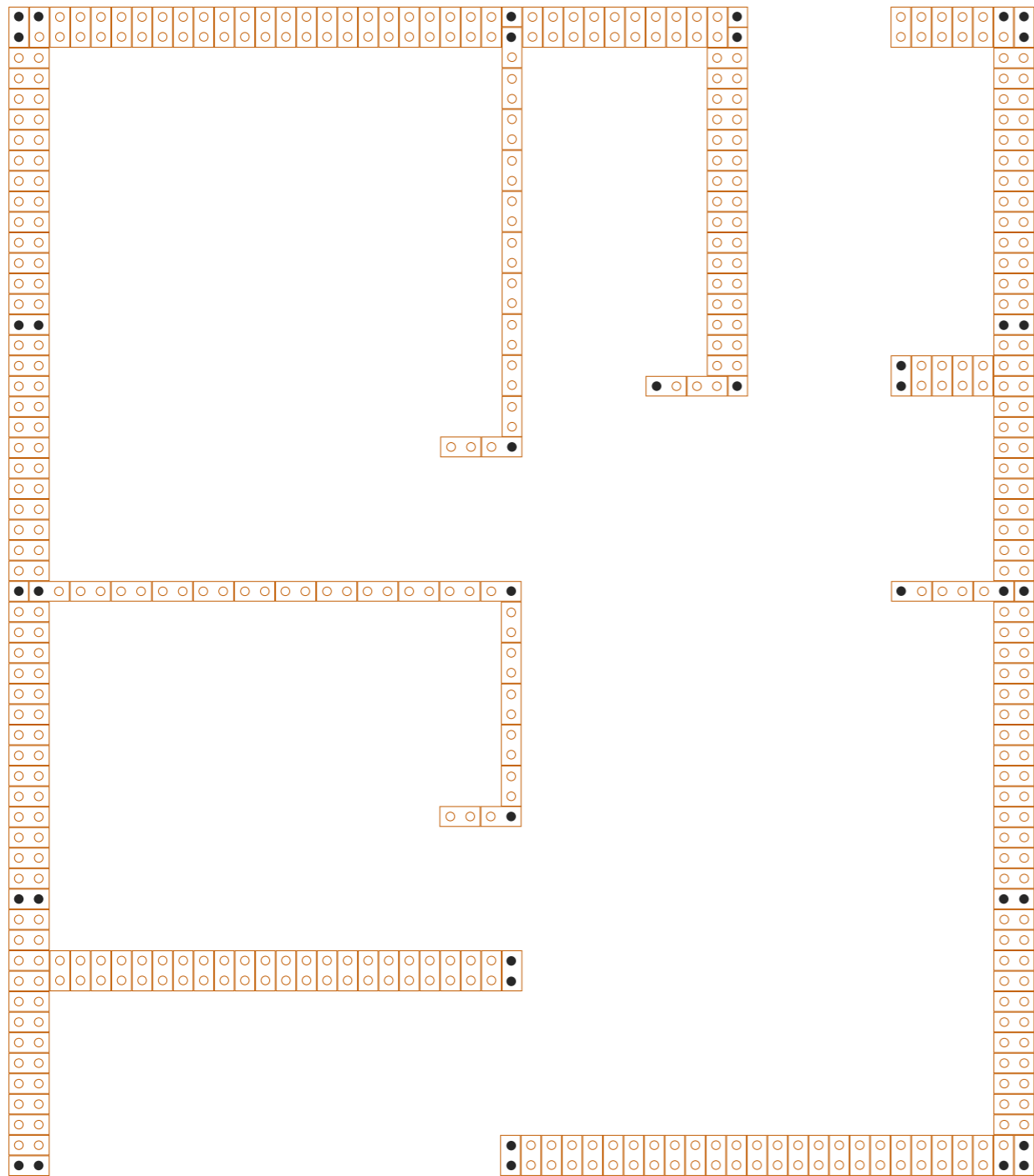
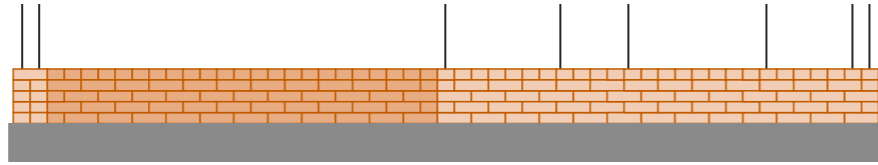

**Horizontal Course**

Every 5<sup>th</sup> row you must lay a horizontal course perpendicular to the wall!

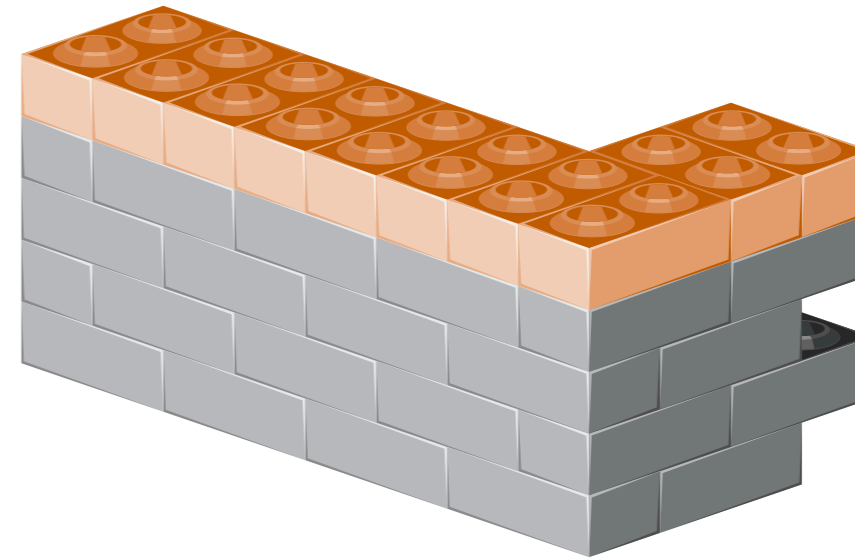

**Horizontal Course**

Pay attention to the locations of the perpendicular rows!

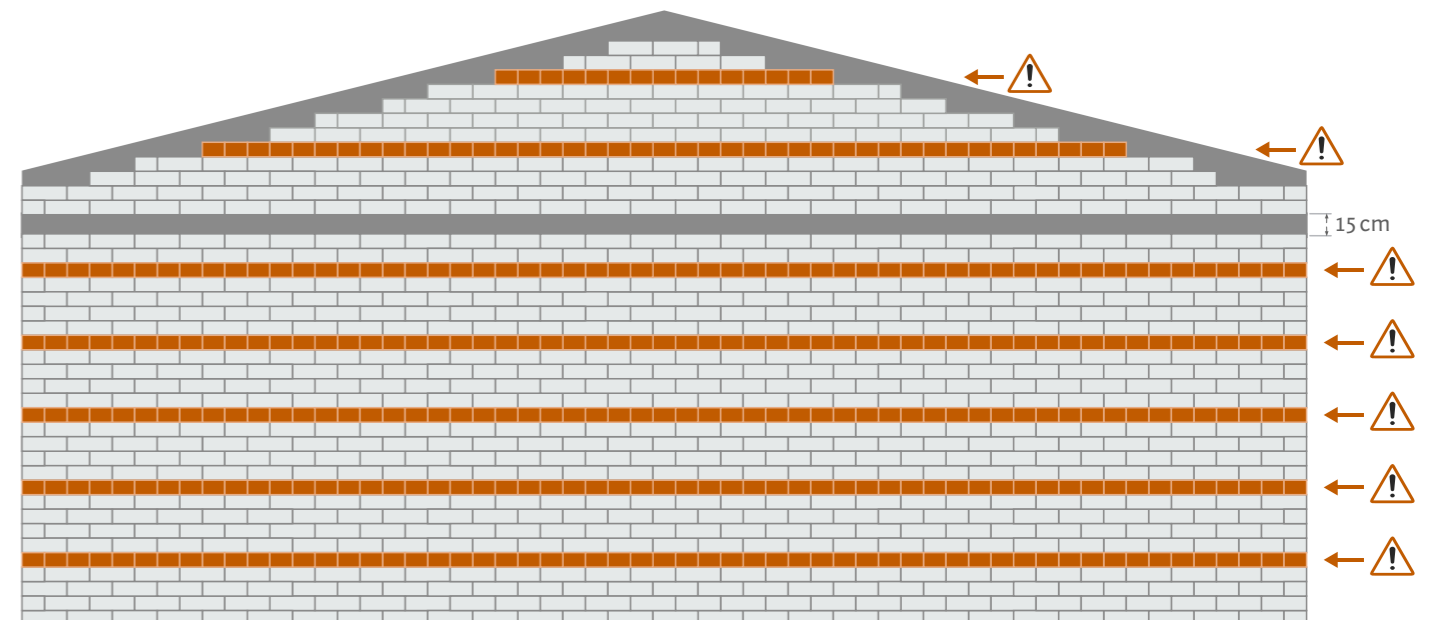



Construction of Windows

The windows of your house should start at the 12<sup>th</sup> row and go until the top of the masonry walls.

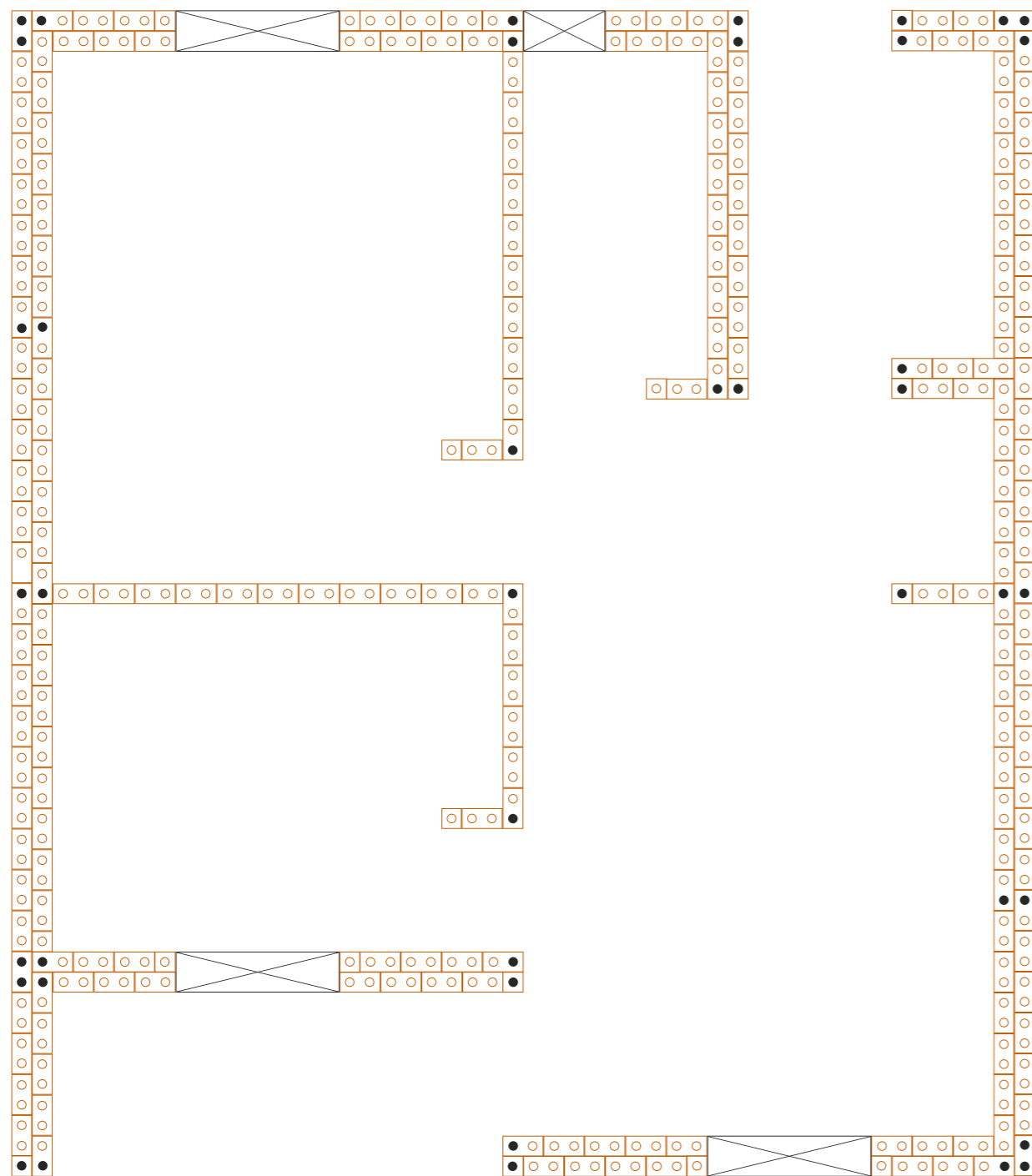
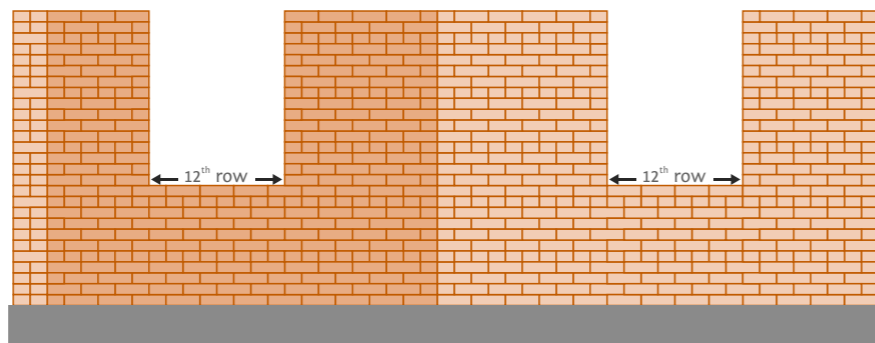

Last Row before concrete

Seal each hole, which has no steel bar, tightly with paper or newspaper to save concrete. **Don't** seal the holes with steel rebars!

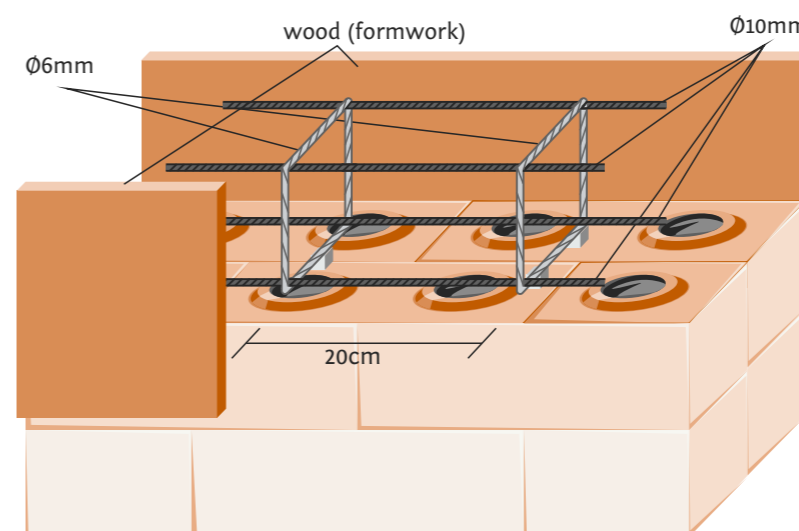
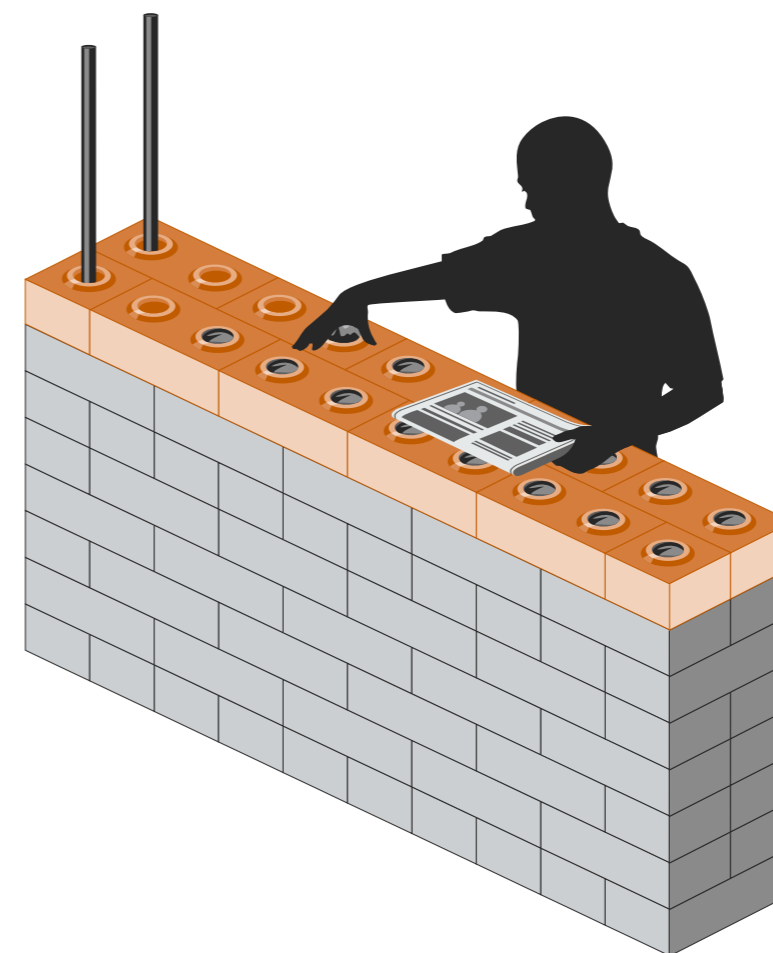

Reinforcements of ring beam

The longitudinal reinforcements of the ring beam are of 10mm diameter, while the stirrups are of 6mm steel rebars laid every 20cm.

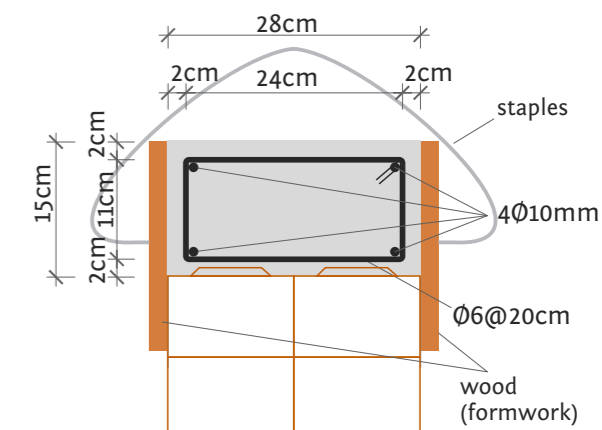

### Concrete Mixture and Formwork

To make the concrete use the following ratio: 1 part of cement, 2 parts of sand, and 3 parts of coarse aggregates. Add the necessary water to mix well.

Before pouring the concrete into the ring beam's formwork, make sure that the reinforcements have been laid in place.

Shake the concrete with a rod, to eliminate possible air bubbles in the concrete.

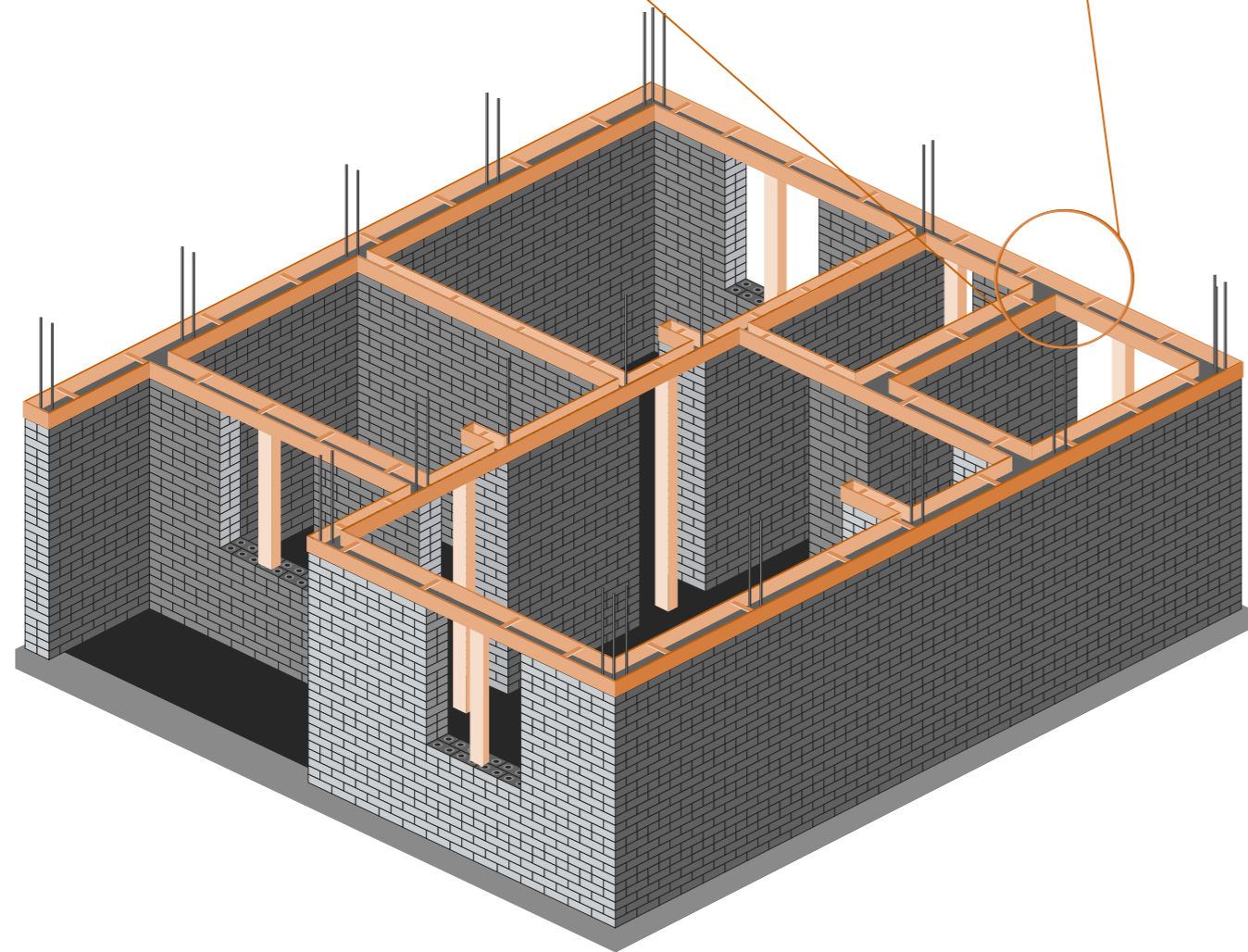

### Concrete Formwork

The formwork can be taken off after 7 days of curing. During this 7 days period, the concrete should remain covered by plastic sheets.

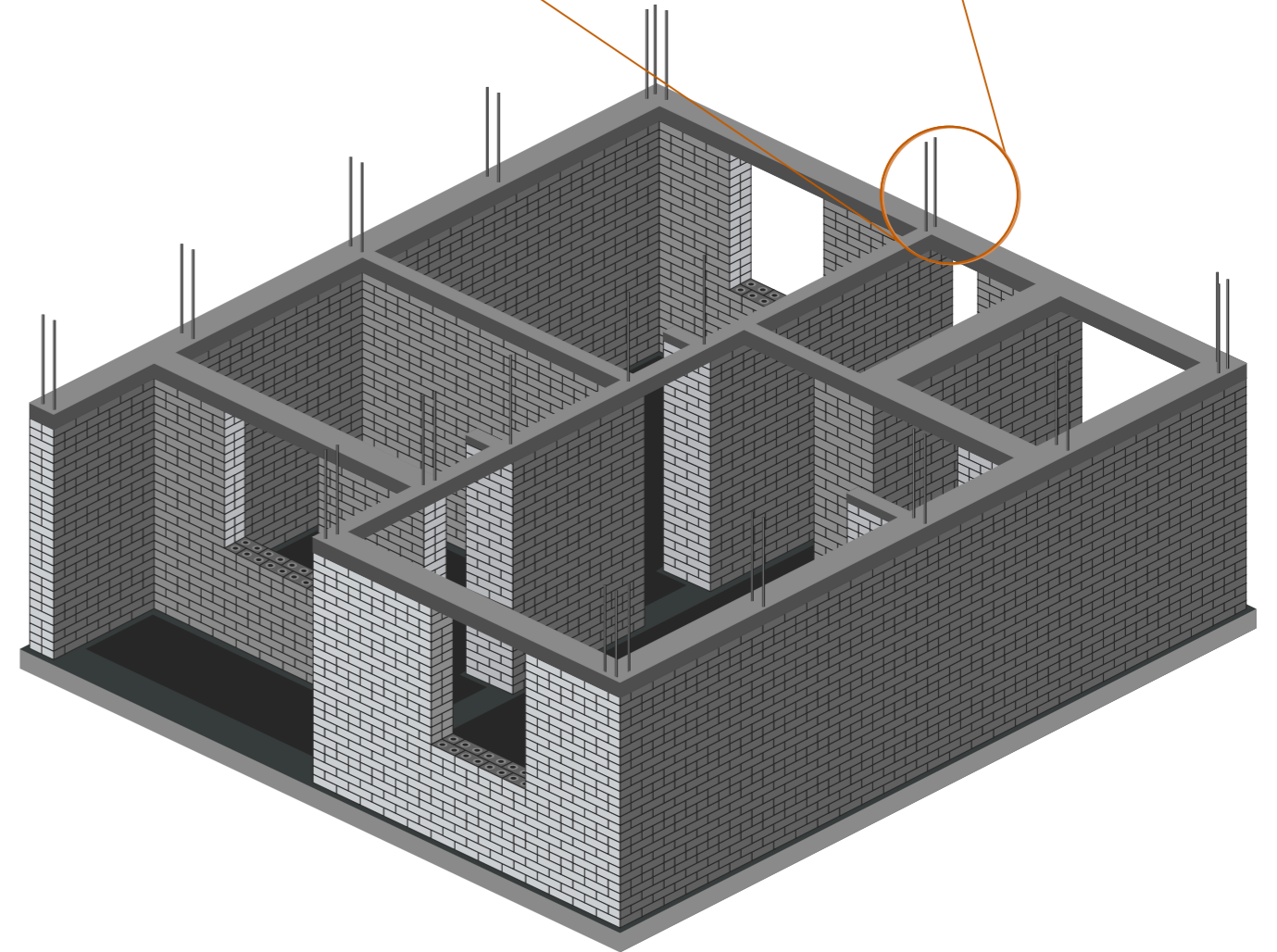
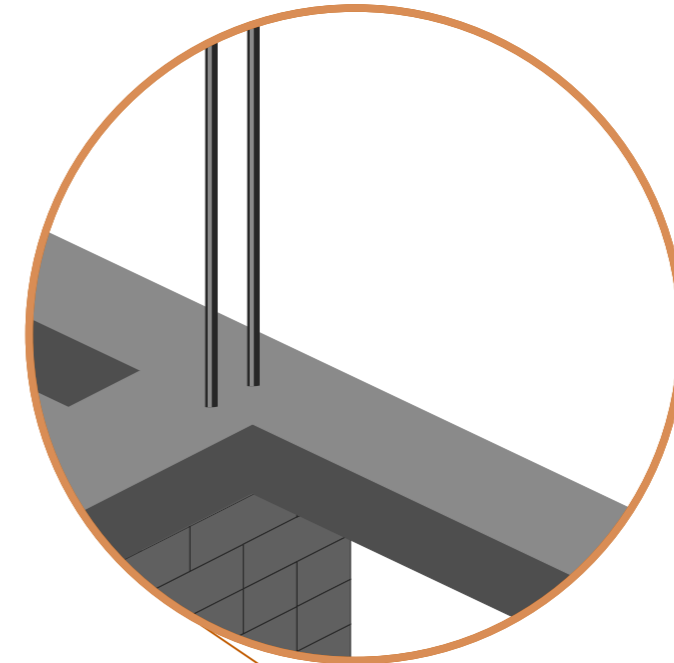

# HLT hilotec

Self-building Manual  
for Sustainable Housing



University of Minho  
School of Engineering



info: [www.civil.uminho.pt/hilotec](http://www.civil.uminho.pt/hilotec)

# HLT hilotec

Self-building Manual  
for Sustainable Housing

- 1 | Introduction
- 2 | Soil Selection
- 3 | Manufacturing Blocks
- 4 | Construction of Foundations
- 5 | Building Walls
- 6 | Construction of the Roof
  - 6.2 | Objectives
  - 6.2 | Materials and Tools
  - 6.3 | Placement of Purlins
  - 6.3 | Construct Wedges
  - 6.4 | Placing the Purlins
  - 6.5 | Roof Structure
  - 6.6 | Roof Cover



University of Minho  
School of Engineering

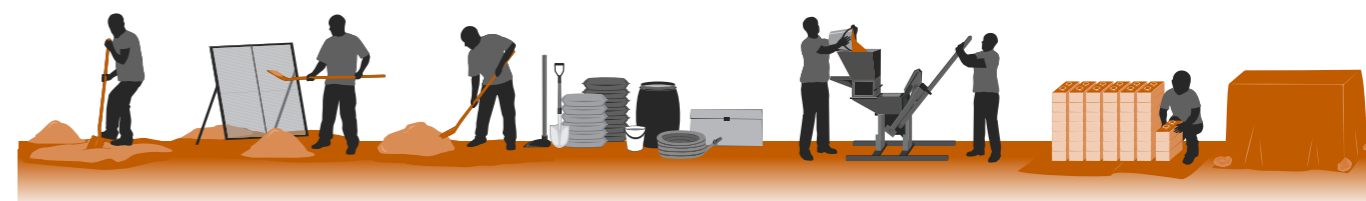

**Objectives**

In this Chapter you will learn how to build the roof of your house!

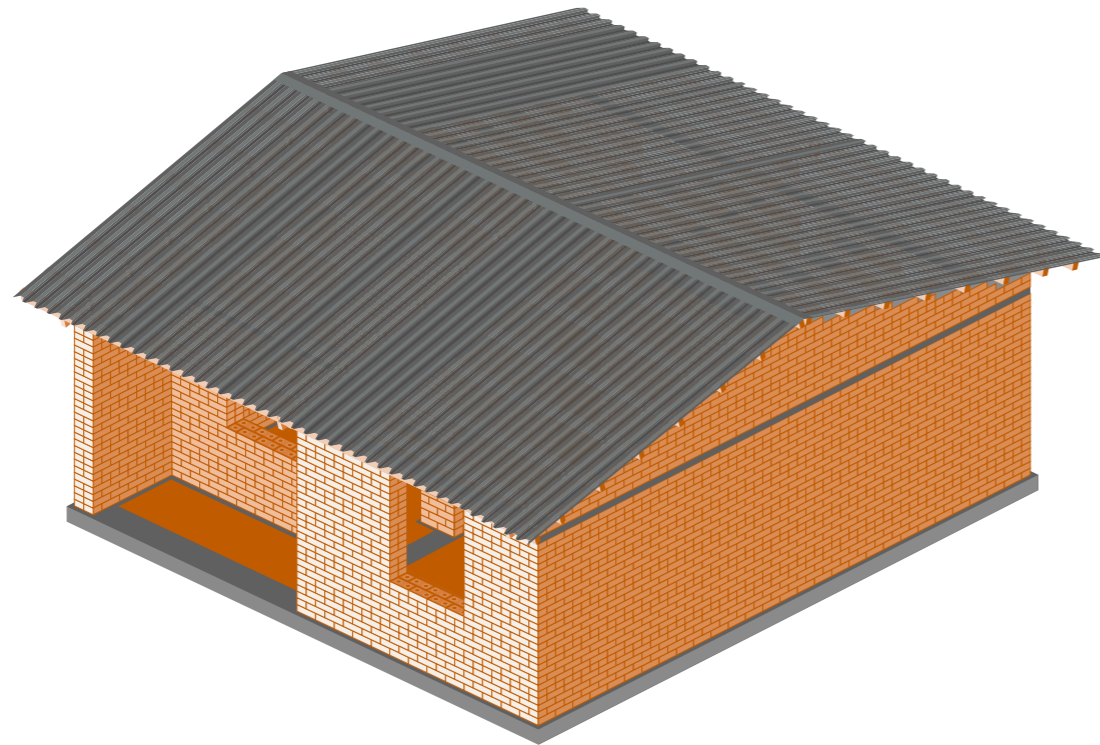

**Materials and Tools**

These are the materials and tools that you will need in this phase: **wood, galvanized metal sheets, roll top ridge, roofing nails and nails.**

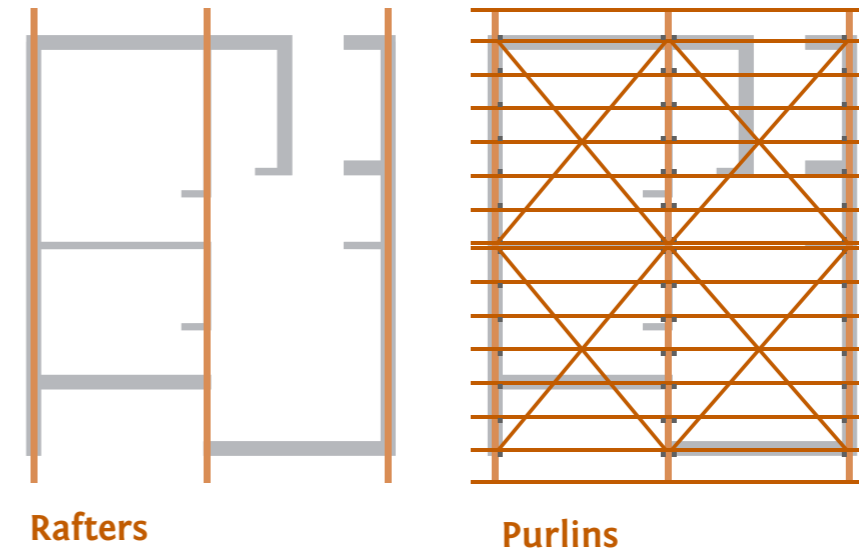
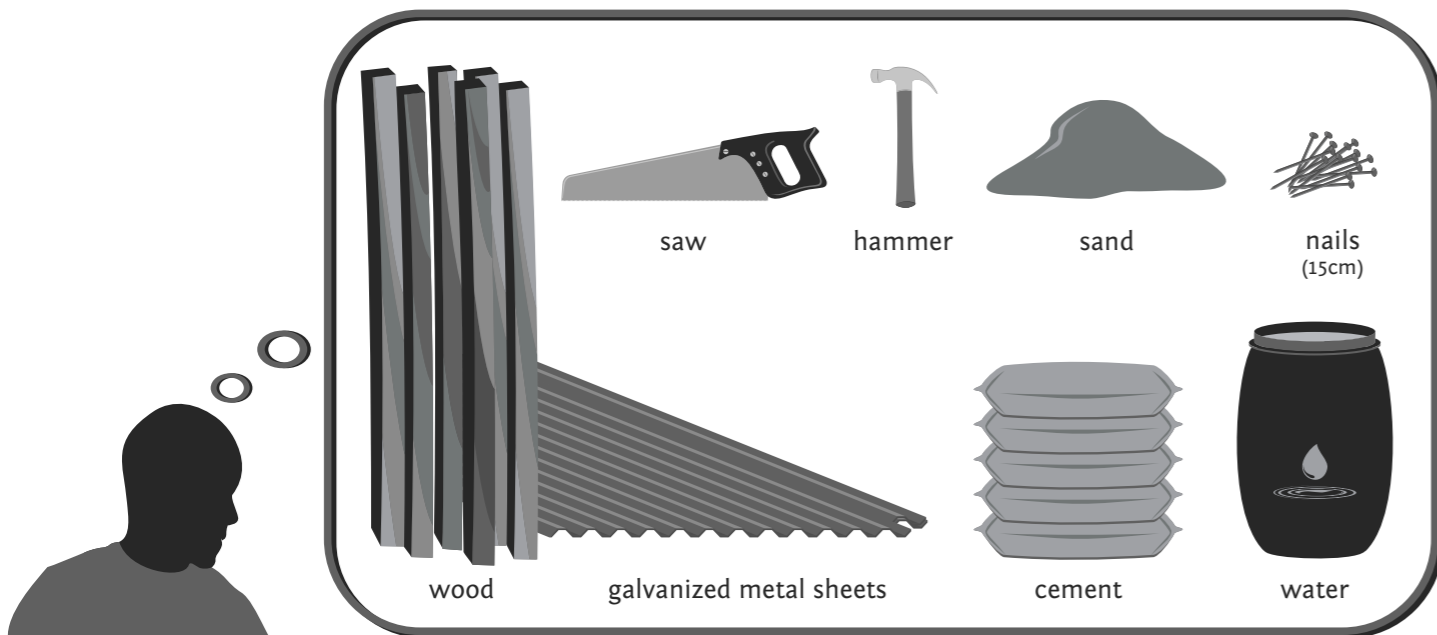

**Placement of Rafters and Purlins**

- 1 Level the last row with cement mortar, to obtain an inclined plane.
- 2 Make inclined 10mm holes into the rafters in those places where the steel bars will pass.
- 3 Once the rafters are put in place, the steel bars are bent to form a hook.
- 4 Finally, place the purlins in a perpendicular direction to the rafters.

**Detail of Connection**

The connection of the purlins to the rafters are made with nails.

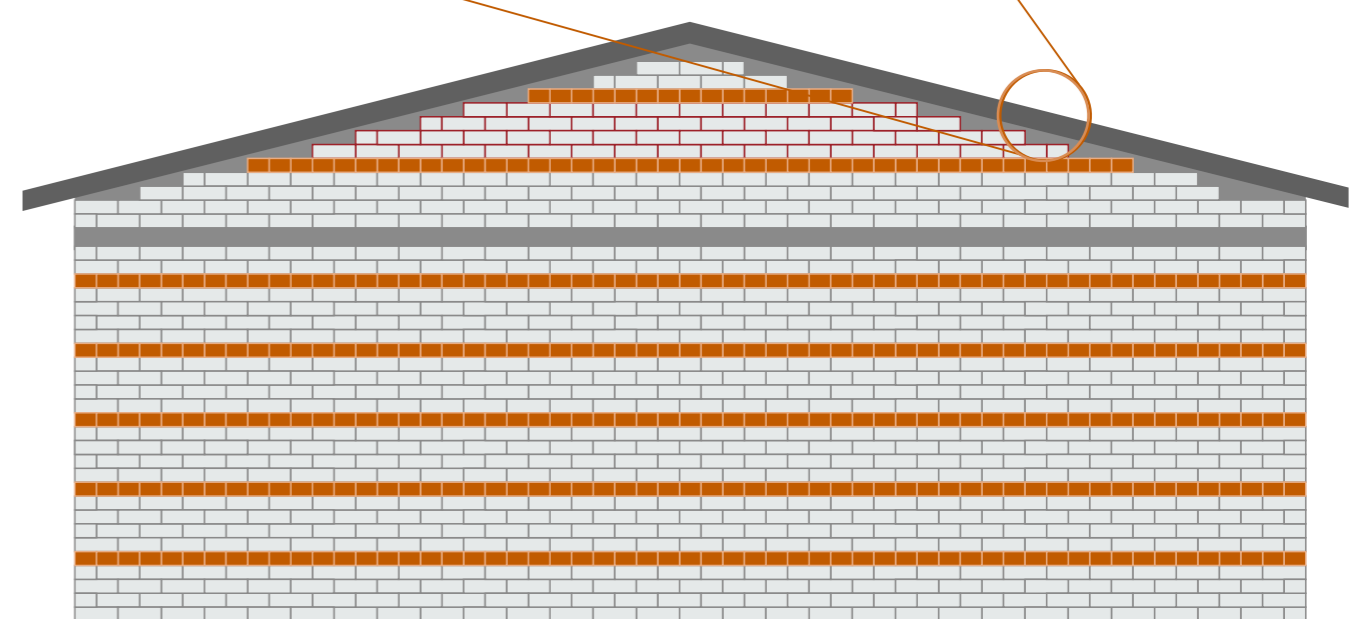
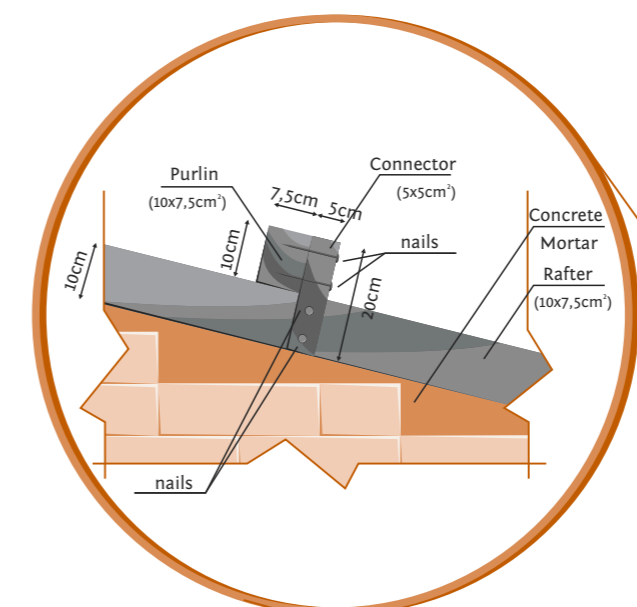



Placing the Purlins

Place the purlin on the roof. First nail the purlin of the top and bottom to the rafter. Then work your way up. Don't forget to also place the connectors on each side of the rafters.

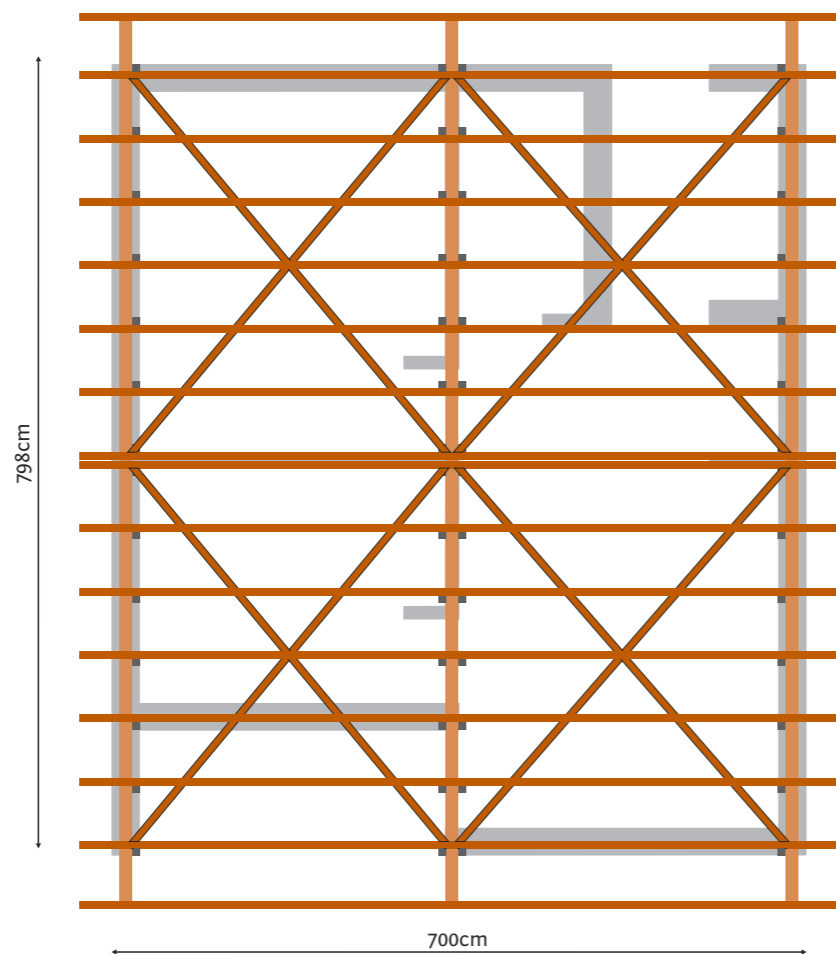
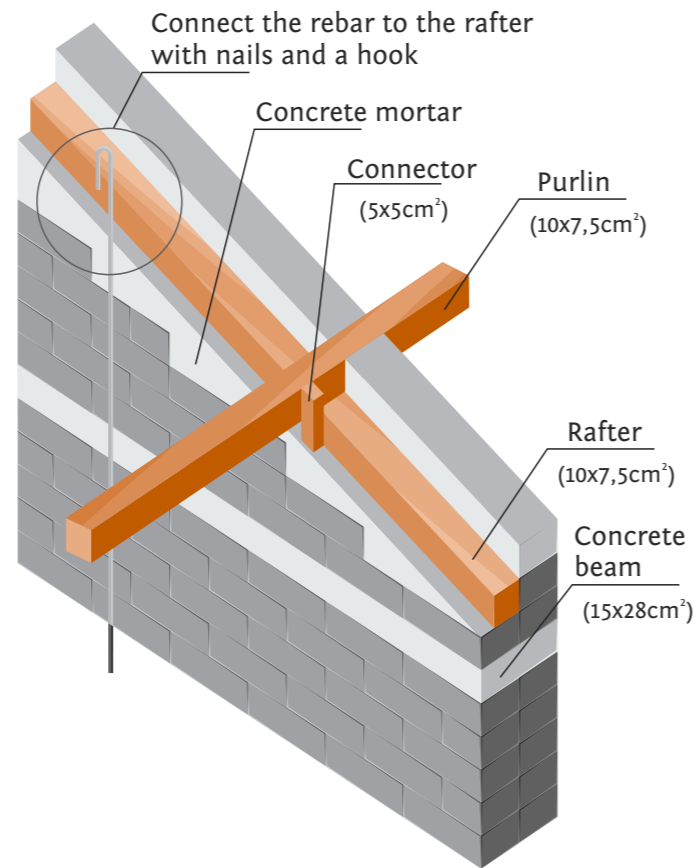

Roof Structure

This is how your house should look like, once your roof structure is finished.

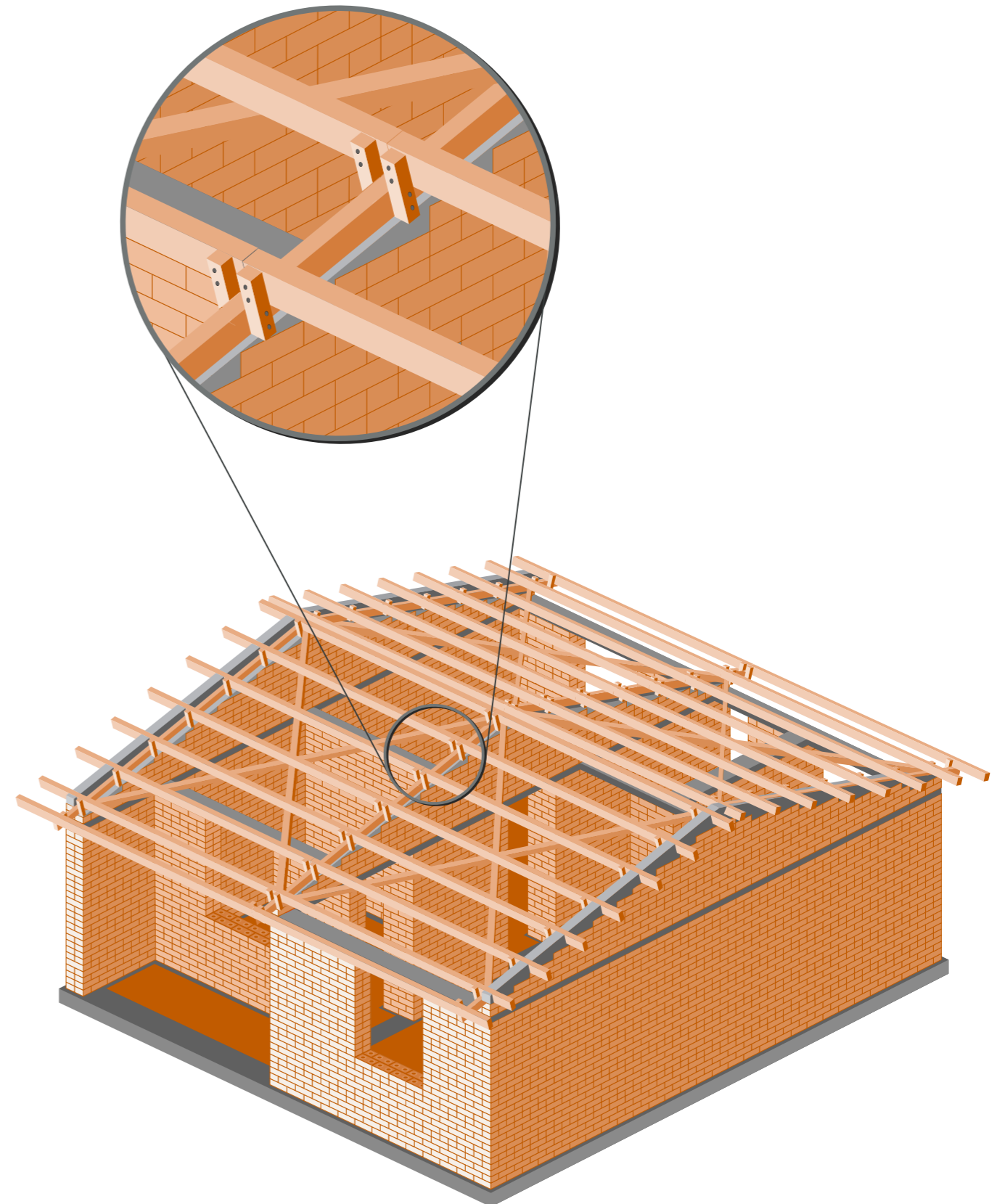

### Roof Cover

Fix the roof sheets to the purlins by placing roofing nails every 50 cm on each purlin. The corrugation of the sheets has to face downwards. Finally, lay down the roll top ridge and nail both overlapping sheets simultaneously.

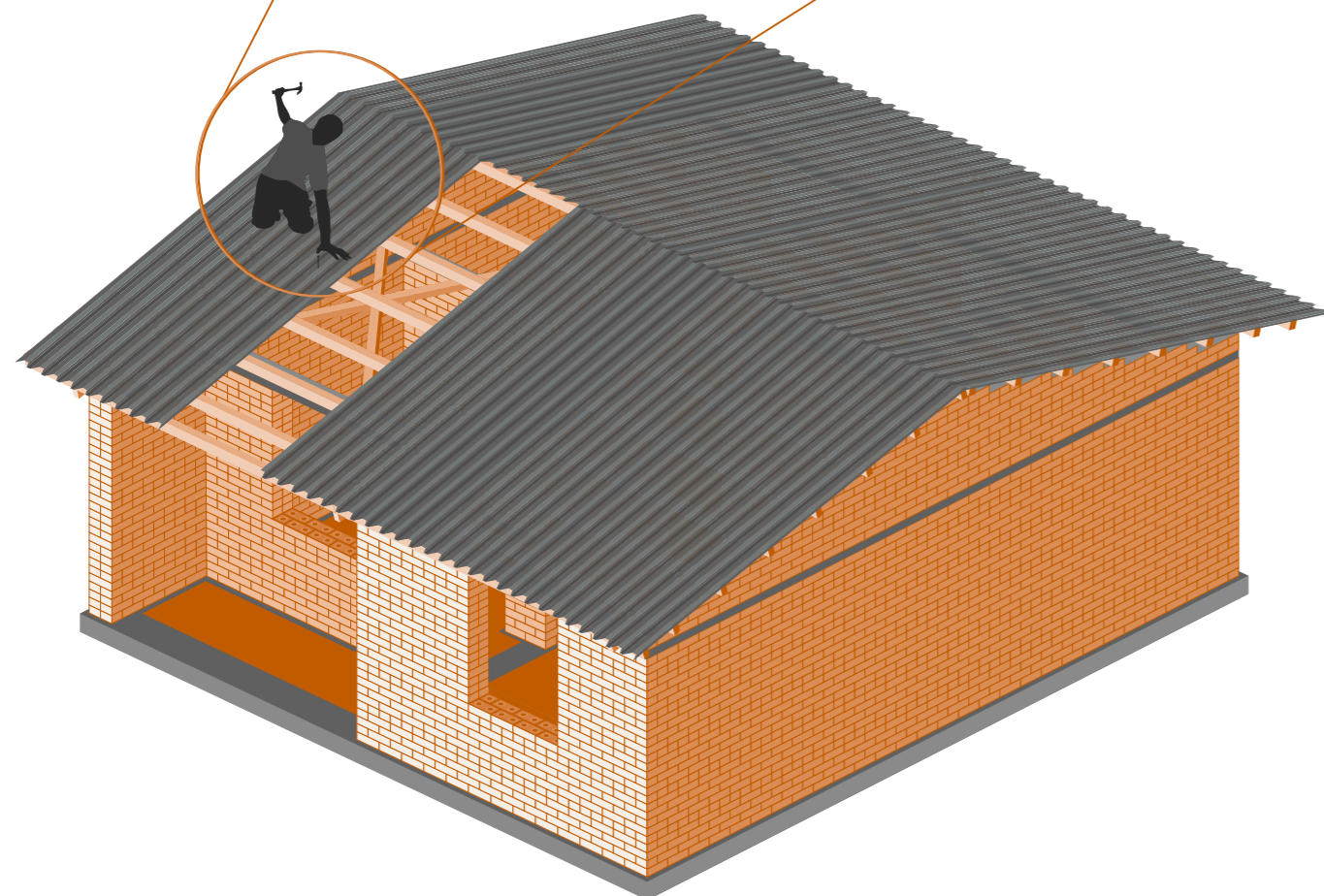

### Roof Cover

Congratulations, the house structure is finished. This is how your house should look before putting in the doors and windows!

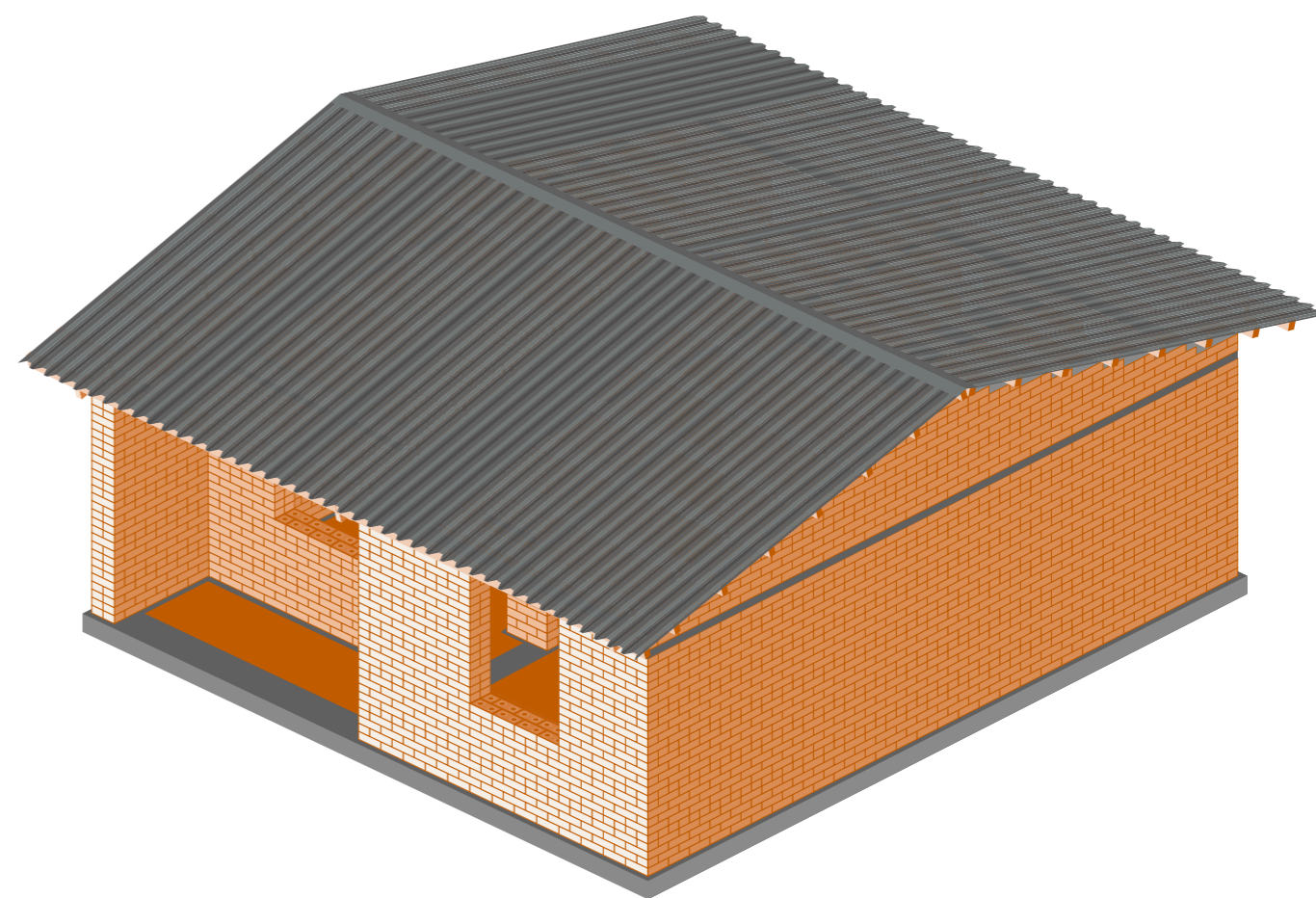



**Mota-Engil Group** is engaged in a wide range of activities related to Engineering and Construction, the Environment and Services, Concessions of Transport Infrastructures and Mining. Mota-Engil's commitment to quality and the established goals, its growing presence on the international scene, and the diversity of services guaranteed through the technical skill demonstrated on each project have enabled the Group to build and maintain a reputation for excellence in each market where it is working all over the world.



The purpose of the Portuguese **Manuel António da Mota Foundation** is to promote, develop and support initiatives with social nature in the fields of welfare and social responsibility, as well as initiatives of cultural nature in the fields of education, health, environment, organization and support of artistic activities. The Foundation acts in Portugal and in all countries where the Mota-Engil Group has established economic actions. Furthermore, the foundation established the annual "Prize Manuel António da Mota", which is one of the most distinguish Portuguese prizes in the field of social responsibility. With the HiLoTec self-construction manual, the Foundation aims to increase the interaction with developing countries, as well as with ONGs all around the world.

 **hilotec**  
Self-building Manual  
for Sustainable Housing



University of Minho  
School of Engineering



Institute for Sustainability  
and Innovation  
in Structural Engineering



Centre of Territory  
Environment and Construction



info: [www.civil.uminho.pt/hilotec](http://www.civil.uminho.pt/hilotec)



## Self-building Manual for Sustainable Housing

### Simple, economical and sustainable earth technology solution to build your own house

This self-building manual for dwelling houses is one of the results of the HiLoTec Project - Development of a Sustainable Self-Construction System for Developing Countries, carried out by University of Minho, Portugal, and Mota-Engil S.A. Construction Group, between 2010 and 2013. The project aim was to develop simple but innovative construction technologies for the sustainable self-construction of small buildings in developing countries, including those with seismic hazard.

The construction technology combines both natural and traditional building materials with more advanced construction techniques. Sustainability and low cost housing were the main objectives for the HiLoTec project. The self-construction manual can be used by rural or urban families with lower incomes in developing countries, which need better houses for living. Therefore, the HiLoTec self-building manual addresses a building system which is economically competitive with current systems and more sustainable from the energy point of view.

University of Minho and Mota-Engil S.A. wishes that this manual will bring to the world a higher living standard for those who will construct the HiLoTec houses, bearing in mind that construction sustainability and the social responsibility will always be part of human kind development.



University of Minho  
School of Engineering



Institute for Sustainability  
and Innovation  
in Structural Engineering



Centre of Territory  
Environment and Construction

