



## Design of an Adapted Standing Frame for Rehabilitation of Children with Mental Deficiency

José Machado

CT2M Research Centre / University of Minho  
4800-058 Guimarães, Portugal  
jmachado@dem.uminho.pt

Eurico Seabra

CT2M Research Centre / University of Minho  
4800-058 Guimarães, Portugal  
eseabra@dem.uminho.pt

### Abstract

A standing frame is a mechanical (old) or mechatronic (new) equipment, that has as main goal to correct the incapacity of certain individuals for assuming the body's vertical position. The existing standing frames, on the market, do not allow easy placement of the patient on the device, do not allow full mobility (within and outside of buildings), they are not versatile, they are not modular and they do not allow children to have occupational activities during treatments. This paper presents the project of a Standing frame for use in the treatment of children with mental deficiency. The Standing frame presented in this paper takes into account the limitations mentioned above and is perfectly adapted to this very specific and very special target people. The main features of the equipment whose project is presented in this article are the modularity, easiness of placing the patient and easiness of use, especially when the patient, and family, need to travel and need to carry with them the standing frame.

### Keywords

Human Rehabilitation; Machine Design; Standing Frame; Biomechanics.

### Introduction

Human rehabilitation is a main concern nowadays and some techniques and tools are being developed for this purpose.

Among different problems related with human rehabilitation, the need of making some people to reach vertical position is a great concern because the behavior of multiple organs of human body depends of capacity for humans being in vertical position, usually related with the use of a standing frame.

The vertical position achieved with a standing frame is recommended by the benefits it brings to the individuals. Standing frames are, in general, expensive and used by people who have a better balance and control of the chest. The standing frames appeared to be reasonable and convenient equipments. With these systems the user can stand passively for a fixed time [1], having as benefits:

- Prevention or reversal of osteoporosis and resultant hypercalciuria [2] - [6].
- Prevention of contractures and improvement in joint range of motion [3], [4], [7], [8].
- Reduction of spasticity [4], [7], [9]
- Improvement in renal function, drainage of the urinary tract, and reduction of urinary calculi [3], [4], [5], [7], [10].
- Prevention of pressure ulcers [3]-[5].
- Improvement in circulation, as it relates to orthostatic hypotension and other benefits of good circulation [10], [5], [7].
- Improvement of bowel function [10].

The corrections of the body's vertical position can be simple or more complex depending on the patient and on his/her lesion. Despite the great technological evolutions applied on these systems, it is strongly necessary to develop a standing frame adapted to a specific and important group of persons that are really sensible to these treatments: the children with mental deficiency.

This group of population has some specific needs that are not taken into account with "standard" standing frames. Among other special needs, of this group of population, some of the most important are:

- In case of children, it will always need assistance to achieve their positioning in the device;
- The variation between the seated and standing positions and vice versa requires assistance from another person;



- The equipment is usually large, so its weight is also quite high and difficult to carry indoors;
- Limit level of activities of occupational therapy that could be developed.
- ...

This paper presents the project of a Standing frame for use in the treatment of children with mental deficiency. The Standing frame presented in this paper takes into account the limitations mentioned above and is perfectly adapted to this very specific and very special target people. The main features of the equipment, whose design is presented in this article, are the modularity, easiness of placing the patient and easiness of use, especially when the patient, and family, need to travel and need to carry with them the standing frame.

In order to achieve the proposed goals, the paper is organized as follows: this section was devoted to presenting the context of this work; next section will be devoted to the study of existing standing frames; further, there will be presented some points that must be improved, in order to obtain a standing frame adapted to children with mental deficiency; further, some found solutions are presented and, finally some conclusions and ideas about future work are presented.

### Existing standing frames

The standing frames can be grouped in three distinct groups: *prone*, *supine*, and *vertical*. Each group has advantages and disadvantages and it is possible, too - that for a specific need of one patient - more than one group could present an adequate solution. Concerning detailed characteristics of each group, the description is the following:

- *Prone Stander*: supports the front of the body and is used for people with a good control of the head, allowing weight bearing through the arms. This type promotes the use of the extensor muscles to stay upright, and thus promote the raising of the head. It allows the user to tilt forward by the variation of the angle that ensures its standing position. The supports can be adjusted according to growing or according the change of physical condition of the user. Some *prone* standers are designed like this because slope is made against a board. Typically, they present a more stable basis which allows the displacement of the device anywhere and can even make small structures that allow, more easily, the indoors movement. This kind of standing frames allows both adults and children, develop their skills while remaining standing up and holding on the same position for a longer period of time. The fact that the user is skewed enables him to use the space for work or play, encouraging the use of both hands. In general, they are supported with ties or belts, especially for the chest and knees. For children with mild or moderate neuromuscular limitations, an adaptive *prone* stander can be a great help. Its aim is to help children adjust to gradually move the weight of their body as well as the movement of the device [11] [12].

- *Supine Stander*: supports the user along the posterior region and has several adaptations that facilitate the improvement of their capabilities; also they contain lateral supports, which maintain the symmetry of the body, as well as belts and pillows to allow position of feet, knees and trunk. Most of such devices have trays or tables, providing a space for working or playing, for children users. It is, also, important for individuals that do not have the ability to remain fully upright. There are three types of representative *supine* standers, as follows:

- *Large Supine Board*: it is characterized by being a device recommended for children and adults with heights between 46 and 72 inches (1.10 m to 1.80 m). It was designed to support the body of the user in a position other than the optimum. It offers greater autonomy and control over the head, torso, pelvis, knees and feet providing better weight distribution. It is ideal for circumstances where the control capacities of head and shoulders have not been lost.

- *Mini-Supine Stander*: standing frame that has a board designed according to the needs of children in cases of previous interventions programs. It is equipped with an adjustable angle tray, adjustable belts for trunk and knees, ties for the pelvis, knees and chest among others.

- *Upright Standing Frame*: equipped with a platform, built mostly of wood and metal parts, with support pillows, armrests and allows easy movement [11] [12].

- *Vertical Stander*: it is used to obtain maximum weight bearing through the body and it is recommended for people who have a good balance and control over the trunk, because they provide less support than a *prone* or *supine* standers. These standing frames ensure a stabilization of three points when uprighting users, having support for knees, hips and torso, and being recommended for children with postural insecurity. [11] [12].

In conclusion, the *supine* stander is used to introduce the ability to support weight when no longer exists control of the head. The *prone* stander is used when there is a minimum check of the head, allowing stimulation



of the trunk and extensor muscles of the lower extremity, as well, it provides a position considered functional for the upper extremity. The *vertical* stander keeps the child in a desired upright position where the maximum weight, supported by legs in vertical direction, is achieved.

### Points that must be improved on standing frames

After the study of existing standing frames, the idea is to select the most complete (following some criteria exposed in this chapter) and then to improve the selected standing frame with design of new parts and suggestions of improvement.

The ideal standing frame is the one that can conciliate the largest number of advantages, that is - through an assessment of the market and after consideration of the best existing devices - the collection of characteristics that make them "the best". These characteristics/properties are exposed in this paper and they are "weighted" in order to be combined in one single device.

#### • Ideal properties of a standing frame

In order to obtain a best design for a standing frame, it was necessary to quantify some ideal properties/characteristics of this device. At least twenty-one characteristics have been identified and are presented in this sub-section.

The evaluation of each one of the characteristics, considered as ideal, is based on the following scale:

- 1 point - Dispensable;
- 2 points - Optional;
- 3 points - Necessary;
- 4 points - Essential;
- 5 points - Mandatory.

The characteristics considered for evaluation are:

- C1 - *Changing/Flexibility of the size of the structure of the standing frame*: 5 points – As children have a fast development and bone growth it is crucial that standing frame allows flexibility concerning human high;
- C2 - *Flexibility of the inclination angle (several positions: leaning forward (prone), tilted back (supine) and lying*: 4 points – Once the child is in the "stand up" position, it is an added value of the device to allow different inclinations. Thus, it is possible to perform numerous activities decreasing the monotony associated with a single position.
- C3 - *Safe changing of position (from vertical position to sitting position and from sitting position to vertical position)*: 5 points – this characteristic is mandatory when referring to a standing frame, since this is its main function;
- C4 - *Ability to perform movements (passage from one position to another) without requiring assistance of another person*: 2 points – as this device will be used by children with special medical conditions that require constant monitoring, this feature becomes optional because only children with mobility can use this mechanism;
- C5 - *Easy to use and easy to carry*: 3 points – it must be easy to use and carry to other locations thus providing social interaction and leisure activities;
- C6 - *Easy transfer of a wheelchair to the standing frame*: 2 points – it is assumed that all children using the standing frame are also users of wheelchairs and therefore should be promoted the passage from one device to another with minimal effort.
- C7 - *Compact and easy to store*: 2 points – the mechanism should occupy as little space as possible, hence the ability to dismantle and remove some components makes it more compact and easy to store;
- C8 - *To allow occupational therapy devices*: 5 points – it is ideal that the development of muscle control, posture, balance and strengthening of muscles must be promoted, either by placement of devices used in occupational therapy, either by setting the proper equipment to allow this continuous improvement;
- C9 - *Possible to apply to a wide variety of children with motor disabilities*: 5 points – the device should adapt to the conditions imposed by the user, from the simpler pathology till the most complex pathology;
- C10 - *High level of comfort and safety*: 5 points – it must reduce internal and external rotations that can lead to imbalances, and it must ensure maximum possible comfort and stability;
- C11 - *Removable tray, or table, and capable of taking various inclinations according to the position of the standing frame*: 3 points – it must allow different positions for the tray, or table, to be possible that the children have occupational therapy at different inclinations of the user;



3<sup>rd</sup> International Conference on Innovations, Recent Trends  
and Challenges in Mechatronics, Mechanical Engineering  
and New High-Tech Products Development  
**MECAHITECH'11**  
**International Conference**  
Bucharest, 22-23 September 2011



- C12 - *Autonomous adjustment of all system components*: 5 points – To ensure the stability of the child in the equipment, it is mandatory the existence of adjustments allowing the efficient attachment of the child;
- C13 - *Removable support devices for head and chest, including lateral supports*: 2 points– it depends on the disease of the user;
- C14 - *Cushioned supports for head, torso, pelvis and knees*: 5 points –fasteners being cushioned are essential for comfort and well being of the user;
- C15 - *Washable*: 3 points – it arises from the need to eliminate all kinds of dirt that may be accumulated on the system components during use;
- C16 - *Adjustable strap, moved by electrical power, to raise the pelvis*: 4 points – to be applied at users with low mobility on inferior members, allowing safe transfer from wheelchair to the standing frame;
- C17 - *Large basis*: 5 points – it is mandatory to maintain the stability of the system and the stability of the user in any position at any angle;
- C18 - *Wheels in a material that don't make marks on the floor (front wheels must be directional and back wheels don't need to be directional) with fast breaking system*: 4 points – Despite promoting occupational therapy to facilitate maneuvering, also allows the movement to several places, decreasing the monotony of having a single location for treatments;
- C19 - *Low weight*: 3 points – The standing frame should be as light as possible, thus facilitating, simultaneously, its transport and movement by users;
- C20 - *Fun colors and fun shapes*: 4 points – As the device is intended for children it is essential the use of appealing colors and appealing shapes, “encouraging” their use;
- C21 - *Duration of the equipment*: 5 points – the equipment will be adapted at changing of body dimensions, so it must have a long duration;

- **Evaluation and selection process**

After an attempt to quantify the characteristics of standing frames, that are most important for direct application in the development of a standing frame for children with mental deficiency, it was done an analysis of various equipments and it was selected one of them to be used as a working basis of our project. The models of standing frames were selected based on the realization of a market analysis which allowed the assessment on the use of them, i.e. those covering a larger number of diseases and a larger number of users, considering also the most modern equipments. To this end, we considered a total of 20 types of standing frames and selected 12 that best corresponded to the needs and intended purposes. The considered devices were: *Nexus, Model C4618, Prone Stander, Humphrey, Horizon Stander-Leckey, Camel, Charly-Medial-Plus, Primary School Prone Standing frame, Infants/School Prone Standing frame, Supine Stander, Infants Supine Standing frame and Youth/Adult Prone Standing frame.*

From the realization of a *table of value* it was possible to identify the most capable with the identification of its strengths and weaknesses. The final classification of each model was obtained by the weighted sum of the values from 1 to 5 assigned to each characteristic/property. These values were assigned based on a critical analysis of the information contained in catalogs of standing frames.

From the analysis of the *table of value*, we verified that, according to the evaluation criteria, it should be selected the most appropriate model that corresponds to the greatest number of characteristics. This equipment is: *Charly – Medical Plus* [13] presented in figure 1.



Figure 1: Standing frame *Charly – Medical Plus* [13]

- **Targets for improvement**

After selecting a standing frame that is the working basis, the next step is to define some aspects to improve, in this standing frame, taking into account that the main goal is to design a standing frame adapted to children with mental deficiency.

The targets for improving structural and mechanical properties were established according to the analysis of the *table of value*. Table 1 presents limitations and possible solutions to eliminate/reduce those limitations of this standing frame.

Table 1. Targets and proposals for improvements

<b>Targets</b>	<b>Proposals for improvements</b>
1. Safe changing of position (from vertical position to sitting position and from sitting position to vertical position).	To develop a mechanism to promote this goal: to define it and to represent it.
2. Ability to perform movements (passage from one position to another) without requiring assistance of another person.	Automatic and manual control systems and control devices.
3. Easy to use and easy to carry.	New design of the structure, selection of new materials and manual and/or automatic action to allow its operation.
4. Easy transfer of a wheelchair to the standing frame.	Design of a removable support system for arms.
5. Compact and easy to store.	Definition of the mechanisms that allow the movement of system components.
6. Removable support devices for head and chest, including lateral supports.	Selecting the best material and the best mechanism to move the parts of the standing frame.
7. Washable.	Definition of all materials used for the manufacture of supports and cushioned supports.
8. Adjustable strap, moved by electrical power, to raise the pelvis.	Design of the strap, explaining how, and when, it will be used.
9. Low weight	Listing of all materials used in the production of equipment and evaluation of their properties.
10. Fun colors and fun shapes.	Changing the image of the cushioned supports and to propose objects that can be added to the devices making it more attractive without neglecting the therapeutic purposes.
11. Duration of the equipment.	Good quality materials with appropriated thermal and/or chemical treatments.

### Possible solutions

The standing frames available in the market make possible to keep the patient's body in vertical position, however there are several ways to reach this goal.

In a process of treatment there are necessary specific exercises depending on the pathology of the patient. Therefore, if the device as more varied the features, it will be possible to use it on a greater number of patients.

Currently in the market there are devices that allow direct placement of the patient on upright position, without having any kind of elevation from the position "seated" (verticalization beds). However, standing frames, which start the process of elevation in the "seated" position, are very necessary because due to lack of mobility of patients, this feature becomes an advantage in the daily life of users.

The lack of variety of inclinations in this type standing frame (basis of our work) is a disadvantage that must be addressed. Thus, using advanced software engineering, it has been designed a standing frame that meets both the elevation of the patient from the position "seated" or the possibility of new inclinations before the vertical position (90° with floor) that is not allowed, now, by the standing frame of figure 1. Thus, to overcome these limitations, the main components of the standing frame were designed: equipment basis, the pads, the tray, or table, and the cushioned supports for feet, knees, chest and head.

- **Basis of equipment**

The basis of the equipment has the function of supporting the entire structure and is the larger component of the standing. So, we tried to reduce its size without compromising the resistance presented compared with different equipments on the market.

The main advantage of decreasing the size of this structure is to enable better storage of the device when not in use, and also facilitate its transport. In figure 2 it is illustrated the standing frame in the storing position and also on the working position.

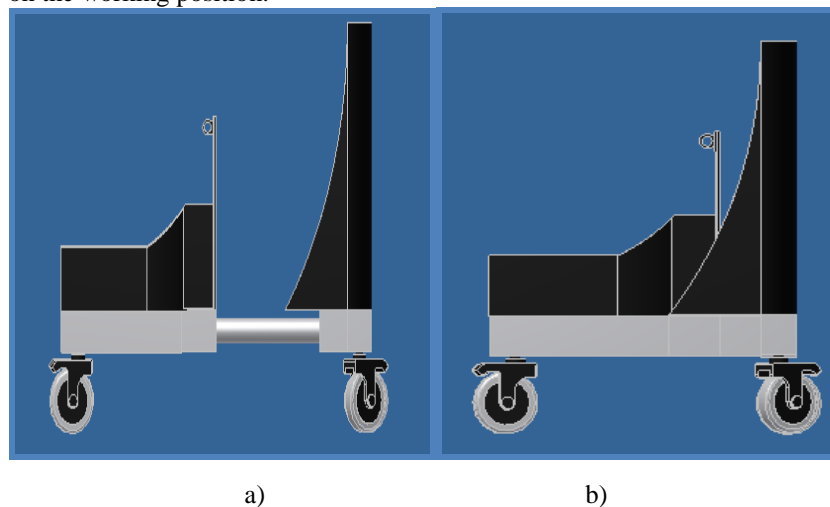

Figure 2: Basis of the standing frame: a) working position; b) storing position

- **Articulated structure, for pads and feet support, hydraulically actuated**

As it can be stated in figure 3, the support metallic structure for pads is composed by two main area: an area on the patient's buttocks and another for the patient's backs. Those are linked to the support structure of the feet. Figure 3 allows to check the forms assigned to these sections of the equipment, and to observe the lifting system performed by a hydraulic cylinder.

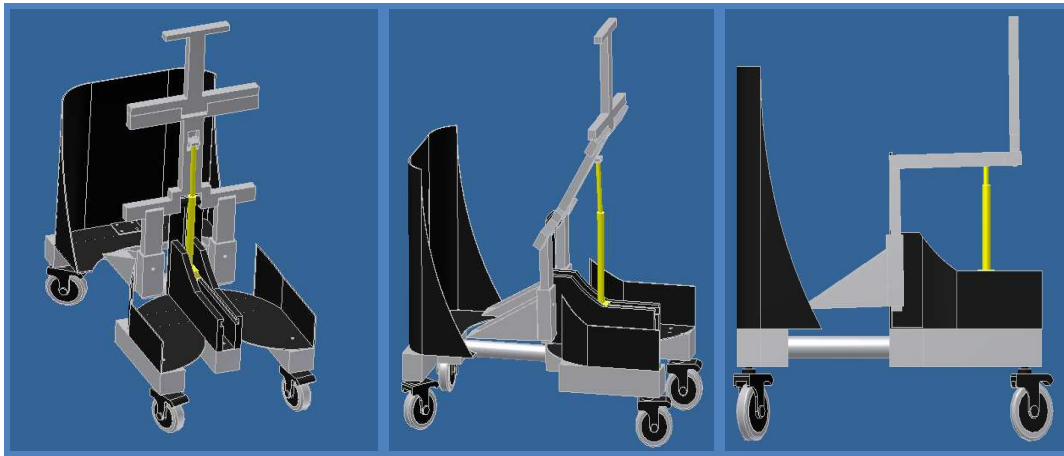

Figure 3: Support metallic structure without pads

It is important to note that with this configuration it is possible that the feet support accompanies the user's movement, that is when the user is on vertical position ( $90^\circ$  with the ground) or at supine position (supported by the rear of the body).

Concerning the mechanisms that regulate the movement of these components it was decided that the joint that connects the support of feet to other structures is a rotational joint fixed to the basis / support of the standing frame, and, around this, it is possible to rotate and adjust either the supports of feet as well as the lifting of the support structure of the pads. The limits of rotation associated with the bars of the structure are visible in the figure 4.

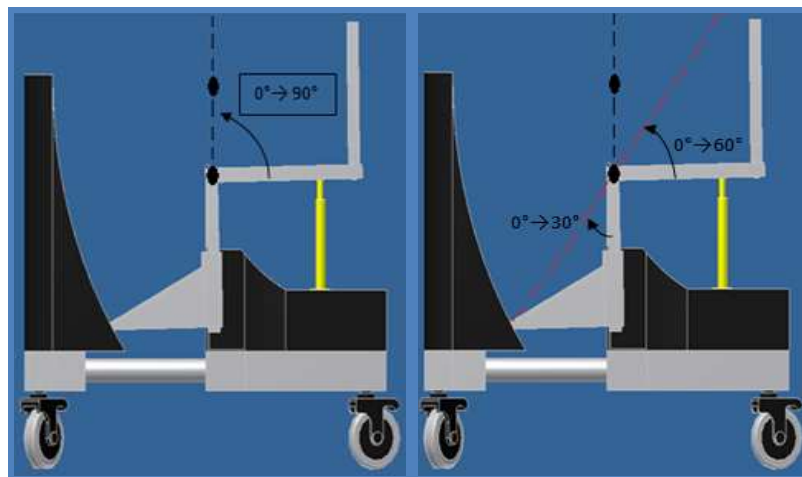

Figure 4: Trajectories and maximum amplitude angles for moving the bars of the structure

For the verticalization system of the standing frame, it was considered a hydraulic system with manual actuation. This way it is used a lever (manual actuation system, in figure 5) that has two functions: to apply force in hydraulic pump and command the directional control valve that allows movement in both directions. Once the lever only allows an angular displacement, total (maximum)  $90^\circ$ , then scroll back and forth, in relation to the stationary position, will be  $45^\circ$ . For the movement of the device, whenever it is wished an upward shift, it is necessary to move the lever forward, allowing the flow (oil) increasing in area 1 (input) and decrease in the area 2 (output) – All of this is controlled by a valve of 3 positions and of 4 ways (Figure 5a). Analog reasoning must be developed for understanding the descending movement of the entire lifting system. However, in this case, it is necessary to move the lever back, and the flow will enter to the area 2 and will go out, due to the compression piston, of area 1 (Figure 5b). Where is intended a situation of the steady state/stop, lever is upright and there is

no transfer of flow (Figure 5c) because the valve closes the connection zone, maintaining a fixed volume of oil in both chambers of the cylinder.

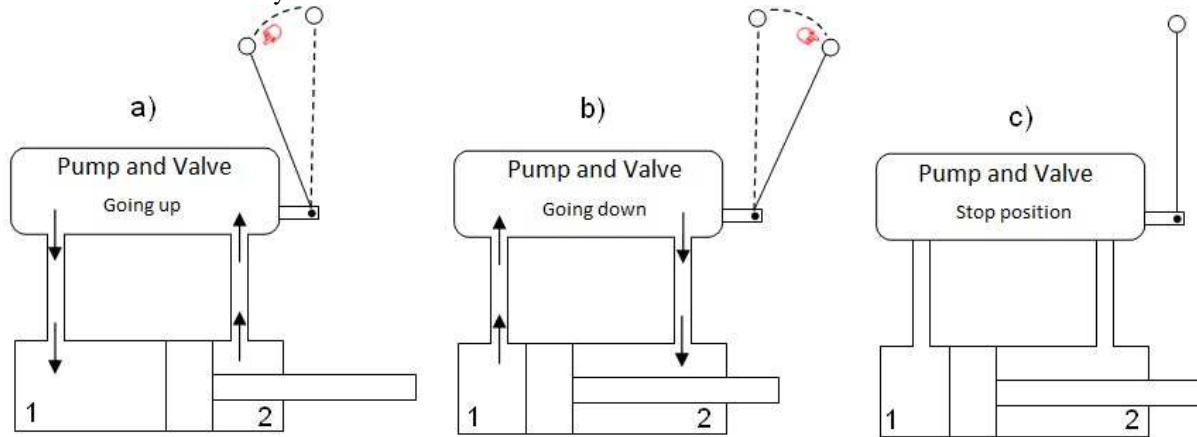

Figure 5: Lifting system of the standing frame actuated hydraulically with manual command of a lever (adapted from [14])

• **Final Solution**

Figure 6 illustrates the final results obtained concerning the design of the standing frame. All the parts are showed in perspective, in the figure.

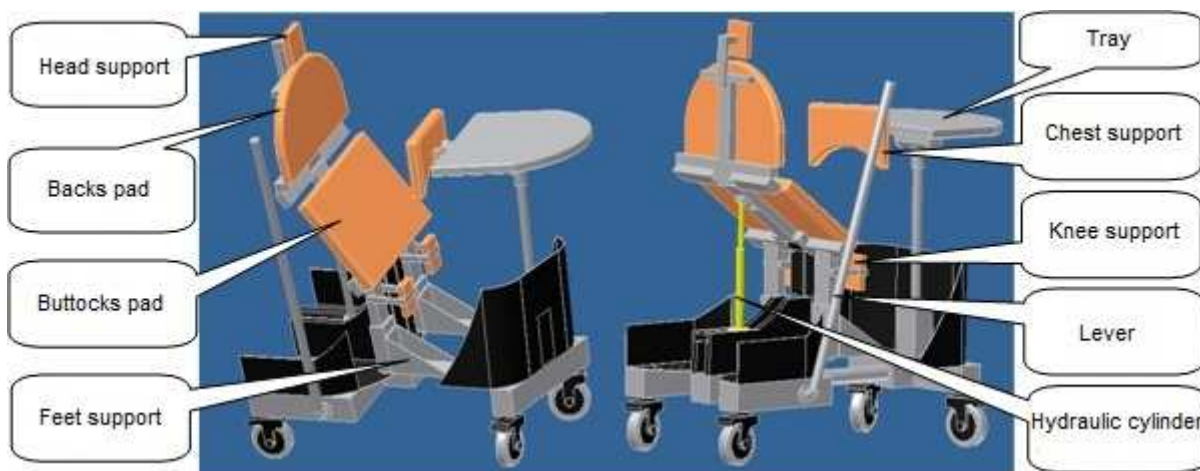

Figure 6: Global illustration of the developed standing frame

**Conclusions and future work**

The completion of this work allowed us to establish, organize and list the steps of design of a mechatronic system that precede placing the device on the market, more specifically, a device such as a medical rehabilitation standing frame. Since market assessment, materials analysis, design simulation, among others, various aspects were considered in order to meet the proposed target, which was mostly achieved.

For the calculations concerning all the parts of this new equipment, with the compilation of the best features existing on the market, it was possible to create a device whose main advantages are to allow vertical integration of the patient from the seated position and, in addition, also be capable of regulating the device to other inclinations, namely the supine position (body supported by the rear). This is of great importance. Standing frames, on the market starting from the position "seated" do not allow other than the full vertical inclination. Another important aspect is achieved by the possibility of reducing the area of the equipment basis/support, for its easier handling and transportation.





3<sup>rd</sup> International Conference on Innovations, Recent Trends  
and Challenges in Mechatronics, Mechanical Engineering  
and New High-Tech Products Development  
**MECAHITECH'11**  
**International Conference**  
*Bucharest, 22-23 September 2011*



As future work we intend to do, first, the detailed design of the solution, namely, the proper and careful selection of off-the-shelf components, the preparation of technical drawings of the components to produce and selection of materials to be used. After this step being completed it will start the phase of the physical construction of the first prototype and then the validation of the prototype with real tests involving children with mental deficiency. The testes will be done with the technical support of specialist doctors, physiotherapists and occupational therapists.

During the next step of detailed design, we will devote our time, also, on studying possibilities of developing systems for occupational therapy. In this project - due to development of occupational therapy systems to apply on the standing frame – there are involved, also, psychologists from a Portuguese Institution (APPACDM of Braga) that works with children with mental deficiencies and it is very interested in this Project. The tests, involving children with mental deficiency, to validate the prototype will be performed in this institution.

### **Bibliography**

- [1] <http://www.lifstand-usa.com/index.asp?a=1&art=2>. Accessed on June 2011.
- [2] Issekutz, B., Blizzard, N.C., Rodahl, K.: "Effect of Prolonged Bed Rest on Urinary Calcium Output". *J Applied Physiology* 21:1013-1020, 1966.
- [3] Cybulski, G.R., Jaeger, R.J.: "Standing Performance of Persons with Paraplegia". *Arch Phys Med Rehab.* 67:103-108, 1986.
- [4] Duffus, A., Wood, J.: "Standing and Walking for the T6". *Paraplegic, Physiotherapy* 69:45-46 (1983).
- [5] Macheck, O., and Cohen, F.: "A New Standing Table". *American Journal of Occupational Therapy.* 4:158-159, 1955.
- [6] Kaplan, P.E., Roden, W., Gilbert, E., Richards, L., and Goldschmidt, J.W. "Reduction of Hypercalciuria in Tetraplegia after Weight Bearing and Strengthening Exercises". *Paraplegia* 19:289-293, 1981.
- [7] Bromley, I. "Tetraplegia and Paraplegia". Churchill Livingstone, pp 145,1985.
- [8] Manley, M., and Gurtowski, J. "The Vertical Wheeler: A Device for Ambulation in Cerebral Palsy". *Arch Phys Med Rehab* 66:717-720, 1985.
- [9] Little, J.W., and Merritt, J.L. "Spasticity and Associated Abnormalities of Muscle Tone". In *Rehabilitation Medicine* (Ed. DeLisa J.) J.B. Lippincott, pp 441,1988.
- [10] Seymore, R.J., Knapp, C.F. Anderson, T.R., and Kearney, J.T. "Use of the OrianSwival Walker: Case Report". *Arch Phys Med Rehab* 63:490-494, 1982.
- [11] Rifton - Standing Aids. Available at <http://www.rifton.com/resources/articles/fieldissues/standingaids.html>. Accessed on August, 2011.
- [12] Abledata - Fact Sheet on Standing Aids. Available at [http://www.abledata.com/abledata\\_docs/standaid.htm](http://www.abledata.com/abledata_docs/standaid.htm). Accessed on July, 2011.
- [13] Medicalplus, (n.d.). Catalog of Charly model. Available at <http://www.medicalplus-pt.com/conteudo/uploaded/videos/pdfs/Charly.pdf>. Accessed on July, 2011.
- [14] Drapinski, J. (1975). "Hidráulica e Pneumática Industrial e Móvel". Brazil: McGraw-Hill